



CUSHMAN™

OWNER'S GUIDE

HAULER 800XE



642988-B

ISSUED FEBRUARY 2015

REVISED FEBRUARY 2016

WELCOME

Thank you for purchasing this vehicle. Before you drive the vehicle, read this Owner's Guide. This guide contains maintenance and operation information. The illustrations can show items that are optional for your vehicle.

You can do most of the service procedures in this guide with common, automotive hand tools. If necessary, contact your service representative for information about how to service the vehicle as shown in the Periodic Service Schedule.

Repair or replacement parts are available from your E-Z-GO dealer or E-Z-GO Service Parts Department.

When you contact E-Z-GO about service or parts for your vehicle, the information below is needed.

Vehicle Model: _____

PIN, VIN or Serial Number: _____

OWNER'S GUIDE ELECTRIC POWERED VEHICLE

HAULER 800XE

STARTING MODEL YEAR 2015

CALIFORNIA Proposition 65 Warning

WARNING: Engine exhaust, some of its constituents, and certain vehicle components contain or emit chemicals known to the State of California to cause cancer and birth defects or other reproductive harm. In addition, certain fluids contained in vehicles and certain products of component wear contain or emit chemicals known to the State of California to cause cancer and birth defects or other reproductive harm.

Never modify the vehicle in any way that will alter the weight distribution of the vehicle, decrease its stability or increase the speed beyond the factory specifications. Such modifications can cause serious personal injury or death. E-Z-GO Division of Textron Inc. prohibits and disclaims responsibility for any such modifications or any other alteration which would adversely affect the safety of the vehicle.

E-Z-GO Division of Textron Inc. reserves the right to incorporate engineering and design changes to products in this manual, without obligation to include these changes on units sold previously.

The information contained in this manual may be revised periodically by E-Z-GO, and therefore is subject to change without notice.

E-Z-GO DISCLAIMS LIABILITY FOR ERRORS IN THIS MANUAL, and SPECIFICALLY DISCLAIMS LIABILITY FOR INCIDENTAL AND CONSEQUENTIAL DAMAGES resulting from the use of the information and materials in this Manual.

These are the original instructions as defined by 2006/42/EC.

CONTACT US:

E-Z-GO Division of Textron Inc.
1451 Marvin Griffin Road.
Augusta, Georgia, USA 30906-3852

North America:

Technical Assistance & Warranty PHONE: 1-800-774-3946 FAX: 1-800-448-8124

Service Parts PHONE: 1-888-GET-EZGO (1-888-438-3946) FAX: 1-800-752-6175

International:

PHONE: 001-706-798-4311 FAX: 001-706-771-4609

This vehicle was designed and manufactured in the United States of America (USA). The Standards and Specifications listed in the following text originate in the USA unless otherwise indicated.

Use Original Equipment Manufacturer (OEM) approved parts to keep the warranty effective.

If you do not correctly do maintenance on the batteries, you will cancel the warranty. Refer to the MAINTENANCE section for instructions on the correct maintenance of the batteries.

BATTERY PROLONGED STORAGE

The batteries discharge over time. The rate of discharge changes according to the ambient temperature, the age and condition of the batteries.

Completely charged batteries will not freeze in winter temperatures unless the temperature is less than -75°F (-60°C).

For winter storage, the batteries must be clean, completely charged and disconnected from any electrical drain.

The battery charger can stay connected to the vehicle to keep a full charge on the batteries while the charger is connected to an active electrical supply. If the power to the electrical supply is disconnected or interrupted, the battery charger will continuously check the charge on the battery pack. A continuous check of the battery pack will pull power from the battery pack and drain the batteries.

The batteries must be checked and charged again as required or at a minimum of 30-day intervals.

Check and keep correct fluid level in all battery cells during the storage period. Correct fluid level is necessary for maximum battery performance.

BATTERY DISPOSAL

Lead-acid batteries are recyclable. Return discarded batteries to distributor, manufacturer or lead smelter for recycling. For neutralized spills, put residue in acid-resistant containers with absorbent material, sand or earth and discard according to local, state and federal regulations for acid and lead compounds. Contact local or state environmental authorized people for the disposal information.

SAFETY

GENERAL	1
NOTICES, CAUTIONS, WARNINGS AND DANGERS	1
GENERAL OPERATION	3
MAINTENANCE	4
LABELS AND PICTOGRAMS	5

GENERAL SPECIFICATIONS

VEHICLE DIMENSIONS	8
TURNING DIAMETER AND INCLINE INFORMATION	9

INTRODUCTION

FEATURES	11
General Information	11
Key and Light Switch	11
State of Charge Meter	11
Direction Selector	11
Accelerator Pedal	12
Brake and Parking Brake Pedal	12
Horn	12
Turn Signal Switch (if equipped)	12
Front Seat	12
Front Hip Restraint	12
Glove Box Doors (if equipped)	12
Steering Wheel.....	12
Brake Light and Turn Signal Light.....	12
Truck Bed.....	12
Truck Bed Latch	12
Weather Enclosure (if equipped).....	13
DC to DC Converter	13
Charger Receptacle	13
Battery Compartment	13
Run/Tow Switch	14
Hour Meter	14
Sun Top And Windshield (if equipped).....	14

TABLE OF CONTENTS

OPERATING PROCEDURES

SERIAL NUMBER LOCATION	15
BEFORE INITIAL USE.....	15
PORTABLE CHARGER INSTALLATION	16
UNDERSTAND THE CHARGER.....	18
LED Operation Codes	18
LED Fault Codes	19
HOW TO USE THE CHARGER.....	19
CHARGER MAINTENANCE.....	19
HOW TO OPERATE THE VEHICLE	20
Key and Headlight Switch Operation	21
Direction Selector Operation	21
Accelerator Pedal Operation	22
Brake and Parking Brake Operation	22
Horn Operation	22
Run/Tow Switch Operation	22
Truck Bed Operation	23
Truck Bed Latch Operation	24
Tailgate Operation	24
TRUCOURSE TECHNOLOGY SYSTEM™ (TCT)	25
Performance Options	25
How to Change Performance Options	25
General	27
Pedal-Up Braking Feature	27
Walk-Away Feature	28
Anti-Roll Back Feature	28
Anti-Stall Feature	28
High Pedal Disable Feature	28
Diagnostic Mode Feature	28
STARTING AND DRIVING	29
Starting Vehicle On A Hill	29
Terrain	29
Coasting	30

MAINTENANCE

VEHICLE CLEANING AND CARE	31
ENVIRONMENTAL CONCERNS.....	31
Battery Disposal	32
LIFTING THE VEHICLE	32
WHEELS AND TIRES	33
Tire Repair	34
Wheel Installation	34
LIGHT BULB REPLACEMENT	35
Headlight	35
Taillight	35
FUSE REPLACEMENT.....	35
TRANSPORTING VEHICLE	36
Towing	36
Hauling	36
SERVICE AND MAINTENANCE.....	36
ROUTINE MAINTENANCE.....	37
TIRE INSPECTION	37
BRAKES	38
Periodic Brake Test	38
REAR AXLE	39
Checking the Lubricant Level	39
LUBRICATION	39
CAPACITIES AND REPLACEMENT PARTS	39
HARDWARE	40
BATTERY CHARGING AND MAINTENANCE	41
Safety	41
Battery Disposal	41
Battery	41
Battery Maintenance	42
At Each Charging Cycle	42
Monthly	42
Electrolyte Level and Water	42
Battery Cleaning	44
Battery Replacement	45
Prolonged Storage	45

TABLE OF CONTENTS

Battery Charging	46
AC Voltage	47
Fault Diagnosis	47
Hydrometer	47
Using A Hydrometer	48
Battery Charger Maintenance	48

PERIODIC SERVICE SCHEDULE

PERIODIC SERVICE SCHEDULE	51
---------------------------------	----

Read all of SAFETY and this section before attempting any procedure. Pay particular attention to Notices, Cautions, Warnings and Dangers.

SAFETY

GENERAL

For any questions about material in this manual, contact an authorized representative.

Read and understand all labels on the vehicle. Always replace any damaged or missing labels.

Steep hills allow the vehicle to move at faster speeds than on a flat surface. To prevent the loss of vehicle control and possible injury, speeds must be controlled to the maximum level ground speed indicated in the GENERAL SPECIFICATIONS section. Apply the brake to control the speed.

If you operate the vehicle above the maximum specified speed, you can damage the drivetrain components. Damaged drivetrain components can cause loss of vehicle control. Damage to the drivetrain caused by excessive speed is abusive, and will not be covered under the warranty.

Use caution when you tow the vehicle. Towing the vehicle at above the recommended speed can cause personal injury or damage to the vehicle and other property.

If the vehicle is used in a commercial environment, signs must be in position to inform of possible conditions that can be dangerous. Examples shown below.

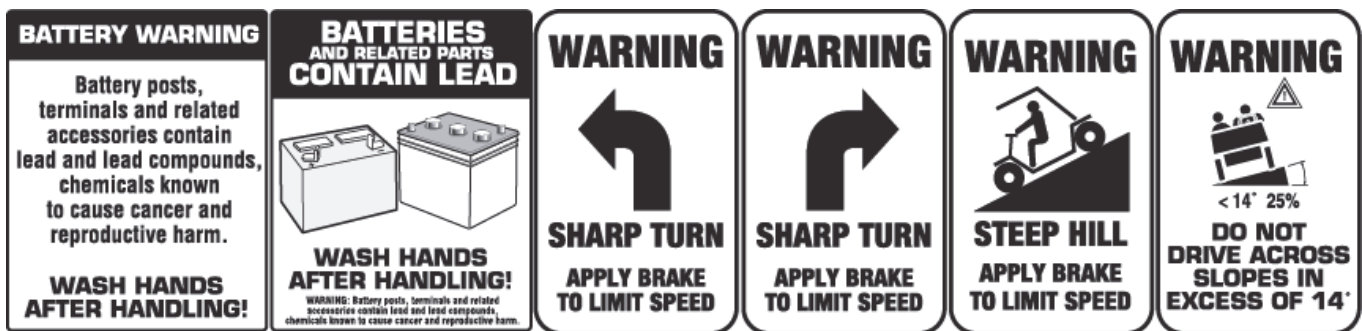

NOTICES, CAUTIONS, WARNINGS AND DANGERS

Read the **NOTICES**, **CAUTIONS**, **WARNINGS** and **DANGERS**. The person who services a vehicle needs the mechanical skill and experience to see possible hazardous conditions. Incorrect service or repairs can cause damage to the vehicle or make the vehicle dangerous to operate.

NOTICE

A **NOTICE** indicates and describes information not related to personal injury.

CAUTION

A **CAUTION** indicates a dangerous condition that can cause injury that is not life threatening.

WARNING

A **WARNING** indicates a dangerous condition that can cause death or serious injury.

DANGER

A **DANGER** indicates a dangerous condition that will cause death or serious injury.

SAFETY

Read all of SAFETY and this section before attempting any procedure. Pay particular attention to Notices, Cautions, Warnings and Dangers.

This manual contains recommended maintenance procedures from the manufacturer. Follow these procedures and fault isolation information to get the best service from the product. To decrease the risk of personal injury or property damage, read and follow all safety information and operational procedures in this manual.



CAUTION

Certain replacement parts can be used independently and/or in combination with other accessories to modify an E-Z-GO-manufactured vehicle to permit the vehicle to operate at or in excess of 20 mph. When an E-Z-GO-manufactured vehicle is modified in any way by the Distributor, Dealer or customer to operate at or in excess of 20 mph on public streets or roads. UNDER FEDERAL LAW the modified product will be a Low Speed Vehicle (LSV) subject to the strictures and requirements of Federal Motor Vehicle Safety Standard 571.500. In these instances, pursuant to Federal law the Distributor or Dealer MUST equip the product with headlights, rear lights, turn signals, seat belts, top, horn and all other modifications for LSV's mandated in FMVSS 571.500, and affix a Vehicle Identification Number to the product in accordance with the requirements of FMVSS 571.565. Pursuant to FMVSS 571.500, and in accordance with the State laws applicable in the places of sale and use of the product, the Distributor, Dealer or customer modifying the vehicle also will be the Final Vehicle Manufacturer for the LSV, and required to title or register the vehicle as mandated by State law.

Information on FMVSS 571.500 is found at Title 49 of the Code of Federal Regulations, section 571.500. For information online, go to www.ecfr.gov.

E-Z-GO will NOT approve Distributor, Dealer or customer changes that change an E-Z-GO product into a Low Speed Vehicle (LSV).

Anyone who operates this vehicle must be A LICENSED DRIVER AND OPERATE THE VEHICLE ACCORDING TO APPLICABLE STATE REQUIREMENTS. This rule is important to the SAFE USE AND OPERATION of the product. All customers must obey this SAFETY RULE.

Vehicles are used for different purposes, so it is not possible to know and inform of every possible occurrence. Be careful when you drive to prevent avoidable personal injury or damage to the vehicle. All users must read and obey this manual. Make sure you give special attention to the CAUTIONS, WARNINGS and DANGERS.

For questions about this vehicle, contact your E-Z-GO/CUSHMAN dealer or write to the address on the back cover of this publication, Attention: Customer Care Department.

E-Z-GO has the right to change the design of the vehicle. There is no responsibility to make the changes on units purchased before changes were made. The information in this manual can change without notice.

E-Z-GO IS NOT LIABLE FOR ERRORS IN THIS MANUAL. E-Z-GO IS NOT LIABLE FOR INCIDENTAL OR CONSEQUENTIAL DAMAGES THAT RESULT FROM THE USE OF THE MATERIAL IN THIS MANUAL.

This vehicle meets the current applicable standard for safety and performance requirements.

These vehicles are for off-road use. They DO NOT meet the federal Motor Vehicle Safety Standards of the United States of America (USA) and are not for operation on the public streets. Some areas allow the operation of the vehicles on their streets according to local codes.

Refer to GENERAL SPECIFICATIONS for capacity of the vehicle.



WARNING

Do not change the vehicle in any manner that changes the weight distribution, decreases stability, increases speed or extends the necessary distance to stop more than the factory specification. Such changes can cause personal injury or death.

Do not change the vehicle in any manner that changes the weight distribution, decreases stability, increases speed or extends the necessary distance to stop more than the factory specification. E-Z-GO is not responsible for changes that cause the vehicle to be dangerous.

Do not let anyone below the height of 59 inches (150 cm) operate the vehicle.

Read all of SAFETY and this section before attempting any procedure. Pay particular attention to Notices, Cautions, Warnings and Dangers.

GENERAL OPERATION

Read the following warnings before attempting to operate the vehicle.

WARNING

When you leave the vehicle, turn the key to the OFF position and remove the key from the vehicle.

Drive the vehicle only as fast as terrain and conditions allow. Consider the terrain and traffic conditions. Consider environmental conditions that change the terrain and your ability to control the vehicle.

Do not drive fast downhill. Sudden stops or change of direction can cause a loss of control. Use the brake to control the speed of the vehicle when you drive down a slope.

When possible, stay in approved areas and do not drive on steep slopes.

Always keep feet, legs, hands and arms inside vehicle.

Do not drive on rough terrain.

Before you drive in the reverse direction, make sure the area behind the vehicle is clear.

Make sure the direction selector is in the correct position before you press the accelerator pedal.

Decrease speed before and during turns.

Make sure you completely stop the vehicle before you move the direction selector.

See GENERAL SPECIFICATIONS for the vehicle load and seat capacity.

NOTICE

Read the following text and warnings before you service the vehicle.

Normal use, age, wear or abuse can cause some components on the vehicle to fail. The manufacturer can not know all possible component failures or the methods that failures can occur.

A vehicle in need of repair does not operate correctly and can be dangerous.

Be careful when you service the vehicle. Be aware of your safety and the safety of other people in the area.

Some components are heavy, spring loaded, corrosive, explosive, can cause high amperage or get hot. Battery acid and hydrogen gas can cause injury. Do not put your hands, face, feet or body in a location that can expose them to injury if an unexpected situation occurs.

Always use the correct tools shown in the tool list and wear safety equipment.

SAFETY

Read all of SAFETY and this section before attempting any procedure. Pay particular attention to Notices, Cautions, Warnings and Dangers.

WARNING

Remove all jewelry before you service the vehicle.

Do not allow loose clothing or hair to contact the moving parts.

Do not touch hot objects.



When you service the vehicle, always wear eye protection. Be careful when you do work around batteries or you use solvents or compressed air.

ALWAYS:

- Use the vehicle with responsibility and keep the vehicle in safe condition for operation.
- Read and obey all warnings and operation instruction labels on the vehicle.
- Follow all safety rules in the area where the vehicle is operated.
- When there is a risk of lightning, leave the vehicle and look for a safe location to wait until the lightning has stopped.
- Drive the vehicle only as fast as terrain and conditions allow.
- Apply brake to control the speed on steep grades.
- Keep enough distance between vehicles.
- Decrease speed in wet areas.
- Be careful when you make sharp turns, or turns you are not familiar with.
- Be careful when you drive on loose terrain.
- Be careful when you operate the vehicle around people.

MAINTENANCE

ALWAYS:

- Replace damaged or missing warning, caution or information labels.
- Service the vehicle according to the periodic service schedule in this manual.
- Make sure that approved and qualified personnel do all repairs.
- Follow the manufacturers maintenance procedures.
- Use insulated tools within the battery area to prevent sparks or battery explosion.
- Use specified replacement parts, DO NOT use replacement parts of less quality.
- Use recommended tools.
- Make sure that tools and procedures not specified by the manufacturer will not be a safety risk to personnel or operation of the vehicle.
- Support the vehicle with wheel chocks and jack stands. NEVER get below a vehicle that is supported by a jack. Lift the vehicle according to the manufacturers instructions.
- Make sure you service the vehicle in an area away from open flame or sparks.
- Know that a vehicle in need of repair does not operate correctly and can be dangerous to operate.
- After you do the repairs or maintenance, test the vehicle in a safe area that is without vehicle and person traffic.
- Make sure you record and keep all of the maintenance history of the vehicle.

Read all of SAFETY and this section before attempting any procedure. Pay particular attention to Notices, Cautions, Warnings and Dangers.

LABELS AND PICTOGRAMS

FOR INFORMATION REFER TO OWNERS MANUAL OR WEBSITE

OBEY LOCAL RULES AND REGULATIONS

USE CAUTION IN INCLEMENT WEATHER

614121

TO OPERATE VEHICLE:
- TURN KEY TO ON
- MOVE DIRECTION SELECTOR TO FORWARD OR REVERSE
- PRESS ACCELERATOR

LEAVE VEHICLE IN THREAT OF LIGHTNING

MAX SIDE SLOPE 14°

READ MANUAL FOR MAX LOAD BED CAPACITY. MAX INCLINE 14°

OPERATE FROM DRIVERS SIDE ONLY

614121

TO PARK VEHICLE:
- TURN KEY TO OFF
- MOVE DIRECTION SELECTOR TO N (ELECTRIC) OR F (GAS)
- ENGAGE PARKING BRAKE

FOR INFORMATION REFER TO OWNERS MANUAL

USE CAUTION IN INCLEMENT WEATHER

601781

NO PUBLIC ROAD USE

MAX SIDE SLOPE 14°

OPERATE FROM DRIVERS SIDE ONLY

601781

TO OPERATE VEHICLE:
- TURN KEY TO ON
- MOVE DIRECTION SELECTOR TO F OR R
- PRESS ACCELERATOR

TO PARK VEHICLE:
- TURN KEY TO OFF
- MOVE DIRECTION SELECTOR TO N (ELECTRIC) OR F (GAS)
- ENGAGE PARKING BRAKE

WARNING

Keep entire body inside car.

27653G01

WARNING

Windshields do not provide protection from golf balls or other flying objects.

EGWHL14

614068

AUTHORIZED REPRESENTATIVE IN EC IS:

RANSOMES JACOBSEN LTD.
WEST ROAD, IPSWICH,
SUFFOLK, IP3 9TT, UK

614068

HIGH CENTER OF GRAVITY MAY CAUSE TIP OVER

MAX SIDE SLOPE 14°

740499G01

WARNING READ THE MANUAL

74821G01

NO PASSENGERS IN LOAD BED

DO NOT FILL GAS CAN IN LOAD BED

MAX CENTER OF GRAVITY HEIGHT 5" OR 12 CM ABOVE FLOOR

SECURE LOAD
MAX BED WEIGHT
500 LBS or 225 KG

MAX TAILGATE LOAD 100 LBS OR 45 KG

MAX SIDE SLOPE 14°

Owner's Guide

5

SAFETY

Read all of SAFETY and this section before attempting any procedure. Pay particular attention to Notices, Cautions, Warnings and Dangers.

Notes:

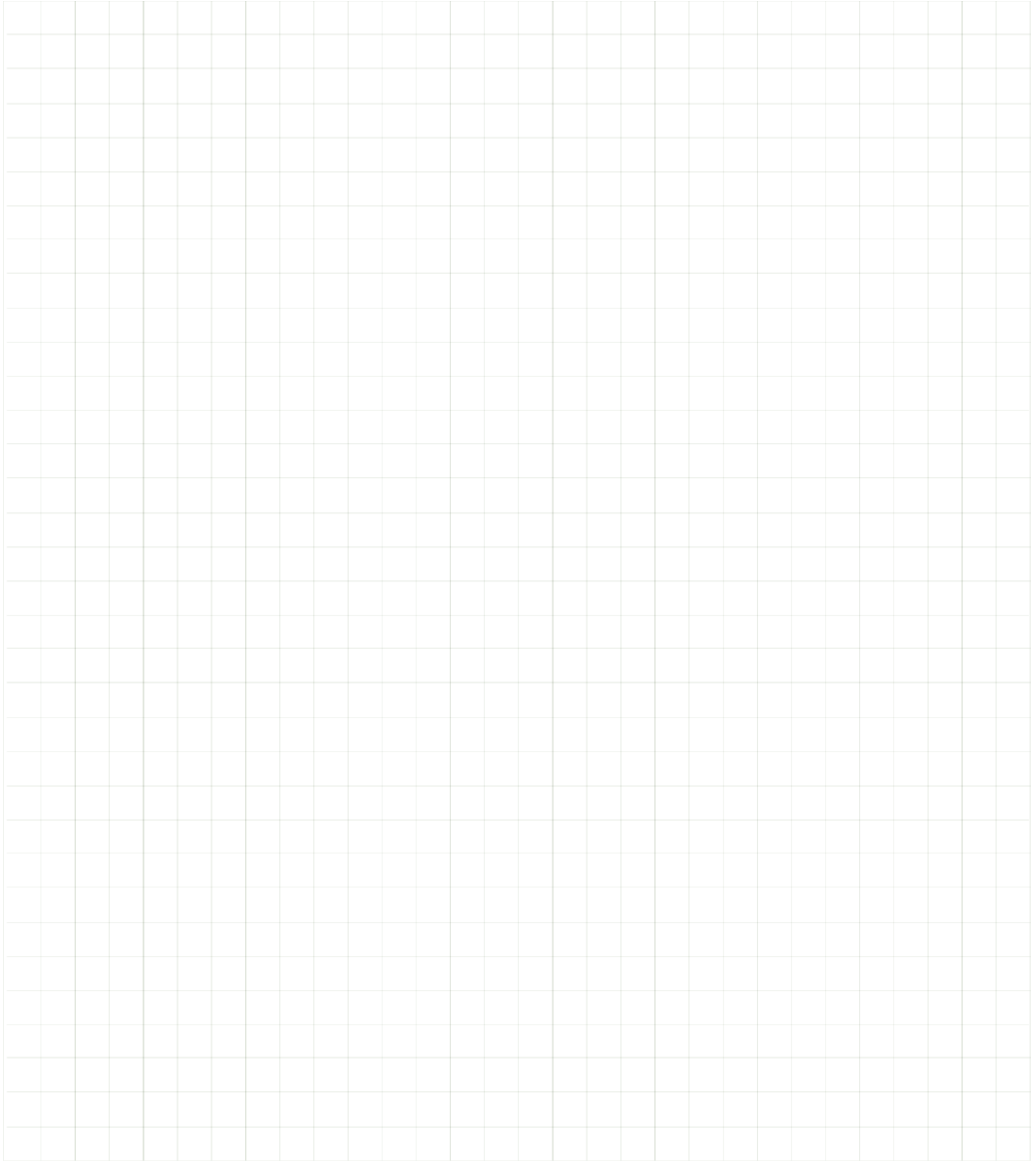
A large grid of graph paper for taking notes, consisting of 20 columns and 30 rows of small squares.

GENERAL SPECIFICATIONS

Read all of SAFETY and this section before attempting any procedure. Pay particular attention to Notices, Cautions, Warnings and Dangers.

GENERAL SPECIFICATIONS



MODEL: HAULER 800X
TYPE: ELECTRIC 48V POWERED TRUCK
MODEL YEAR: 2015
Part No: 641725



PRODUCT SPECIFICATION

CONFIGURATION HIGHLIGHTS

- TrueCourse Technology:** Programmable to multiple vehicle terrains, with expanded regenerative braking function, and vehicle charger lockout
- Solid state continuously variable separately excited speed controller
 - Dash mounted direction selector switch (Forward-Neutral-Reverse)
 - Anti-roll back, walkaway braking and alarm
 - Programmable regenerative braking, acceleration and speed
 - Six, 8 Volt deep cycle batteries
 - Full torque, reduced speed reverse
 - Inductive throttle sensor
 - Handheld vehicle diagnostics and rounds tracking
- Battery Charger:** PowerWise 48VDC high frequency, fully line compensating. 10ft (3m) DC cord. Underwriters Lab. (U.L.) Listed, (C.S.A. Certified)
- Input: 120 Volts AC, 50/60Hz, 8 amps
 - Output: 48 Volts DC at 13 amps
- Motor:** 48 Volt DC shunt wound, brazed armature, solid copper windings
- Drive Train:** Direct motor shaft connected to transaxle pinion shaft
- Electrical System:** 48 Volt DC, six, 8 volt deep cycle batteries (117 minute minimum, 170 amp-hour @ 20 hr. discharge rate)
- Transaxle:** Differential with helical gears
- Brakes:** Dual rear wheel mechanical self-adjusting drum brakes. Automatic single point park brake release with self-compensating system
- Cargo Bed:** Roto-molded cross-linked polyethylene. Lifts for access to powertrain. Removable hinged multi-position tailgate requires no latch mechanism

PRODUCT OVERVIEW

Dimensions		Gear Selection	Dash-mounted Forward-Neutral-Reverse
Overall Length	106.5 in (271 cm)	Rear Axle Ratio	12.44:1
Overall Width	48.5 in (123 cm)	Performance	
Overall Height (No Canopy)	49.0 in (126 cm) (top of steering wheel)	Seating Capacity	2 person
Overall Height (With Canopy)	71.6 in (182 cm)	Dry Weight	685 lb (315 kg) (without batteries)
Wheel Base	65.5 in (166 cm)	Curb Weight	1050 lb (475 kg)
Front Wheel Track	37.0 in (94 cm)	Bed Load Capacity	500 lb (230 kg)
Rear Wheel Track	38.0 in (97 cm)	Vehicle load capacity	800 lb (360 kg)
Gnd Clearance @ Differential	5.5 in (14 cm)	Outside Clearance Circle	18.9 ft (5.76 m)
Cargo Box Width (inside)	44.5 in (113 cm)	Intersecting Aisle Clearance	N/A
Cargo Box Length (inside)	30.5 in (77 cm)	Speed (Level Ground)	17 mph ± 0.5 mph (27.3 kph ± 0.8 kph)
Cargo Box Depth (inside)	7.5 in (19 cm)	Towing Capacity	500 lb (230 kg) max load
Cargo Box Capacity	5.9 cu ft (0.17 m ³)	Steering & Suspension	
Cargo Box material	Roto-molded polyethylene	Steering	Self-compensating rack and pinion
Vehicle Power		Front Suspension	Leaf springs with hydraulic shock absorbers
Power Source	48 Volts DC	Rear Suspension	Leaf springs with hydraulic shock absorbers
Motor Type	Shunt wound	Service Brake	Rear wheel mechanical self-adjusting drum
Horsepower (kW)	3.0 HP (2.2kW) continuous	Parking Brake	Self-compensating, single point engagement
Electrical System	48 Volt	Front Tires	Turf Saver 20 x 10 - 10 (4 Ply Rated) uni-directional
Batteries (Qty, Type)	Six, 8 Volt deep cycle	Rear Tires	Turf Saver 20 x 10 - 10 (4 Ply Rated) uni-directional
Key or Pedal Start	Pedal start	Body & Chassis	
Battery Charger	48 VDC PowerWise™ QE, 120 VAC, UL/CSA	Frame	Welded steel with DuraShield™ powder coat
Speed Controller	250 Amp solid state controller	Front Body & Finish	Injection molded TPO
Drive Train	Motor shaft direct drive	Rear Body & Finish	Steel. Base coat/clear coat
Transaxle	Differential with helical gears	Standard Color	Patriot Blue

GENERAL SPECIFICATIONS

Read all of SAFETY and this section before attempting any procedure. Pay particular attention to Notices, Cautions, Warnings and Dangers.

VEHICLE DIMENSIONS

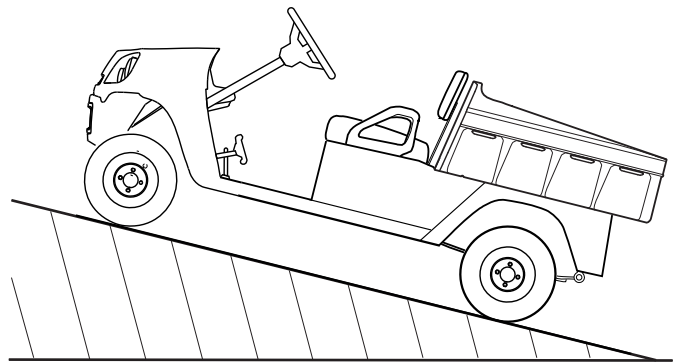
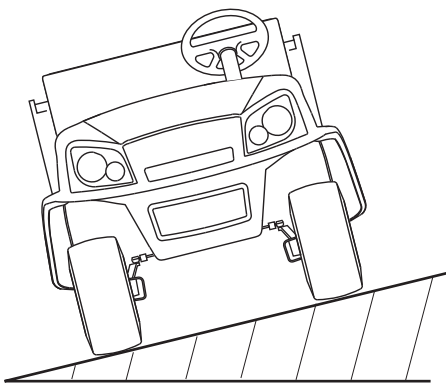
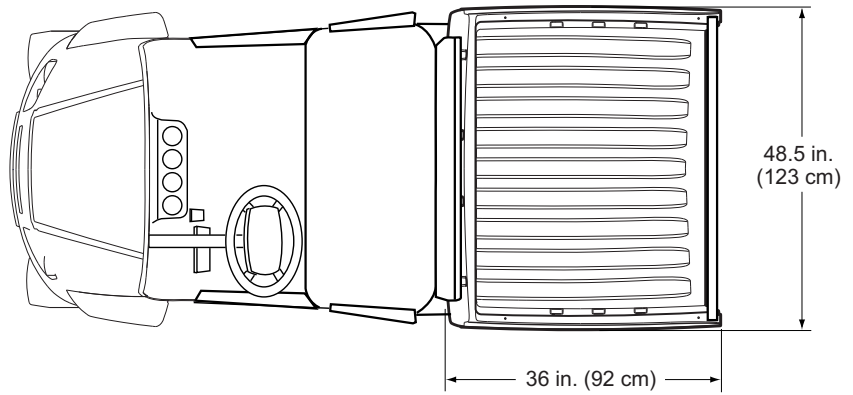
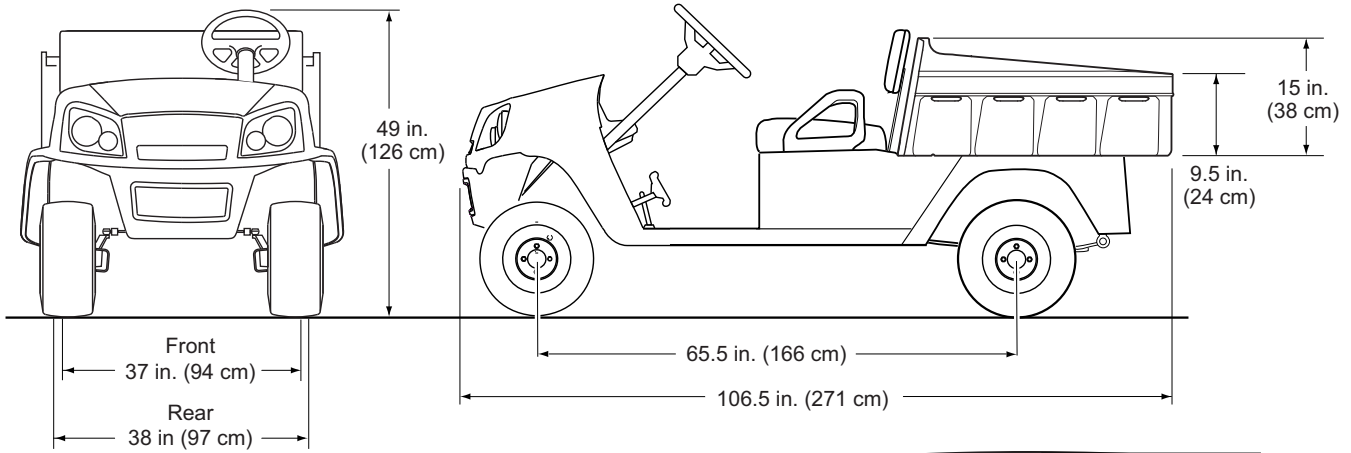

GENERAL SPECIFICATIONS

Read all of SAFETY and this section before attempting any procedure. Pay particular attention to Notices, Cautions, Warnings and Dangers.

TURNING DIAMETER AND INCLINE INFORMATION

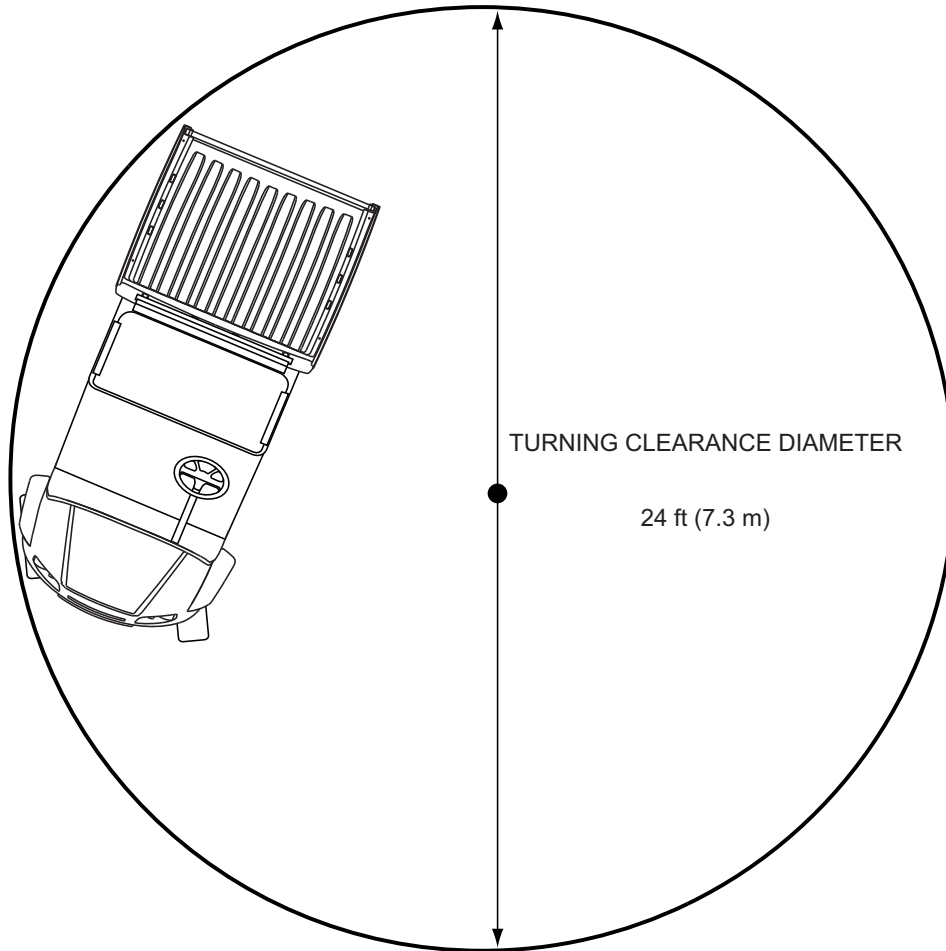

GENERAL SPECIFICATIONS

Read all of SAFETY and this section before attempting any procedure. Pay particular attention to Notices, Cautions, Warnings and Dangers.

Notes:

A large grid of graph paper for taking notes, consisting of 20 columns and 30 rows of small squares.

Read all of SAFETY and this section before attempting any procedure. Pay particular attention to Notices, Cautions, Warnings and Dangers.

INTRODUCTION

FEATURES

General Information

NOTICE

If the vehicle has accessories that were installed at the factory, some accessories continue to operate with the key switch in the OFF position.

CAUTION

ALL accessories that do NOT use the accessory wiring harness MUST be connected to the DC to DC converter to pull from the full 48-Volt battery pack. A DC to DC converter is necessary for the accessories that need voltage different from 48 volts to operate correctly.

All accessories connected to the vehicle that do not use the accessory harness must be connected to the DC to DC converter.

1. Key and Light Switch

CAUTION

To decrease the risk of component damage, stop the vehicle before you move the key switch or the direction selector.

The key and light switch is found on the instrument panel. The switch controls the basic electrical system of the vehicle and the lights. To prevent accidental operation of an unattended vehicle, turn the key to the OFF position and remove from the switch.

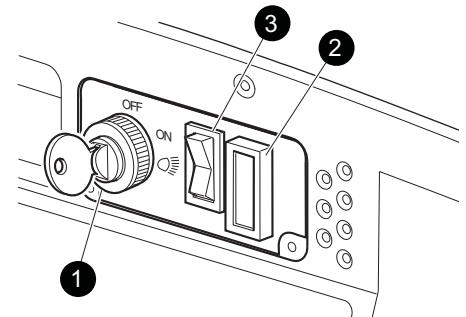

NOTICE

If the vehicle has accessories that were installed at the factory, some accessories continue to operate with the key switch in the OFF position.

2. State of Charge Meter

The state of charge meter is found on the instrument panel near the key switch. The meter indicates the amount of power within the batteries. F indicates a full charge on the battery pack and E indicates the battery pack needs to be charged.

3. Direction Selector

WARNING

To prevent loss of control, do not move the direction selector while the vehicle is in motion. If you move the selector, the vehicle speed will immediately decrease and a warning device activates.

The direction selector is found on the instrument panel next to the key switch and allows the operator to select F (forward) or R (reverse).

When you leave the vehicle, put the direction selector in neutral position (between F and R), engage the parking brake and remove the key.

When the direction selector is moved to the R position, a reverse warning buzzer activates.

INTRODUCTION

Read all of SAFETY and this section before attempting any procedure. Pay particular attention to Notices, Cautions, Warnings and Dangers.

4. Accelerator Pedal



Accidental movement of the accelerator pedal can cause the vehicle to suddenly move and cause severe injury or death.

With the key switch in the ON position, press the accelerator pedal to start the motor. When the pedal is released, the motor will stop. To stop the vehicle immediately, press the brake pedal.

5. Brake and Parking Brake Pedal

The foot operated parking brake is the top part of the brake pedal. To engage the parking brake, press on the upper section of the pedal until it locks in position. Press the lower part of the brake pedal to release the parking brake.

A parking brake that is engaged releases when you press the accelerator pedal. This is a feature to make sure the vehicle is not driven with the parking brake engaged. Pressing the accelerator pedal is not the recommended method to release the parking brake.

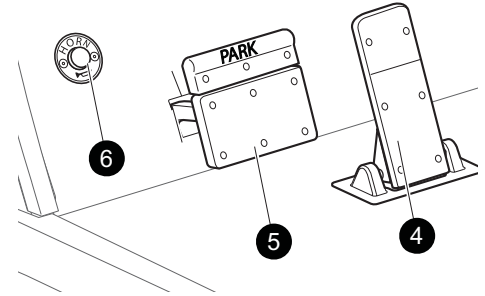

6. Horn

The horn button is found on the driver side of the floorboard. Press the button to activate the horn.

7. Turn Signal Switch (if equipped)

The turn signal switch is on the steering wheel and controls the operation of the right and left turn signals.

8. Front Seat

The front seat is for two people, one person on each side of the seat.

9. Front Hip Restraint

The front hip restraints help people stay in position if the vehicle changes position suddenly.

10. Glove Box Doors (if equipped)

The glove box doors have locks and are found on each side of the instrument panel.

11. Steering Wheel

The steering wheel controls the direction of vehicle travel.

12. Brake Light and Turn Signal Light

The brake light and turn signal assemblies are one unit. They are found on the rear fenders.

13. Truck Bed

The truck bed provides space to transport cargo.

14. Truck Bed Latch

A truck bed latch is found at the front of the manual lift truck bed.

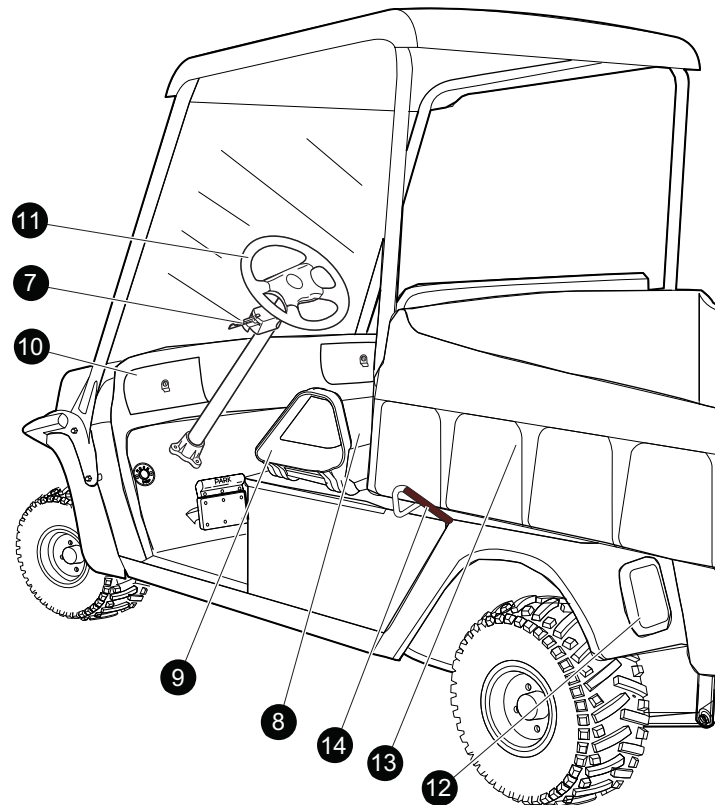

Read all of SAFETY and this section before attempting any procedure. Pay particular attention to Notices, Cautions, Warnings and Dangers.

15. Weather Enclosure (if equipped)

A weather enclosure supplies protection from strong weather conditions.

16. DC to DC Converter

The DC to DC converter supplies power to the power accessories.

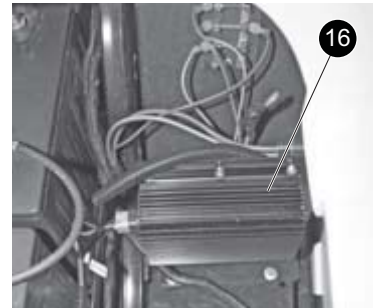

17. Charger Receptacle

Connect the charger cord to this receptacle to charge the batteries.

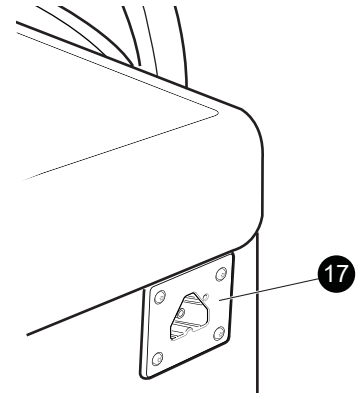

18. Battery Compartment

Lift the front seat to access the battery compartment for maintenance of the batteries and to access the run/tow switch.

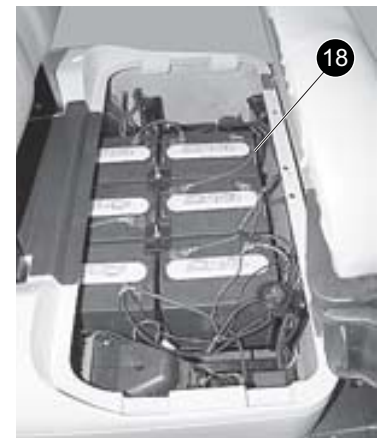

INTRODUCTION

Read all of SAFETY and this section before attempting any procedure. Pay particular attention to Notices, Cautions, Warnings and Dangers.

19. Run/Tow Switch

The run/tow switch is used when the vehicle is stopped, does not operate or removed from service. The switch is found below the seat on the passenger side of the vehicle.

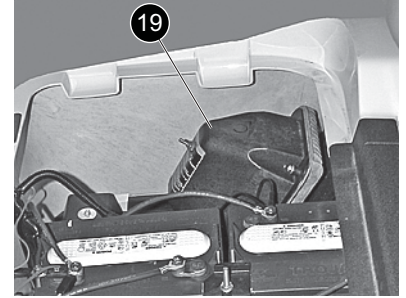

WARNING

To prevent severe injury or death caused from loss of vehicle control, set the parking brake before you move the switch to TOW position. When in TOW position, the Anti-Roll Back and Walk-Away safety features of the system do not function.

CAUTION

To decrease the risk of damage to the controller or motor, move the run/tow switch to the TOW position before you tow the vehicle.

Before you disconnect or connect a battery or any other wires, move the run/tow switch to the TOW position.

After you connect a battery or any other wires, wait a minimum of 30 seconds before you move the switch to the RUN position.

With the switch in TOW position:

- the controller is deactivated
- the electronic braking system is deactivated which allows you to tow or move the vehicle freely
- the warning beeper is deactivated

With the switch in RUN position:

- the controller is activated
- the electronic braking system and warning beeper features are activated

20. Hour Meter

The hour meter is found below the driver seat. The meter indicates total hours of vehicle operation.

21. Sun Top And Windshield (if equipped)

WARNING

The sun top does not supply protection from roll-over or falling objects.

The windshield does not supply protection from tree branches or moving objects.

The sun top and windshield supply some protection from the elements, but do not keep the operator and passenger dry in heavy rain.

Read all of SAFETY and this section before attempting any procedure. Pay particular attention to Notices, Cautions, Warnings and Dangers.

OPERATING PROCEDURES

SERIAL NUMBER LOCATION

The vehicle has two serial number and manufacture date code plates. PART C label is found on the body panel below the driver seat. PART D is found on the frame tube below the floorboard. The other (PARTS A and B) is found on the frame crossmember below the front seat. Lift the seat and the flap to access PARTS A and B

Design changes occur continuously. When you order service parts, the PIN number, manufacture date code or serial number must be available.

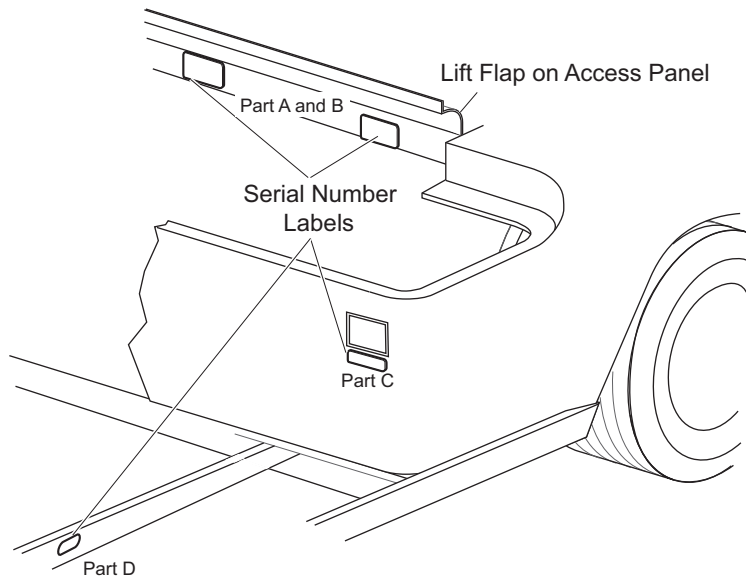

PART A	TEXTRON <small>GOLF, TURF & SPECIALTY PRODUCTS</small>		Augusta Georgia, USA 1 800 241-5855		
	MODEL <input type="text"/>				
	DATE CODE <input type="text"/>				
	SERIAL No. <input type="text"/>		Lb / kg W Batt Nom Power Hp / kw Label No.		
		<input type="text"/>		Bar Code	
PART B	Rated Capacity W/Operator lb/kg /		System voltage V		
	Lb/kg W/O Batt /		Max Draw bar lb/kg /		
	Max Batt lb/kg /		/		
		<input type="text"/>			
PART C/D	SERIAL No. <input type="text"/>				
	<input type="text"/>				
				Bar Code	

BEFORE INITIAL USE

Read, understand and follow the safety label on the instrument panel. Make sure you understand how to safely operate the vehicle and its equipment.

WARNING

Reckless use of this vehicle can cause severe injury or death. This vehicle is a light-duty vehicle, NOT an All Terrain Vehicle (ATV).

Do not engage in rough or reckless operation of this vehicle.

If you do not know the terrain, make sure you prepare for unexpected occurrences. If the vehicle gets stuck or the batteries discharge, a one-hour drive can take many hours on foot.

Explosive hydrogen gas is created during the charge cycle of batteries. Do not charge batteries without enough ventilation. A 4% concentration of hydrogen gas is explosive.

To prevent battery explosion, keep all flammable materials, open flame or sparks away from the batteries.

OPERATING PROCEDURES

Read all of SAFETY and this section before attempting any procedure. Pay particular attention to Notices, Cautions, Warnings and Dangers.

Explosive hydrogen gas is created during the charge cycle of the batteries. Good ventilation is necessary to remove gas from closed spaces. The air must change every 12 minutes.

Never charge a vehicle near flammable materials, open flame or sparks. Never charge a vehicle near gas water heaters and furnaces.

Before a new vehicle is put into operation, complete the items shown in the **INITIAL SERVICE CHART**.

INITIAL SERVICE CHART	
Item	Service Operation
Portable Charger	Remove from vehicle and correctly install.
Batteries	Charge the batteries.
Seats	Remove the protective plastic cover.
Brakes	Check the operation.
	Calculate the distance necessary to stop the vehicle for the brake performance test.
Tires	Check air pressure (18-22 psi).
General	Check for possible leaks that may have started during shipment.

PORTABLE CHARGER INSTALLATION

DANGER

Risk of electric shock. Connect the charger power cord to an outlet that is correctly installed and connected to an electrical ground according to all codes and regulations. A grounded outlet is necessary to decrease the risk of electric shock – do not use ground adapters or replace the plug. Do not touch parts of output connector or battery terminals that do not have insulation.

DANGER

Disconnect the DC plug before you make or break the connections to a battery that is charging. Do not open or disassemble the charger. Do not operate the charger if the AC cord is damaged. Make sure qualified personnel does all repair work to the charger.

WARNING

Do not allow children to use the charger.

To prevent over-heating that can cause damage to the charger and possible fire, keep the air fins clear. Install portable chargers on a platform above the ground to allow maximum air flow around and below the charger.

Use the charger on 48-volt battery systems. Other use can cause personal injury and damage.

Lead acid batteries can create explosive hydrogen gas during normal operation. Keep sparks, flames and flammable materials away from batteries.

OPERATING PROCEDURES

Read all of SAFETY and this section before attempting any procedure. Pay particular attention to Notices, Cautions, Warnings and Dangers.

Supply enough ventilation during the charge cycle.

Never charge a frozen battery.

Read all of the manufacturers specified precautions for the battery. For example, recommended rates of charge and removal of cell caps during charge cycle.

Portable chargers are supplied with the vehicles. Before vehicle or charger operation, remove the charger from the vehicle. **A dedicated circuit is necessary for the charger.** Refer to the charger manual for correct circuit protection. For best performance and shortest charge times, put the charger in an area with good ventilation.

The list below supplies points to keep the charger cool while in operation.

- Put the charger in an area that is without dirt, mud or dust to prevent build-up in the charger fins.
- Put the charger on a horizontal surface with the fins vertical.
- Put the charger on a platform above the ground to allow air to flow around and below the charger.

If the charger is operated in an outdoor location, rain and sun protection must be supplied.

Because the charger can get hot during operation, install in an area with minimum person traffic to decrease possible contact with hot charger.

Make sure the status display on the charger is visible to the user.

NOTICE

Put the DC cord through the center of the steering wheel to remind you to put the cord away when finished with the charger. You can damage the DC plug if you drive over or catch the cord on the vehicle when you drive away.

WARNING

To decrease the risk of electrical shock or electrocution, make sure that the charger plug is not damaged and is correctly connected to a grounded outlet.

The power AC cord has a plug with a ground post. Do not remove, cut or bend the ground post.

WARNING

The charger DC cord has a polarized connector which fits into a receptacle on the vehicle.

NOTICE

If the vehicle is charged with a charger different from the one supplied with the vehicle, refer to the instructions supplied with the charger used.

OPERATING PROCEDURES

Read all of **SAFETY** and this section before attempting any procedure. Pay particular attention to **Notices, Cautions, Warnings and Dangers.**

Provide Protection From Elements



Keep cooling fins clean and free of dirt and debris



NEMA 15 - 5R Grounded AC Receptacle

110 - 120 VAC. Dedicated 15 AMP Circuit

Locations outside the US and Canada: Reference appropriate local electrical code and charger manufacturer recommendations for AC power requirements

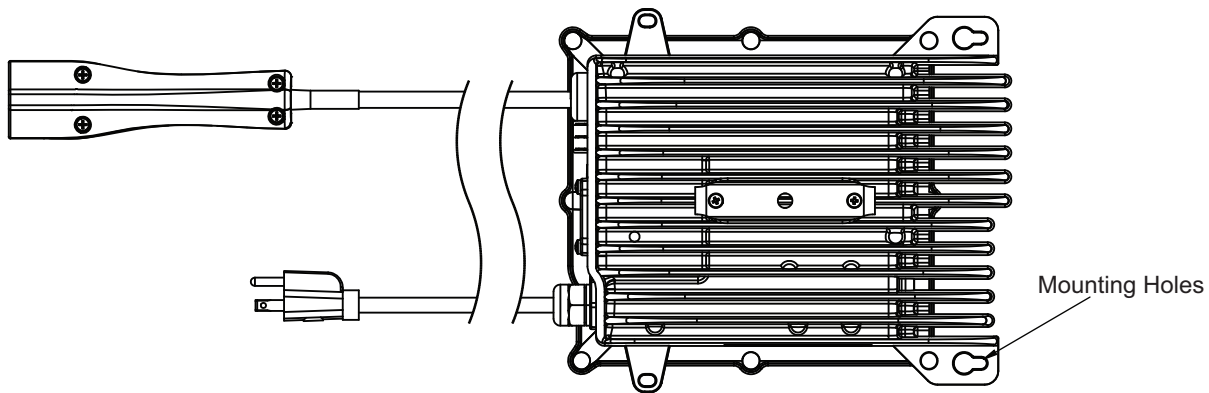
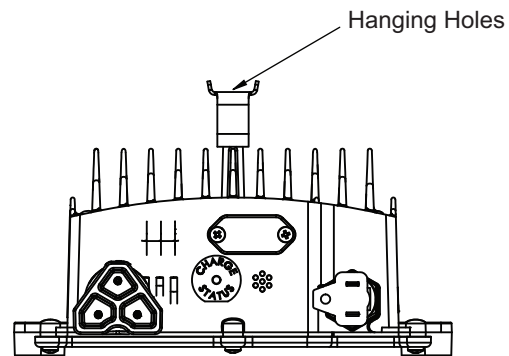

UNDERSTAND THE CHARGER

When the charger is connected to the vehicle, the vehicle will not operate. When the charger is connected to the vehicle, the charger will automatically turn on. The LED lights on the charger and the vehicle flash GREEN to indicate the charge cycle has started.

When minimum voltage of 2 volts per cell (VPC) is reached, the charger output electric current will change from full electric current to trickle electric current. The length of charge time depends on how discharged the batteries are, the input AC voltage and charger ambient temperatures.

The charger LED light will give a SHORT flash if the charge is less than 80%. The charger LED light will give a LONG flash if the charge is more than 80%. SOLID GREEN indicates that the batteries are completely charged and you can disconnect the charger, but it is not necessary. The charger can stay connected to keep the batteries charged.

If a fault occurred during the charge cycle, the charger LED will quickly flash RED. The specified fault is indicated by the number of RED flashes that occur, a pause, and the RED flashes repeat again. Errors are caused by different conditions. Some errors need a person to correct the problem and then reset the charger. Disconnect the DC cord from the vehicle to reset the charger.

If the AC voltage is interrupted and restored, the charger will automatically turn on again.

LED Operation Codes

- SHORT GREEN FLASH = less than 80% of charge capacity
- LONG GREEN FLASH = more than 80% of charge capacity
- SOLID GREEN = 100% of charge capacity
- RED FLASH = fault code

Read all of SAFETY and this section before attempting any procedure. Pay particular attention to Notices, Cautions, Warnings and Dangers.

LED Fault Codes

- **RED FLASH:** The light turns on quickly, and does not flash after that - check for valid AC voltage.
- **ONE RED FLASH:** One flash, a pause, and another flash and a pause
 - Charge Enable Fault: Bad contact in the DC connector or dirty contacts.
 - Battery Temperature Fault: Battery temperature is more than 122° F (50° C) or less than 14° F (-10° C).
- **TWO RED FLASHES:** Two flashes, a pause and another two flashes and a pause
Battery Voltage Fault: The battery pack is less than 48.0 Volts or more than 67.2 Volts. The battery pack is discharged too much or over charged for the charger to operate.
- **THREE RED FLASHES:** Three flashes, a pause and another three flashes and a pause
Battery Charge Time-out: Charge time more than 24 hours. This fault can indicate a problem with the battery pack or that the charger output electric current decreased because of high ambient temperatures.
- **FOUR RED FLASHES:** Four flashes, a pause and another four flashes and a pause
Battery Fault: Charge time exceeded. This fault indicates that the battery pack voltage did not reach the necessary minimum level within the maximum time allowed.
- **SIX RED FLASHES:** Six flashes, a pause and another six flashes and a pause
Charger Fault: A fault inside the charger was sensed. Disconnect the charger DC power cord and connect again. If the fault is sensed after that, take the charger to an approved service center.

WARNING

To decrease the risk of electrical shock or electrocution, make sure that the charger plug is not damaged and is correctly connected to a grounded outlet.

The power AC cord has a plug with a ground post. Do not remove, cut or bend the ground post.

The charger DC cord has a polarized connector which fits into a receptacle on the vehicle. The receptacle is found on the driver side of the vehicle below the seat.

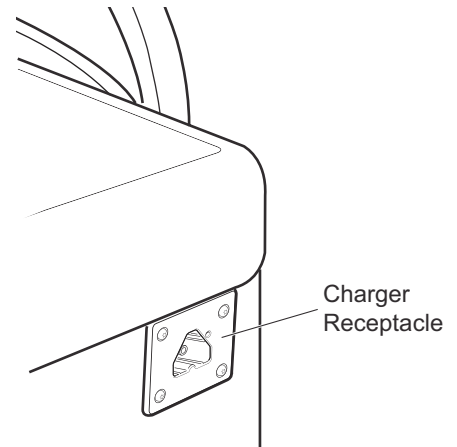

HOW TO USE THE CHARGER

The charger can stay connected to the AC outlet after the charge cycle is complete.

To charge the vehicle, refer to the instruction labels on the charger.

Completely connect the DC plug into the vehicle receptacle. The charger will automatically start seconds after the plug is in position. The charger will automatically stop when the batteries are charged. Remove the DC plug before you operate the vehicle.

CHARGER MAINTENANCE

1. Make sure the charger connections to the battery terminals are tight and clean. Check for damage or cracks in the plastic parts.
2. Inspect the charger harness for wear and check the areas that contact other components. Inspect all wires for wear, loose terminals, corrosion or damage to the insulation.
3. Clean dirt and any other particles from the cooling fins. Keep the charger away from oil, dirt and mud. Do not allow water to spray on the charger when you clean equipment.
4. Inspect the plug of the battery charger and the vehicle receptacle housing for dirt or dust. Clean a minimum of once a month.

OPERATING PROCEDURES

Read all of SAFETY and this section before attempting any procedure. Pay particular attention to Notices, Cautions, Warnings and Dangers.

HOW TO OPERATE THE VEHICLE



CAUTION

Incorrect use of the vehicle or lack of maintenance can cause damage or decreased performance.

Read the following warnings before you operate the vehicle.



WARNING

Make sure you know the terrain and traffic conditions. Make sure you know environmental conditions that change the terrain and your ability to control the vehicle. Drive the vehicle only as fast as terrain and conditions allow.

When possible, stay in approved areas and do not drive on steep slopes.

Do not drive fast downhill. Sudden stops or change of direction can cause a loss of control. Use the brake to control the speed of the vehicle when you drive down a slope.

To prevent loss of control, do not move the direction selector while the vehicle is in motion. If you move the selector, the speed will immediately decrease and a warning device activates.

Decrease speed before and during turns.

Do not drive the vehicle up, down, or across a slope that is more than 14° (25% grade).

See GENERAL SPECIFICATIONS for the vehicle load and seat capacity.

When the accelerator pedal is pressed, the foot-operated parking brake releases and can cause accidental or sudden vehicle movement. When the vehicle is parked, make sure the key is in the OFF position.

When you leave the vehicle, turn the key to the OFF position and remove from the switch to prevent accidental operation.

Make sure the direction selector is in correct position before you press the accelerator pedal.

Make sure you completely stop the vehicle before you move the direction selector to a different position.

Do not put the vehicle in neutral while in motion (coast).

Before you drive in the reverse direction, make sure the area behind the vehicle is clear.

Driver and passengers must stay in their seats while the vehicle is in motion.

Always keep feet, legs, hands and arms inside vehicle while in motion.

Incorrect and irresponsible operation of this vehicle can cause dangerous conditions for the operator, passengers and other people in the area. Do not allow children or anyone without a license to operate the vehicle. Children may not have the skill and ability to make good decisions or strength to operate the vehicle.

Drugs and alcohol decrease the ability of the driver to operate the vehicle safely. Always check with a medical professional before you operate the vehicle.

Read all of SAFETY and this section before attempting any procedure. Pay particular attention to Notices, Cautions, Warnings and Dangers.

When you drive the vehicle at full speed on a dirt road, loose surface or wet grass, the necessary distance to stop the vehicle will increase. The necessary distance to stop a loaded vehicle is more than the necessary distance to stop a vehicle without a load. In wet weather conditions, apply light pressure to the brakes to supply enough friction to dry the brake unit. Wet brakes lose much of their effect.

If you drive on a steep hill and can not get enough traction, **do not try to turn around on the hill**. Slowly drive in the reverse direction and use the brake to control the speed.

Key and Headlight Switch Operation

WARNING

When you leave the vehicle, turn the key to the OFF position and remove from the switch to prevent accidental operation.

CAUTION

To prevent possible damage to the components, stop the vehicle before you move the key switch or the direction selector to a different position.

Turn the key to the right to enable the electrical system of the vehicle. The first stop is ON and supplies power that allows you to drive the vehicle. The second stop has a light icon and activates the lights.

When you leave the vehicle, turn the key to the OFF position and remove the key from the switch.

NOTICE

If the vehicle has accessories that were installed at the factory, some accessories continue to operate with the key switch in the OFF position.

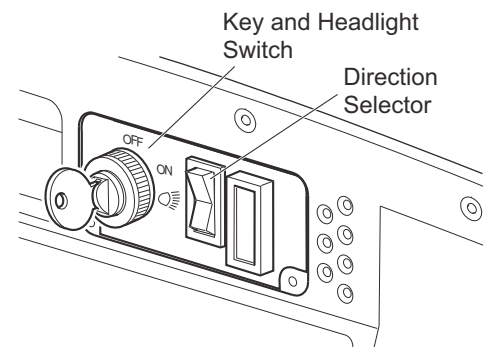

Direction Selector Operation

WARNING

To prevent loss of control, do not move the direction selector to a different position while the vehicle is in motion. If you move the selector, the speed will immediately decrease and a warning device activates.

Move the direction selector to F to move in the forward direction.

Move the direction selector to R to move in the reverse direction. A reverse warning buzzer activates when the direction selector is moved to the R position.

The position between F and R is the neutral position.

When you leave the vehicle, put the direction selector in the neutral position, engage the parking brake and remove the key from the switch.

OPERATING PROCEDURES

Read all of SAFETY and this section before attempting any procedure. Pay particular attention to Notices, Cautions, Warnings and Dangers.

Accelerator Pedal Operation

WARNING

Accidental movement of the accelerator pedal can cause the vehicle to suddenly move and cause severe injury or death.

An engaged parking brake will release when the accelerator pedal is pressed and cause the vehicle to move suddenly. When the vehicle is parked, make sure the key is in the OFF position so that the electrical system is disabled.

When the key switch is in the ON position, press the accelerator pedal start the motor and move the vehicle. Release the pedal to stop the motor.

Press the brake pedal to stop the vehicle quickly.

If the key switch is in the ON position and the parking brake is engaged, the brake releases when you press the accelerator pedal and can cause the vehicle to move suddenly. This is a feature to make sure the vehicle is not driven with the parking brake engaged. Pressing the accelerator pedal is not the recommended method to release the parking brake.

Brake and Parking Brake Operation

The function of the lower part of the brake pedal is to control speed. Press the lower part of the pedal to decrease speed or stop the vehicle.

To engage the parking brake, press the upper section of the pedal until it locks into position. Press the lower part of the pedal to release the parking brake.

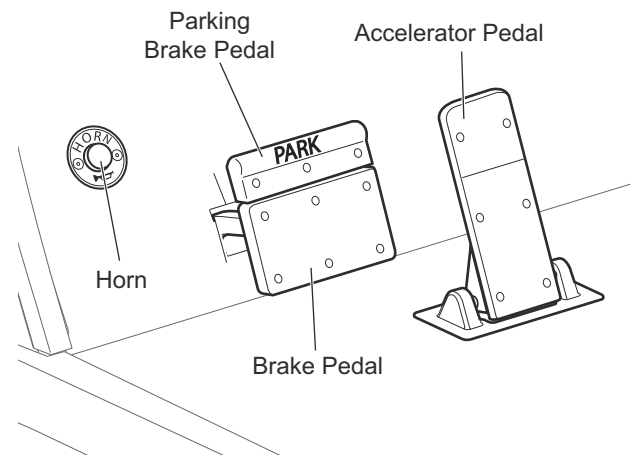

Horn Operation

Press the horn button to activate the horn.

Run/Tow Switch Operation

WARNING

Make sure the vehicle is on a level surface and set the parking brake before you move the switch to TOW position. When in TOW position, the Anti-Roll Back and Walk-Away safety features of the system does not function.

CAUTION

To decrease the risk of damage to the controller or motor, move the run/tow switch to the TOW position before you tow the vehicle.

Before you disconnect or connect a battery or any other wires, move the run/tow switch to the TOW position.

After you connect a battery or any other wires, wait a minimum of 30 seconds before you move the switch to the RUN position.

OPERATING PROCEDURES

Read all of SAFETY and this section before attempting any procedure. Pay particular attention to Notices, Cautions, Warnings and Dangers.

With the switch in TOW position:

- the controller is deactivated
- the electronic braking system is deactivated which allows the vehicle to be towed or roll freely
- the warning beeper is deactivated

With the switch in RUN position:

- the controller is activated
- the electronic braking system and warning beeper features are activated.

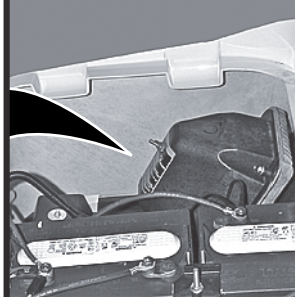
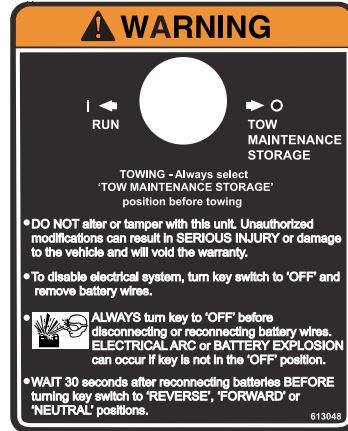

Truck Bed Operation

⚠ WARNING

Failure to follow these instructions can cause personal injury, damage the vehicle or cause the vehicle to tip over. Be aware of the load when you operate the vehicle. Read, understand and follow the warning label attached to the front of the load bed.

Do not allow passengers to ride in the truck bed. A sudden move or stop can cause severe injury or death to passengers in the truck bed.

Before operating, make sure no one is behind the vehicle.

A load bed warning label is attached to the inside front of the truck bed. Understand and obey the warnings on this label for safe operation of the vehicle.

- See the load bed warning label for maximum load.
- Position the load in the truck bed as far forward as possible.
- Make sure the center of gravity of the load is within the height limit shown on label.
- Secure the load to the truck bed.
- Be aware of the load when you operate the vehicle.
- Do not let passengers to ride in the truck bed. Do not drive the vehicle with the truck bed lifted or with the tailgate unsupported.

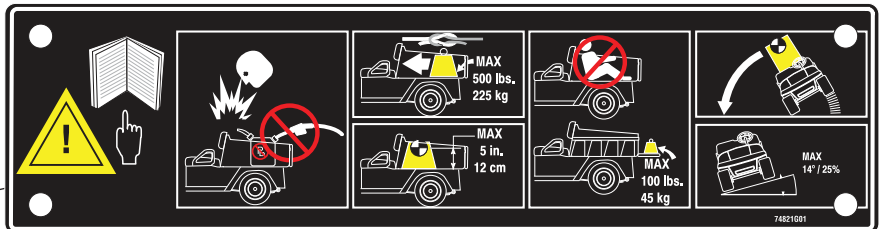
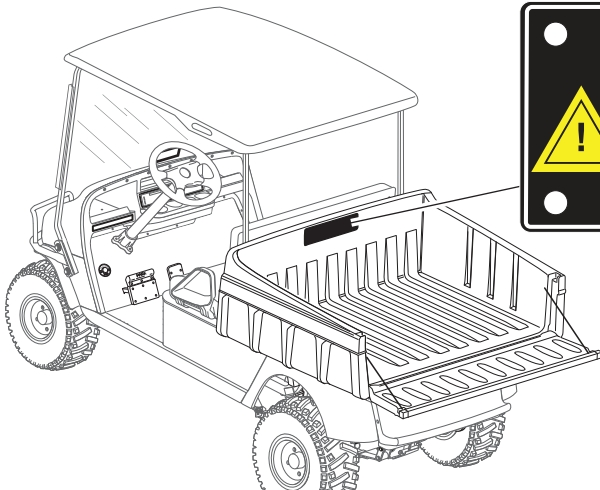

OPERATING PROCEDURES

Read all of SAFETY and this section before attempting any procedure. Pay particular attention to Notices, Cautions, Warnings and Dangers.

WARNING

Never fill a gas container in the truck bed. Static discharge can ignite gasoline vapor and cause an explosion.

Always put the gas container on the ground before you fill with gas. Never fill a gas container in the truck bed. Static electricity is built up during the fueling process and can discharge and cause the gasoline vapor to ignite.

Truck Bed Latch Operation

WARNING

Use caution when you operate the truck bed latch to make sure the truck bed does not accidentally drop during lift or lower procedure. If the truck bed drops, fingers or other body parts can be trapped.

To lift the truck bed, pull up the latch release handle behind the driver seat. Use the latch handle to lift up on the truck bed.

Use the latch handle to lower the truck bed into the resting position. Make sure your hands are not trapped by the truck bed.

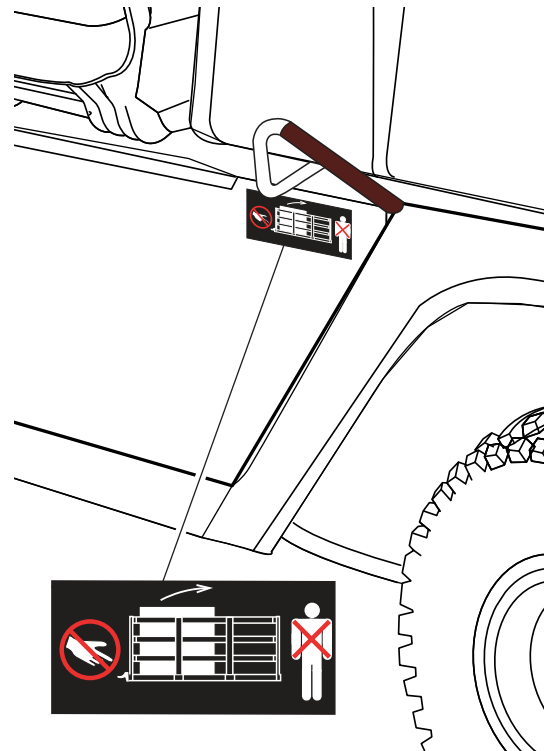

Tailgate Operation

Open the tailgate:

- Lift the tailgate upward with a sharp pull
- Pivot out for open position

Remove the tailgate:

- Remove the side cables from the truck bed
- Open the tailgate and allow to swing completely down
- Lift the tailgate upward to remove from the pins and the truck bed.

Read all of SAFETY and this section before attempting any procedure. Pay particular attention to Notices, Cautions, Warnings and Dangers.

TRUCOURSE TECHNOLOGY SYSTEM™ (TCT)

Performance Options

TruCourse Technology (TCT) system vehicles are operated in one of four performance options. All options have standard features that control, protect and diagnose the vehicle. The options are described as follows:

- **Option 1 - Flat**
The motor speed is sensed and limited to top speed of 14.8 mph (23.8 kph) by the controller. As the vehicle reaches the top of a hill and starts to move down the hill, the speed is limited to a top speed of 14.8 mph (23.8 kph).
- **Option 2 - Steep Hill**
This option includes all of the features of the Flat option plus pedal-up braking. Pedal-up braking occurs when the accelerator pedal is released on a moving vehicle. The motor will decrease the speed of the vehicle until the accelerator pedal is pressed again or the vehicle comes to a stop. This option is the stronger of the two hill performance options (2 and 3).
This is the 12.8 mph (20.6 kph) option.
- **Option 3 - Mild Hill**
This option is the same as the Steep Hill option, except that the pedal-up braking affect is not as strong.
This is the 13.8 mph (22.2 kph) option.
- **Option 4 - Freedom**
This option is the same as the Flat option, except that the flat ground and downhill top speeds are limited to 18.5 mph (29.7 kph) instead of 14.8 mph (23.8 kph).

Put the vehicle in diagnostic mode to determine the current vehicle performance option. The number of beeps heard immediately after you enter diagnostic mode agrees with the option for each option numbers.

How to Change Performance Options

You can change the performance option as needed to best suit the terrain you are driving on.

1. Lift the seat and make sure that the run/tow switch is in the RUN position.
2. Make sure that the charger is disconnected from the vehicle.
3. Find the vehicle diagnostic port and remove the environmental cover.
4. Connect the handheld diagnostic tool and select the correct performance setting.
5. Disconnect the handheld diagnostic tool, replace the environmental cover and seat.

Performance Option	Top Speed	Pedal-up Braking Strength	Anti-Stall Protection
1. Flat	14.8 mph (23.8 kph)	None	Yes
2. Steep Hill	12.8 mph (20.6 kph)	Heavy	Yes
3. Mild Hill	13.8 mph (22 kph)	Mild	Yes
4. Freedom	18.5 mph (29.7 kph)	None	Yes

OPERATING PROCEDURES

Read all of SAFETY and this section before attempting any procedure. Pay particular attention to Notices, Cautions, Warnings and Dangers.

TCT Operation

With the switch in TOW position:

- the controller is deactivated
- the electronic braking system is deactivated which allows the vehicle move freely
- the warning beeper is deactivated

With the switch in RUN position:

- the controller is activated
- the electronic braking system and warning beeper features are activated

NOTICE

A TCT vehicle operates in the RUN position only.

With the switch in RUN position and all of the following occurrences:

- the vehicle is stopped for more than one second
- the accelerator pedal is released for more than one second
- the vehicle starts to roll more than 2 mph (3 kph)

the pedal-up brake system limits the speed to approximately 2 mph (3 kph) and the warning beeper activates. When the accelerator pedal is pressed, the pedal-up brake and warning beeper stops and normal operation continues. The system functions in all key switch positions.

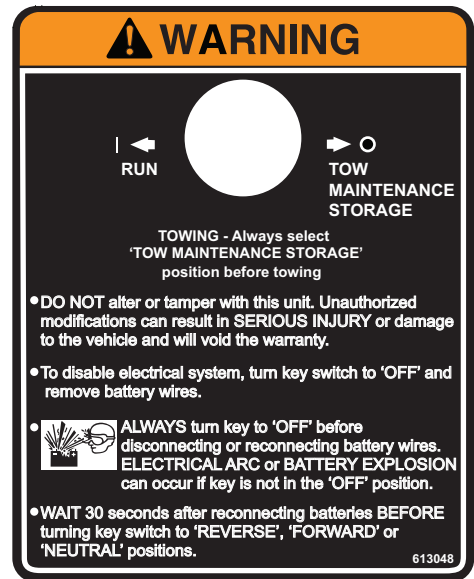

WARNING

The TCT system is not a alternative for the brake. Use the brake pedal to control speed and decrease the risk of injury.

With the switch in RUN position and all of the following occurrences:

- the vehicle being driven down a slope
- the vehicle speed is more than the specified top speed with the accelerator pedal pressed **or** released

the pedal-up brake limits the speed of the vehicle to the specified top speed. When the regenerative braking feature is activated by this sequence of occurrences, the motor generates power which is returned to the batteries.

Test the TCT system each month. Allow the vehicle to move downhill with the accelerator pedal released. The braking force must be felt at approximately 2 mph (3 kph) indicating that the TCT system is in operation. If the speed continues to increase, apply the brake to control speed and continue with diagnostic check.

NOTICE

When you charge the vehicle, the diagnostic mode is deactivated and the handheld diagnostic tool does not operate. The run/tow switch is found below the passenger side of the seat on the ESC environmental cover.

Read all of SAFETY and this section before attempting any procedure. Pay particular attention to Notices, Cautions, Warnings and Dangers.

General

The motor speed is sensed and controlled by the controller. When the vehicle moves faster downhill, the speed sensor causes the motor to electrically control the speed of the vehicle through regenerative braking.

If the operator tries to override the electronic brake feature by moving the direction selector or key switch to another position, the warning beeper activates and the vehicle brakes **quickly** until it reaches the speed of approximately 2 mph (3 kph).

The TCT system also includes an anti-stall protection feature that prevents commutator damage from stalling the vehicle against an obstruction or ascending a hill. The electrical power to the motor deactivates and allows the vehicle to roll freely before damage is done.

Each performance option features different degrees of breaking strength that occurs when the accelerator pedal is released. See "Performance Options" on page 25 for information specific to each option.

The TCT controller is a low power usage unit, but drains the vehicle batteries over time. If the vehicle is stored for a long period of time, put the run/tow switch in the TOW position to disconnect the controller from the batteries.

The Electronic Speed Control system has three separate units:

- pedal box
- speed sensor
- controller

TCT features include:

- regenerative braking
- pedal-up braking
- walk-away
- anti-roll back
- anti-stall
- high pedal disable
- diagnostic mode

See the following sections for information specific to each feature.

Regenerative Braking Feature

All TCT vehicles have a regenerative motor control system. When the regenerative braking system is activated, the motor generates power which is returned to the batteries.

Example: If all of the following events occur:

- the vehicle being driven down a slope
- the vehicle speed is more than the specified top speed with the accelerator pedal pressed **or** released

the regenerative brake will limit the speed of the vehicle to the specified top speed but the warning beeper will **not** activate.

If the operator tries to override the electronic brake feature by moving the direction selector or key switch to another position, the warning beeper activates and the vehicle brakes **quickly** until it reaches approximately 2 mph (3 kph).

Pedal-Up Braking Feature

Pedal-up braking is regenerative braking that occurs when the accelerator pedal is released and the vehicle in motion between 8 mph (13 kph) and the vehicle top speed.

Example: If all of the following events occur:

- the vehicle being driven down a slope
- the accelerator pedal is released for more than one second

pedal-up braking decreases speed to 8 mph (13 kph), the vehicle can move freely without the accelerator pressed,

OPERATING PROCEDURES

Read all of SAFETY and this section before attempting any procedure. Pay particular attention to Notices, Cautions, Warnings and Dangers.

between 8 and 3 mph (5 kph), or the accelerator pedal is applied. The warning beeper will **not** activate. When pedal-up braking is activated by this sequence of occurrences, the motor generates power which is returned to the batteries.

Walk-Away Feature

Walk-Away limits vehicle movement without driver input, decreases vehicle speed to 2 mph (3 kph) and activates an alarm (reverse beeper).

Example: If all of the following events occur:

- the vehicle is stopped for more than 1.5 seconds
- the accelerator pedal is released for more than one second
- the vehicle starts to move at more than 2 mph (3 kph)

the Walk-Away feature limits speed to approximately 2 mph (3 kph) and the warning beeper activates. When the accelerator pedal is pressed, the Walk-Away feature and warning beeper stops and normal vehicle operation continues.

When the TCT system senses any condition that is not normal, it responds in a similar manner.

The system functions in all key switch positions.

Anti-Roll Back Feature

Anti-Roll Back, like Walk-Away, limits reverse motion of the vehicle down a slope to less than 2 mph (3 kph). See Walk-Away Feature for more information.

Anti-Stall Feature

Anti-Stall protection prevents motor damage if the vehicle is stalled against an object or on a hill.

Example: If all of the following events occur:

- the system senses that the accelerator pedal is pressed (power applied to motor)
- the motor is stopped long enough that additional time can cause damage to the motor

the Anti-Stall feature will interrupt power to the motor. This short interruption allows the vehicle to move backward slightly before it stops again. The procedure will repeat at intervals until the vehicle is moved from the stopped condition.

Example: If all of the following events occur:

- the system senses that the accelerator pedal is pressed (power applied to motor)
- the brake is engaged to prevent vehicle motion

the Anti-Stall feature senses a stalled motor condition and removes power from the motor. When the brake pedal is released, the vehicle will move backward slightly before power is returned to the motor.

High Pedal Disable Feature

High pedal disable prevents acceleration of the vehicle if the direction selector is changed or the key is turned on while the accelerator is pressed.

Diagnostic Mode Feature

Diagnostic mode helps with fault diagnosis.

With some electrical system failures, the Diagnostic Mode feature defaults to a mode that allows the vehicle to operate at a decreased speed.

This feature allows you to return the vehicle to the storage facility and identify the problem.

The technician can put the controller in diagnostic mode and the controller identifies the failure mode.

Read all of SAFETY and this section before attempting any procedure. Pay particular attention to Notices, Cautions, Warnings and Dangers.

STARTING AND DRIVING

WARNING

To decrease the risk of roll-back, do not release the brake pedal until the motor has started.

All vehicles have an *interlock system* that disables the controller and prevents operation or tow of the vehicle while the charger is connected. Remove the charger plug from the receptacle and correctly store the cable before you move the vehicle.

To operate the vehicle:

- Apply the brake, put the key in the key switch and turn to the ON position.
- Move the direction selector to the correct direction.
- Press the brake pedal to release the parking brake.
- Slowly press the accelerator pedal to start the motor and release the brake pedal.
- When the accelerator pedal is released, the motor decreases the speed of the vehicle. To stop the vehicle quickly, press the brake pedal.

NOTICE

When the direction selector is in the reverse position, a warning signal activates to indicate that the vehicle is ready to run in the reverse direction.

Starting Vehicle On A Hill

WARNING

To decrease the risk of roll-back, do not release the brake until the motor has started.

CAUTION

Do not use the accelerator and motor to hold the vehicle on a hill. Doing so for more than 3 - 4 seconds will cause permanent damage to motor.

To decrease the risk of permanent damage to the drive system, do not allow roll-back when you start the vehicle on a hill.

Put left foot on the brake pedal and release the parking brake. Press the accelerator with right foot and release the brake pedal.

Terrain

The vehicle is for use on improved roads; do not use on public highways. You can operate the vehicle on dirt roads or open terrain that is free from fallen trees, branches, large rocks or holes.

Do not drive the vehicle through water.

OPERATING PROCEDURES

Read all of SAFETY and this section before attempting any procedure. Pay particular attention to Notices, Cautions, Warnings and Dangers.

Coasting



Do not allow the vehicle to coast at above recommended speeds. Control vehicle speed with the brake.

The vehicle has a braking feature (pedal-up) that decreases the speed when the accelerator pedal is released. The feature continues to decrease the speed until the vehicle stops. Press the brake pedal if you need to decrease speed or stop the vehicle quickly.

Read all of SAFETY and this section before attempting any procedure. Pay particular attention to Notices, Cautions, Warnings and Dangers.

MAINTENANCE

VEHICLE CLEANING AND CARE

WARNING

Read and understand all instructions supplied by the manufacturer of the pressure washer before use.

CAUTION

When you clean the outside of the vehicle with a pressure washer, do not use more than 700-psi pressure. Keep a minimum distance of 12 inches from the spray nozzle to the painted surface. Do not clean the plastic parts with abrasive solvents.

Make sure you use correct methods and cleaning materials to prevent risk of damage to the outside of the vehicle. The use of more than 700-psi water pressure can cause injury to anyone in the area or damage to vehicle.

Clean the windshield with water and a clean cloth. Remove small scratches with a plastic polish or Plexus[®] plastic cleaner, available from the service parts department.

Apply a soap and water solution with a sponge or soft brush to clean the vinyl seats and plastic or rubber trim. Dry with a cloth.

Use a commercially available vinyl and rubber cleaner to remove oil, tar, asphalt, shoe polish, etc.

Wash the vehicle frequently with cool water and mild detergent to protect the painted surfaces.

Apply wax that is for clear coat automotive finishes to improve the appearance and protection of the painted surfaces. Do not apply wax to matte finish surfaces.

Materials used as fertilizers or for dust control can collect on the bottom of the vehicle. These materials will cause corrosion of components, unless cleaned with water. Clean areas where mud or dirt can collect. Loosen the sediment that is packed in closed areas to help with removal. Be careful not to damage the paint.

ENVIRONMENTAL CONCERNS

WARNING

As a responsible user, practice respect for all wildlife and their habitat. Respect private property and comply with all local laws and regulations governing the use of light duty utility vehicles.

Always be respectful of the environment.

Make sure you are permitted by property owners to operate the vehicle on their property.

Be careful of environmental hazards like steep slopes, tree branches, etc.

MAINTENANCE

Read all of SAFETY and this section before attempting any procedure. Pay particular attention to Notices, Cautions, Warnings and Dangers.

Battery Disposal

Return used batteries to the manufacturer or lead smelter for recycling purposes. For neutralized spills, put residue in acid-resistant containers with absorbent material, sand or earth and discard according to state and federal regulations for acid and lead compounds. Contact authorized environmental people for information about disposal.

LIFTING THE VEHICLE

You must lift the front, the rear or the entire vehicle for some service and maintenance operations.

WARNING

The vehicle is not stable during the lifting process.

Make sure the vehicle is on a hard and level surface.

Never get below a vehicle that is supported by a jack only.

Make sure a vehicle that is supported on jack stands is stable before you get below the vehicle.

Put wheel chocks in front and behind the wheels that remain on the ground.

Do not allow any person in or on the vehicle being lifted.

CAUTION

When you lift the vehicle, put the jacks and jack stands at the areas indicated only.

Tool List	Quantity	Tool List	Quantity
Floor Jack.....	1	Jack Stands.....	4
Wheel Chocks	4		

Remove payload from vehicle before lifting. No person(s) should be in or on the vehicle while lifting.

How to lift the entire vehicle:

1. Install the wheel chocks in front and behind each front wheel.
2. Put the jack below the center of the rear frame crossmember.
3. Lift the vehicle enough to put jack stands below the outer ends of the rear axle as shown.
4. Lower the jack and test the stability of the vehicle on the two jack stands.
5. Put the jack at the center of the front axle.
6. Lift the vehicle enough to put two jack stands below the front frame crossmember as shown.
7. Lower the jack and test the stability of the vehicle on all four jack stands.

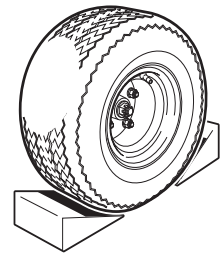

How to lift the rear of the vehicle only:

1. Put the wheel chocks in front and behind each front wheel.
2. Put the jack below the center of the rear frame crossmember.
3. Lift the vehicle enough to put a jack stand below the outer ends of the rear axle as shown.
4. Lower the jack and test the stability of the vehicle on the two jack stands.

How to lift the front of the vehicle only:

1. Put the wheel chocks in front and behind each rear wheel.

Read all of SAFETY and this section before attempting any procedure. Pay particular attention to Notices, Cautions, Warnings and Dangers.

2. Put the jack at the center of the front axle.
3. Lift the vehicle enough to put two jack stands below the front frame crossmember as shown.
4. Lower the jack and test the stability of the vehicle on the two jack stands.

Lower the vehicle:

1. Lift the vehicle enough to remove the jack stands.
2. Carefully lower the vehicle to the ground with the jack.

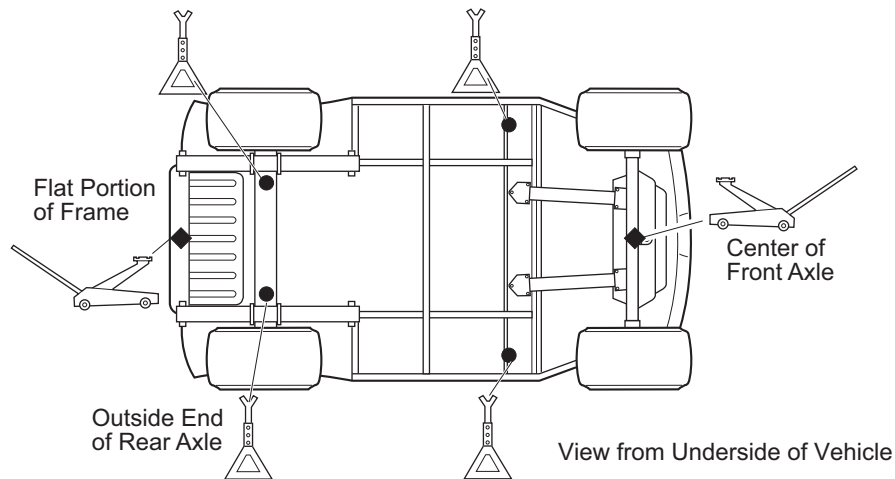

WHEELS AND TIRES

Recommended tire inflation pressure: 18-22 psi

⚠ WARNING

To decrease the risk of tire explosion, do not exceed the tire inflation pressure rating on the tire sidewall.

To decrease the risk of tire explosion, inflate small amounts of air into the tire at intervals to seat beads. Because of the low volume of the small tires, over inflation can occur in seconds. Never exceed the tire inflation pressure rating on the tire sidewall when seating a bead. Protect the face and eyes when you remove a valve core.

When you remove the wheels, use only sockets made for impact wrenches to decrease the risk of injury by a broken socket.

Do not use tires with low rated pressure. Do not use tires that have a recommended tire inflation pressure less than the tire inflation pressure recommended in the owner's guide.

Do not over inflate the tires. Excess pressure can cause the tire to separate from the wheel or cause a tire explosion.

MAINTENANCE

Read all of SAFETY and this section before attempting any procedure. Pay particular attention to Notices, Cautions, Warnings and Dangers.

Tire Repair

Tool List	Quantity	Tool List	Quantity
Lug Wrench, 3/4"	1	Impact Socket, 3/4"	1
Impact Wrench	1	Torque Wrench, ft. lbs.	1

Use caution when you inflate the tires. Because of the low volume of the small tires, over inflation can occur in seconds. Over inflation can cause the tire to separate from the wheel or cause a tire explosion.

The general recommended tire inflation pressure is 18-22 psi, but know that tire inflation pressure can change according to the condition of the terrain.

For outdoor applications with primary use on areas with grass, consider the following:

- Slightly higher tire inflation pressure is suitable on hard turf
- A lower pressure decreases the risk of tires cutting into a soft turf

For hard surfaces or pavement, tire inflation pressure must be in the higher allowed range, but not more than recommended on the tire sidewall.

All four tires must have the same pressure for best control qualities. Always install the valve stem cap after you check or inflate the tires.

The vehicle has low-pressure tubeless tires, installed on one-piece rims.

Use a tire plug to repair small holes in the tread part of the tire. For large holes and cuts, replace the tire.

NOTICE

Tire plug tools and plugs are available at automotive outlets. The tires do not have to be removed from the wheel to install the tire plugs.

If the tire is flat, remove the wheel and inflate the tire to the recommended maximum pressure for the tire. Submerge the tire in water to find the leak and mark with chalk. Install the tire plug according to manufacturers instructions.

Wheel Installation

CAUTION

To decrease the risk of component damage, do not tighten lug nuts to more than 85 ft. lbs. (115 Nm) torque.

NOTICE

Always follow the cross-sequence pattern when you install the lug nuts to make sure the wheel is evenly seated against the hub.

With the valve stem to the outside of the wheel, install the wheel on the hub with lug nuts.

Tighten the lug nuts (1) with your fingers in the cross-sequence pattern shown.

Tighten the lug nuts to 50 to 85 ft. lbs. (68 to 115 Nm) torque in 20 ft. lbs. (27 Nm) increments.

Continue to follow the cross-sequence pattern until the correct torque is reached.

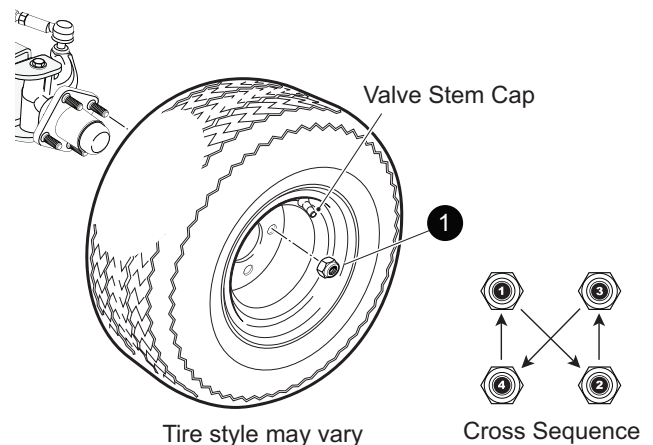

Read all of SAFETY and this section before attempting any procedure. Pay particular attention to Notices, Cautions, Warnings and Dangers.

LIGHT BULB REPLACEMENT



To decrease the risk of premature bulb failure, do not allow your fingers to contact new bulbs. Use clean, dry paper or paper towels to touch the glass part of the bulb.

Headlight

Rotate the bulb socket a quarter turn to the left to unlock. Remove the bulb and socket. Install new bulb and rotate the socket a quarter turn to the right to secure.

Replacement bulbs are available from a local Distributor, an authorized Branch or the Service Parts Department.

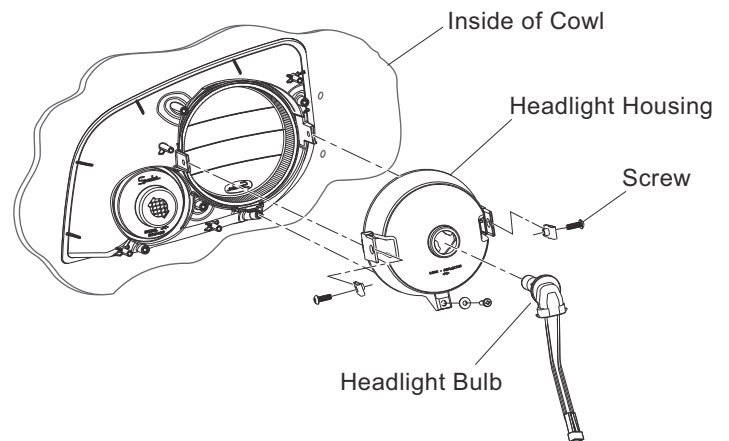

Taillight

To replace the taillight and brake light bulb, lift the rubber bezel from around the edge of the taillight and remove the lens. Install the replacement bulb and replace the lens.

Replacement bulbs are available from a local Distributor, an authorized Branch or the Service Parts Department.

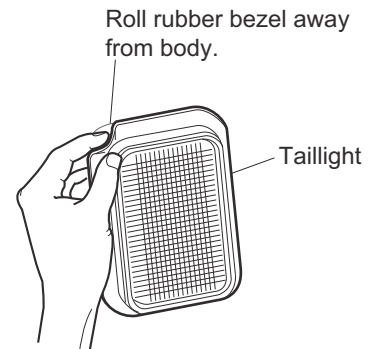

FUSE REPLACEMENT

The fuse block is found below the driver seat. Lift the seat bottom to access the fuses.

Remove the old fuse and replace with a new fuse of the same type and size.

Fuses are available from a local Distributor, an authorized Branch or the Service Parts Department.

MAINTENANCE

Read all of SAFETY and this section before attempting any procedure. Pay particular attention to Notices, Cautions, Warnings and Dangers.

TRANSPORTING VEHICLE

Towing

WARNING

Do not ride or allow other people on the vehicle being towed.

Do not try to tow the vehicle with ropes, chains or any device different from a tow bar approved by the factory.

Do not tow the vehicle on highways.

Do not tow the vehicle at speeds more than 12 mph (19 kph).

Before towing the vehicle, put the run/tow switch in the TOW position.

Hauling

WARNING

Make sure you secure the vehicle and all items before you move a vehicle on a trailer.

Do not allow any people on a vehicle being moved on a trailer.

Remove the windshield before you move a vehicle on a trailer.

Maximum speed with sun top installed is 50 mph (80 kph).

If you move the vehicle on a trailer at highway speeds, the sun top must be removed and the seat bottom secured.

When you move the vehicle on a trailer below highway speeds, check for tight hardware and cracks in sun top at the mounting points.

The rated capacity of the trailer or truck must be more than the weight of the vehicle and load plus 1000 lbs. (454 kg). See GENERAL SPECIFICATIONS for the weight of the vehicle.

Secure the vehicle to the trailer with ratchet tie downs.

SERVICE AND MAINTENANCE

WARNING

Read all notices, cautions and warnings in this manual before you do any type of service operations.

The drive wheels must be lifted and supported on jack stands before you do any service to the powertrain when the motor is in operation.

To decrease the risk of motor damage, do not operate the vehicle at full throttle for more than 5 seconds with the drive wheels lifted off the ground.

Read all of SAFETY and this section before attempting any procedure. Pay particular attention to Notices, Cautions, Warnings and Dangers.

Disconnect the negative battery terminal before you service the vehicle to prevent accidental operation.



Wear eye protection when you service the vehicle. Be careful when you do work around batteries, use solvents or compressed air.

To decrease the risk of electrical arc, which can cause a battery explosion, disable all electrical loads from the battery before you remove the battery wires.

Use wrenches with insulation to decrease the risk of a short-circuit if a wrench falls across the battery terminals. A battery short-circuit can cause an explosion.

The electrolyte in a battery is an acid solution which can cause burns to the skin and eyes. Completely clean all electrolyte spills that contact the body and eyes with clear water. Contact a physician immediately.

Neutralize electrolyte spills with a solution of 2 teaspoons (10 ml) sodium bicarbonate (baking soda) mixed in 1 quart (1 liter) of water. Clean with water.

Be careful when you use the aerosol containers near battery terminals. Use a metal container that has insulation to prevent an explosion.

The vehicle owner and service technician must carefully follow the procedures recommended in this manual. The preventative maintenance, applied at recommended intervals, keeps the vehicle dependable and decreases costs for repairs. Refer to the Periodic Service Schedule for service and intervals. Refer to Lubrication Points for correct lubrication locations.



CAUTION

To decrease the risk of damage to the controller or motor, move the run/tow switch to the TOW position before you tow the vehicle.

Before you disconnect or connect a battery or any other wires, move the run/tow switch to the TOW position.

After you connect a battery or any other wires, wait a minimum of 30 seconds before you move the switch to the RUN position.

ROUTINE MAINTENANCE



CAUTION

To increase the life of a vehicle that is used in rough conditions, some maintenance must be done more often than recommended in the Periodic Service Schedule. For example: high or low temperatures, high dust and dirt conditions, high use with maximum load.

To access the powertrain for normal maintenance, lift or remove the seat and remove the rear access panel. For major repairs, refer to the applicable Technician's Repair and Service Manual.

Some service procedures make it necessary to lift the vehicle. Refer to LIFTING THE VEHICLE for correct lift procedure and safety information.

TIRE INSPECTION

Inspect the tire condition according to the Periodic Service Schedule. Tire inflation pressures must be checked when the tires are cool. Always install the valve dust cap after you check or inflate the tires.

MAINTENANCE

Read all of SAFETY and this section before attempting any procedure. Pay particular attention to Notices, Cautions, Warnings and Dangers.

BRAKES

WARNING

Always inspect the pedal travel before you operate a vehicle to confirm some brake function is found.

Make sure you do all brake tests in a safe location with regard to the safety of all personnel.

NOTICE

A subtle loss of performance can occur over time; therefore, it is important to establish the standard with a new vehicle.

The Periodic Brake Performance Test should be performed regularly as an evaluation of braking system performance. It is useful as a method of identifying subtle loss of performance over time.

Periodic Brake Test

This test compares the brake performance of the vehicle to the brake performance of new or 'known to be good' vehicles or to an established acceptable stopping distance. Actual stopping distances are influenced by weather conditions, terrain, road surface condition, actual vehicle weight (accessories installed) and vehicle speed. No specific braking distance can be reliably specified. The test is conducted by latching the park brake to eliminate different pedal pressures and to include the affects of linkage mis-adjustment.

Establish the acceptable stopping distance by testing a new or 'known to be good' vehicle and recording the stopping location or stopping distance. Several vehicles should be tested when new and the range of stopping locations or distances recorded.

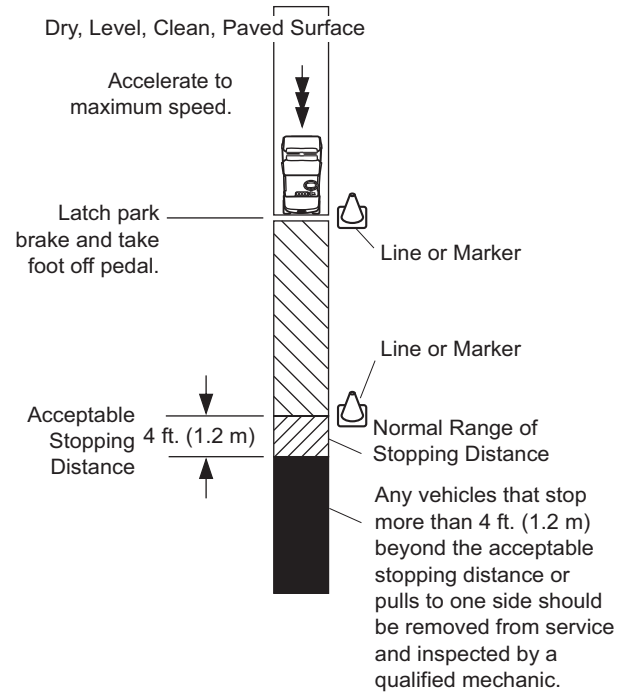

NOTICE

Over time, a subtle loss of performance may occur; therefore, it is important to establish the standard with a new vehicle.

Drive the vehicle at maximum speed on a flat, dry, clean, paved surface.

Quickly press the brake pedal to lock the parking brake at the line or marker in the test area and remove foot from pedal. The vehicle must stop fast. The wheel brakes may or may not lock.

Observe the vehicle stopping location or measure the vehicle stopping distance from the point at which the brakes were locked. The vehicle must stop within the 'normal' range of stopping distances. If the vehicle stops more than 4 ft. (1.2 m) beyond the acceptable stopping distance or pulls to one side, the vehicle has failed the test and must be tested again.

If the vehicle fails the second test, it must **immediately** be removed from service. The vehicle **must** be inspected by a qualified mechanic who should refer to the TROUBLESHOOTING or FAULT DIAGNOSIS section in the Technician's Repair and Service Manual.

Read all of SAFETY and this section before attempting any procedure. Pay particular attention to Notices, Cautions, Warnings and Dangers.

REAR AXLE

The only maintenance necessary for the first five years is the inspection of the rear axle for lubricant leakage. Unless leakage is visible, the lubricant needs to be replaced after five years. Refer to the Service and Repair Manual for the fluid replacement procedure.

Checking the Lubricant Level

Clean the area around the check/fill plug and remove the plug. The correct lubricant level is just below the bottom of the threaded hole. If lubricant is low, add lubricant as required. Add lubricant (30 WT engine oil) slowly until lubricant starts to seep from the hole. Install the check/fill plug. In the event that the lubricant is to be replaced, the oil pan must be removed or the oil siphoned through the check/fill hole.

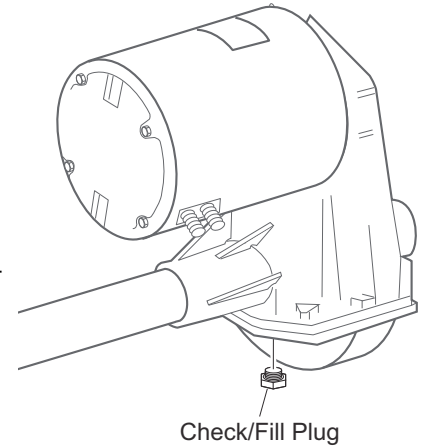

LUBRICATION

⚠ CAUTION

Do not use more than three (3) pumps of grease in any grease fitting at any one time. Excess grease may cause grease seals to fail or grease migration into areas that could damage components.

Putting more than three pumps of grease in a grease fitting could damage grease seals and cause premature bearing failure.

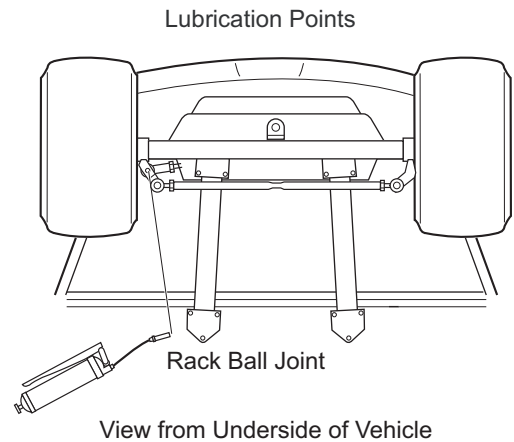

CAPACITIES AND REPLACEMENT PARTS

Rear Axle Oil	12 oz (1.2 liters) 30 WT Engine Oil
Fuse (15 amp)	P/N 18392-G1
Headlight Bulb	P/N 619100
Turn Signal Bulb	P/N 619102
Tail Light Bulb	P/N 21759-G1







MAINTENANCE

Read all of SAFETY and this section before attempting any procedure. Pay particular attention to Notices, Cautions, Warnings and Dangers.

HARDWARE

Normally, three classes of standard hardware and three classes of metric hardware are used in the vehicle. Grade 5 hardware is identified by the three marks on the hexagonal head; grade 8 hardware is identified by six marks on the head; grade 2 hardware is not marked. The class specification is marked on metric hardware.

Inspect the vehicle for loose fasteners periodically. The fasteners must be tightened carefully and according to the Torque Specifications table or as specified in the Repair and Service Manual.

ALL TORQUE FIGURES ARE IN FT. LBS. (Nm)										
Unless otherwise noted in text, tighten all hardware in accordance with this chart.										
This chart specifies 'lubricated' torque figures. Fasteners that are plated or lubricated when installed are considered 'wet' and require approximately 80% of the torque required for 'dry' fasteners.										
BOLT SIZE	1/4"	5/16"	3/8"	7/16"	1/2"	9/16"	5/8"	3/4"	7/8"	1"
Grade 2 	4 (5)	8 (11)	15 (20)	24 (33)	35 (47)	55 (75)	75 (102)	130 (176)	125 (169)	190 (258)
Grade 5 	6 (8)	13 (18)	23 (31)	35 (47)	55 (75)	80 (108)	110 (149)	200 (271)	320 (434)	480 (651)
Grade 8 	6 (8)	18 (24)	35 (47)	55 (75)	80 (108)	110 (149)	170 (230)	280 (380)	460 (624)	680 (922)
BOLT SIZE	M4	M5	M6	M8	M10	M12	M14			
Class 5.8 (Grade 2) 	1 (2)	2 (3)	4 (6)	10 (14)	20 (27)	35 (47)	55 (76.4)			
Class 8.8 (Grade 5) 	2 (3)	4 (6)	7 (10)	18 (24)	35 (47)	61 (83)	97 (131)			
Class 10.9 (Grade 8) 	3 (4)	6 (8)	10 (14)	25 (34)	49 (66)	86 (117)	136 (184)			

Torque Specifications and Bolt Grades

Read all of SAFETY and this section before attempting any procedure. Pay particular attention to Notices, Cautions, Warnings and Dangers.

BATTERY CHARGING AND MAINTENANCE

Safety

Always obey the following warnings when working on or near batteries.

WARNING

To prevent the risk of battery explosion, keep all flammable materials, open flames or sparks away from the batteries.

Hydrogen gas is made as batteries are charged. Do not charge batteries without good ventilation. A 4% concentration of hydrogen gas is explosive.

Make sure that the key switch is in the OFF position and all electrical accessories are off before you start to work on the vehicle.

Turn off all accessories before disconnecting from the battery terminal.

SAFETY FIRST



**BEND KNEES
WHEN
LIFTING**

Use safe procedures to move the batteries. Always lift the battery with a commercially available battery lifting device.

Do not tilt the batteries during removal or installation. An electrolyte spill can cause burns and damage.

The electrolyte in a storage battery is an acid solution which can cause burns to the skin and eyes. Treat all electrolyte spills to the body and eyes with extended flushing with clear water. Contact a physician immediately.

Always wear a safety shield or approved safety goggles when you add water or charge the batteries.

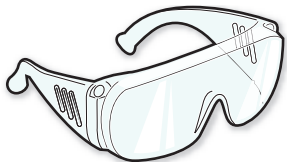

Neutralize electrolyte spills with a solution of 2 teaspoons (10 ml) sodium bicarbonate (baking soda) mixed in 1 quart (1 liter) of water. Clean with water.

If you fill the batteries with electrolyte above the maximum level, you can cause an electrolyte spill during the charge cycle. An electrolyte spill can cause damage to the vehicle and storage facility.

Be careful when you use aerosol containers near the battery terminals. Use a container with insulation to prevent an explosion.

Use wrenches with insulation to decrease the risk of a short-circuit if a wrench falls across the battery terminals. A battery short-circuit can cause an explosion.

Battery Disposal

Lead-acid batteries are recyclable. Return used batteries to distributor, manufacturer or lead smelter for recycling. For neutralized spills, put residue in acid-resistant containers with absorbent material, sand or earth and discard according to state and federal regulations for acid and lead compounds. Contact state environmental officials for disposal information.

Battery

A battery is described as two dissimilar metals immersed in an acid. If the acid is absent or if the metals are not dissimilar, a battery has not been created. The batteries in this vehicle are lead acid.

MAINTENANCE

Read all of SAFETY and this section before attempting any procedure. Pay particular attention to Notices, Cautions, Warnings and Dangers.

A battery does not store electricity, but it can produce electricity as the result of a chemical reaction which releases stored chemical energy in the form of electrical energy. The chemical reaction occurs faster in warm conditions and slower in cold conditions. Temperature is important when conducting tests on a battery and test results must be corrected to adjust for temperature differences.

An older battery can perform adequately except that its capacity is decreased. Capacity describes the time that a battery can continue to supply its design amperes from a full charge.

A battery has a maximum life. Good maintenance maximizes the available life and decreases the conditions that can reduce the life of the battery.

Battery Maintenance

Tool List	Quantity	Tool List	Quantity
Insulated Wrench, 9/16"	1	Battery Carrier	1
Hydrometer.....	1	Battery Maintenance Kit P/N 25587-G01	1
Battery Protective Spray.....	1	Socket, 9/16"	1
Torque Wrench	1		

At Each Charging Cycle

- Before you charge the batteries, inspect the plug of the battery charger and vehicle receptacle housing for dirt or other particles.
- Charge the batteries after each use.

Monthly

- Inspect all wires for wear, loose connections, corrosion or damage of insulation.
- Make sure that the electrolyte level is correct and add clean water as required.
- Clean the batteries and wire connections.
- Apply battery protectant to the battery terminals.

Electrolyte Level and Water

The correct level of the electrolyte is 1/2" (13 mm) above the plates in each cell.

This level will leave approximately 1/4" - 3/8" (6 - 10 mm) of space between the electrolyte and the vent tube.

The electrolyte level is important because any part of the plates open to air will be damaged.

Do not overfill with water. Too much water pushes the electrolyte from the battery by release of gas and a decrease in volume of the electrolyte.



CAUTION

DO NOT overfill batteries. The charge cycle will expel electrolyte and cause component damage.

Read all of SAFETY and this section before attempting any procedure. Pay particular attention to Notices, Cautions, Warnings and Dangers.

A battery being charged will 'gas' with most gassing occurring at the end of the charging cycle. This gas is hydrogen which is lighter than air. Water and sulphuric acid droplets will be carried out of the battery vents by the hydrogen gas, however, this loss is minimum. If the electrolyte level is high, the electrolyte will block the vent tube and the gas will push it out the vent tube and battery cap. The water will dry but the sulphuric acid will stay and damage the vehicle components and the storage facility floor. Sulphuric acid loss will weaken the amount of acid within the electrolyte and decrease the life of the battery.

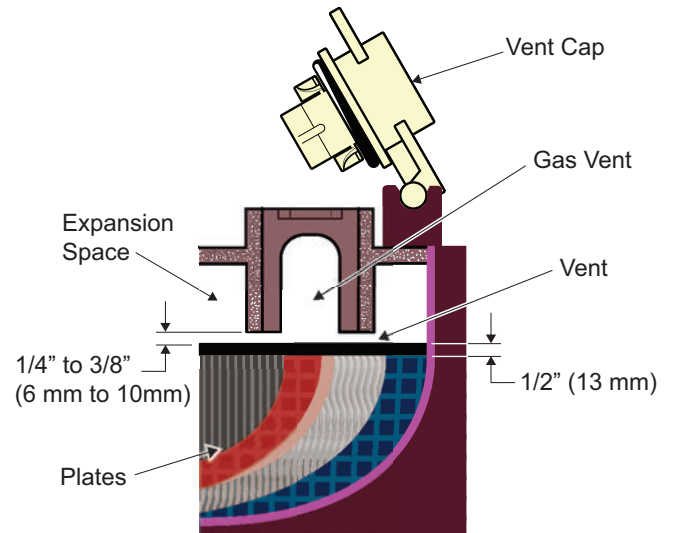

Electrolyte level should be at least 1/2" (13mm) above the plates and 1/4" to 3/8" (6 to 10 mm) below vent
Correct Electrolyte Level

Over the life of the battery, a large amount of water is used. The water used must be clean and without contamination. Water that is not clean decreases the life of the battery by reducing the chemical reaction. Use distilled water or filtered water only. Test water that is not distilled water and filter if needed. Refer to the water purity table for requirements.

Impurity	Parts Per Million
Color	Clear
Suspended	Trace
Total Solids	100
Calcium & Magnesium Oxides	40
Iron	5
Ammonia	8
Organic & Volatile Matter	50
Nitrites	5
Nitrates	10
Chloride	5

Water Purity Table

Hand held watering devices available at an automotive parts store, or automatic watering devices like the one included in the E-Z-GO Battery Maintenance Kit (P/N 25587-G01) can be used with an approved water supply. These watering devices are accurate, easy to use and allow for fast fill. They also keep the correct electrolyte level within the battery cells.

Watering gun similar to the type included in the E-Z-GO Battery Maintenance Kit

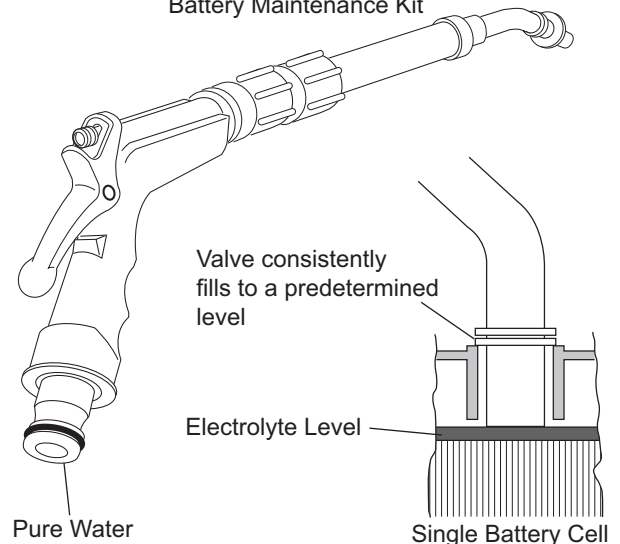

NOTICE

The watering device must only be used if the electrolyte level is less than 1/2" (13 mm) above top of plates.

MAINTENANCE

Read all of SAFETY and this section before attempting any procedure. Pay particular attention to Notices, Cautions, Warnings and Dangers.

⚠ WARNING

The electrolyte in a battery is an acid solution which can cause severe burns to the skin and eyes. Clean all electrolyte spills to the body and eyes with clear water. Contact a physician immediately.



To clean an electrolyte spill, use a solution of 2 teaspoons (10 ml) sodium bicarbonate (baking soda) mixed with 1 quart (1 liter) of water.

Always wear a safety shield or approved safety goggles when you add water or charge the batteries.

Battery Cleaning

⚠ CAUTION

To prevent battery damage, make sure you correctly install all battery caps.

To decrease the risk of damage to vehicle or floor, neutralize acid before you spray the battery with water.

To decrease the risk of damage to the electrical components while cleaning, do not use a pressure washer.

Clean the batteries according to the Periodic Service Schedule.

When you clean the battery cases and terminals, do not use a water hose without neutralizing any acid deposits first. The water hose moves the acid from the top of the batteries to another area of the vehicle or storage facility, where it can cause damage. After spraying the batteries, a conductive residue remains on the batteries and contribute to the discharge of the batteries

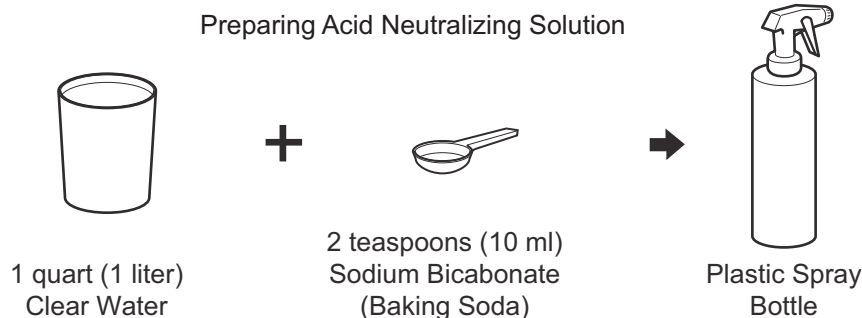

The correct cleaning method is to spray the top and sides of the batteries with a solution of baking soda and water. Apply this solution with a plastic spray bottle. The solution is 2 teaspoons (10 ml) sodium bicarbonate (baking soda) mixed with 1 quart (1 liter) of water. Spray the solution on all metal components near the batteries also.

Allow the solution to set a minimum of three minutes. Use a soft bristle brush or cloth to clean the top of each battery to remove residue that can cause the discharge of the battery. Clean the area with low pressure clear water.

⚠ WARNING

Be careful when you use aerosol containers near the battery terminals. Use a container with insulation to prevent an explosion.

Clean one time a month or more often in harsh conditions. After the batteries are clean and dry, apply a commercially available protectant to the terminals.

Read all of SAFETY and this section before attempting any procedure. Pay particular attention to Notices, Cautions, Warnings and Dangers.

Battery Replacement

⚠ CAUTION

Before you disconnect or connect a battery or any other wires, move the run/tow switch to TOW position.

After you connect a battery or any other wires, wait a minimum of 30 seconds before you move the run/tow switch to the RUN position.

Remove the battery hold downs and cables. Remove the batteries with a commercially available lifting device.

If the batteries are cleaned and acid in the battery rack area is neutralized as recommended, no corrosion to the battery racks or surrounding area should be found. Any corrosion found must be removed with a putty knife and a wire brush. The area must be washed with a solution of sodium bicarbonate (baking soda) and water and dried before primer and corrosion resistant paint is applied.

Put the batteries in the battery racks and tighten the hold downs to 45 - 55 in. lbs. (5 - 6 Nm) torque. The hold downs must be tight enough to prevent movement of the battery, but not tight enough to cause distortion of the battery cases.

Inspect all wires and terminals. Clean corrosion from the battery terminals or the wire terminals with a solution of sodium bicarbonate (baking soda) and soft brush if needed.

⚠ WARNING

Be careful when you use aerosol containers near the battery terminals. Use a container with insulation to prevent an explosion.

Make sure you connect the battery wires as shown.

Tighten the battery post hardware to 90 - 100 in. lbs. (6 - 8 Nm) torque. Do not over-tighten the terminal stud nut, this will cause a "mushroom" effect on the battery post which will prevent the terminal nut from being correctly tightened.

Protect the battery terminals and battery wire terminals with a commercially available coating.

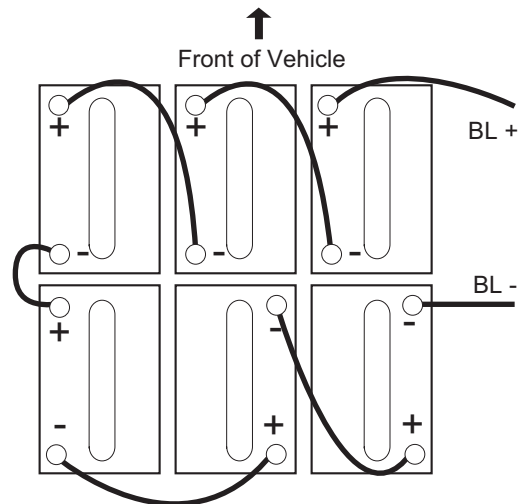

Prolonged Storage

⚠ CAUTION

Disconnect the battery charger, controller and other electronic devices for extended storage. All connected electronic components cause the discharge of batteries.

NOTICE

Put the run/tow switch in the TOW position for extended storage of the vehicle to prevent draining of the batteries.

MAINTENANCE

Read all of SAFETY and this section before attempting any procedure. Pay particular attention to Notices, Cautions, Warnings and Dangers.

During storage, the batteries need attention to keep them maintained and prevent discharge. In high temperatures the chemical reaction is faster, while low temperatures cause the chemical reaction to slow. A vehicle that is stored at 90° F (32° C) will lose .002 of specific gravity each day. If a completely charged battery has a specific gravity of 1.275, and the battery is not used, it will become partially discharged. When it reaches 1.240, which it will do in less than 20 days, it must be charged again. If a battery stays in a discharged state, sulfating occurs on and within the plates. This condition is not reversible and will cause permanent damage to the battery. To prevent damage, the battery must be charged again. Use a hydrometer to find the specific gravity and the state of charge of a battery.

In winter conditions, the battery must be completely charged to prevent the risk of freezing. A completely charged battery will not freeze in temperatures above -75° F (-60° C). Although the chemical reaction is decreased in cold temperatures, the battery must be stored completely charged, and disconnected from circuits that can discharge the battery. The controller must be disconnected from the batteries by setting the run/tow switch to the TOW position.

For portable chargers, disconnect the charger plug from the vehicle receptacle.

For on-board chargers, disconnect the charging harness from the batteries.

The batteries must be cleaned and all deposits neutralized and removed from the battery case to prevent self discharge. The batteries must be tested or charged again at 30 day minimum intervals.

Battery Charging

The battery charger is designed to completely charge the battery set. If the batteries are severely deep cycled, some automatic battery chargers contain an electronic module that will not activate and the battery charger will not operate. Automatic chargers determine the correct length of charge to the battery set and turns off when the batteries are charged. Always refer to the instructions of the charger used.

CAUTION

Do not overfill batteries. The charge cycle will expel electrolyte and cause component damage.

Before charging, the following must be observed:

- The electrolyte level in all cells must be at the recommended level and above the plates.
- The charging must occur in an area with good ventilation to remove hydrogen gas that is made during the charge cycle. A minimum of five air replacements for each hour is recommended.
- The charger connector components must be in good condition and free from dirt and particles.
- The charger connector must be completely installed in the vehicle receptacle.
- The charger connector and cord set must be protected from damage. The charger connector and cord set must be used in an area where it is not possible for personnel to run over or trip over the cord set.
- The charger automatically turns off during the connect and disconnect cycle so no electrical arc is generated at the DC plug and receptacle contacts.

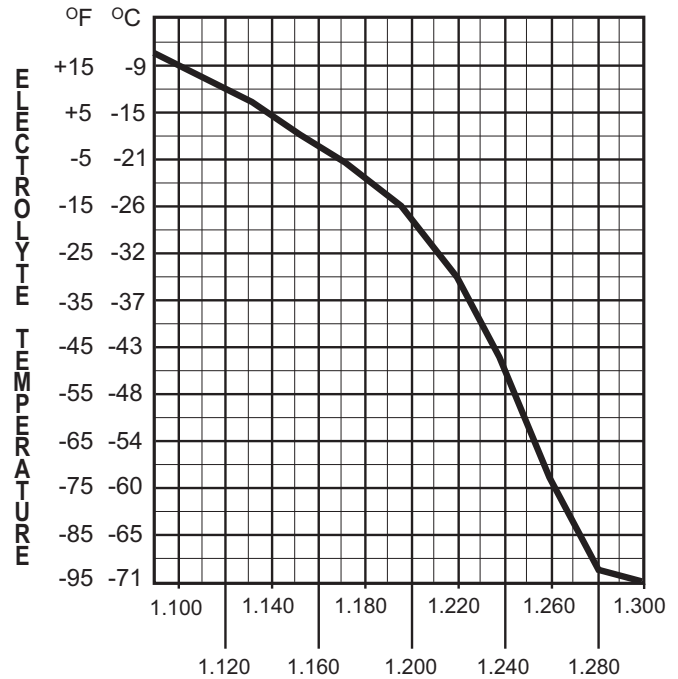

SPECIFIC GRAVITY ELECTROLYTE FREEZING POINT

Read all of SAFETY and this section before attempting any procedure. Pay particular attention to Notices, Cautions, Warnings and Dangers.

AC Voltage

The battery charger output is directly related to the input voltage. If the vehicle receives an incomplete charge in a normally adequate time period, low AC voltage can be the cause. Consult an electrician if necessary.

Fault Diagnosis

Fault diagnosis is done for two reasons:

- A battery that performs poorly and is outside of the manufacturer's specification must be identified to replace it within the terms of the manufacturer's warranty. Different manufacturers have different requirements. Refer the battery manufacturer or the manufacturer's representative for specified requirements.
- Find the reason a vehicle does not perform adequately. Performance problems can cause a vehicle to run slowly or can not operate for the time needed.

A new battery must mature before it develops its maximum capacity. Maturing can take 100 or more charge and discharge cycles. After the maturing phase, the older a battery gets, the lower the capacity. The only method to find the capacity of a battery is a load test with a discharge machine. Refer to the discharge machine manufacturer instructions.

A hydrometer is used to identify a poorly performing battery in a set with a low specific gravity. When the particular cell or cells that are the problem are identified, the battery can be removed and replaced. The battery can not be restored. The individual battery should be replaced with a good battery of the same brand, type and approximate age.

Hydrometer

A hydrometer (P/N 50900-G1) is used to test the state of charge of a battery cell. This is performed by measuring the density of the electrolyte, which is accomplished by measuring the specific gravity of the electrolyte. The greater the concentration of sulfuric acid, the more dense the electrolyte becomes. The higher the density, the higher the state of charge.

WARNING

To prevent battery explosion, never insert a metal thermometer into a battery. Use a hydrometer with a built in thermometer that is designed for testing batteries.

Specific gravity is the measurement of a liquid that is compared to a baseline. The baseline is water which is assigned a base number of 1.000. The concentration of sulfuric acid to water in a new golf car battery is 1.280 which means that the electrolyte weighs 1.280 times the weight of the same volume of water. A fully charged battery will test at 1.275 - 1.280 while a discharged battery will read in the 1.140 range.

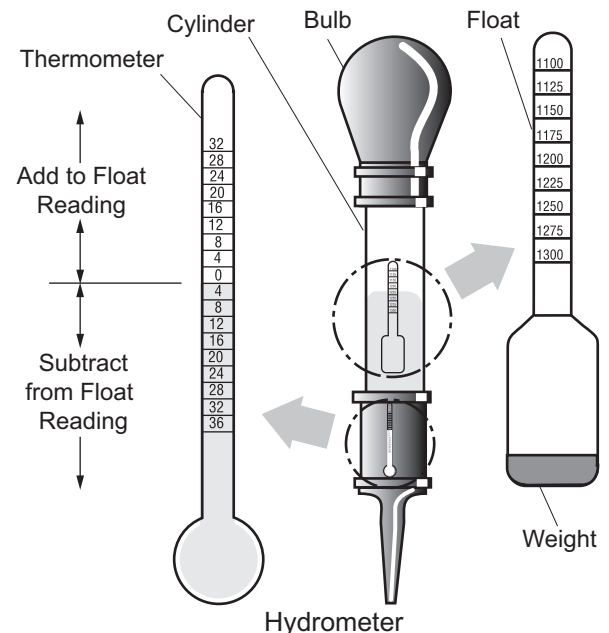

NOTICE

Do not perform a hydrometer test on a battery that has just been watered. The battery must go through at least one charge and discharge cycle in order to permit the water to adequately mix with the electrolyte.

The temperature of the electrolyte is important since the hydrometer reading must be corrected to 80° F (27° C). High quality hydrometers are equipped with an internal thermometer that will measure the temperature of the electrolyte and will include a conversion scale to correct the float reading. It is important to recognize that the electrolyte temperature is significantly different from the ambient temperature if the vehicle has been operated.

MAINTENANCE

Read all of SAFETY and this section before attempting any procedure. Pay particular attention to Notices, Cautions, Warnings and Dangers.

Using A Hydrometer

1. Draw electrolyte into the hydrometer and release it several times to permit the thermometer to adjust to the electrolyte temperature and note the reading. Examine the color of the electrolyte. A brown or gray coloration indicates a problem with the battery and is a sign that the battery is nearing the end of its life.
2. Draw the minimum quantity of electrolyte into the hydrometer to permit the float to float freely without contacting the top or bottom of the cylinder.
3. Hold the hydrometer in a vertical position at eye level and note the reading where the electrolyte meets the scale on the float.
4. Add or subtract four points (.004) to the reading for every 10° F (6° C) the electrolyte temperature is above or below 80° F (27° C). Adjust the reading to conform with the electrolyte temperature, e.g., if the reading indicates a specific gravity of 1.250 and the electrolyte temperature is 90° F (32° C), add four points (.004) to the 1.250 which gives a corrected reading of 1.254. Similarly if the temperature was 70° F (21° C), subtract four points (.004) from the 1.250 to give a corrected reading of 1.246.
5. Test each cell and note the readings (corrected to 80° F or 27° C). A variation of fifty points between any two cell readings (example 1.250 - 1.200) indicates a problem with the low reading cell(s).

As a battery ages the specific gravity of the electrolyte will decrease at full charge. This is not a reason to replace the battery providing all cells are within fifty points of each other.

Since the hydrometer test is in response to a vehicle exhibiting a performance problem, the vehicle should be recharged and the test repeated. If the results indicate a weak cell, the battery or batteries should be removed and replaced with a good battery of the same brand, type and approximate age.

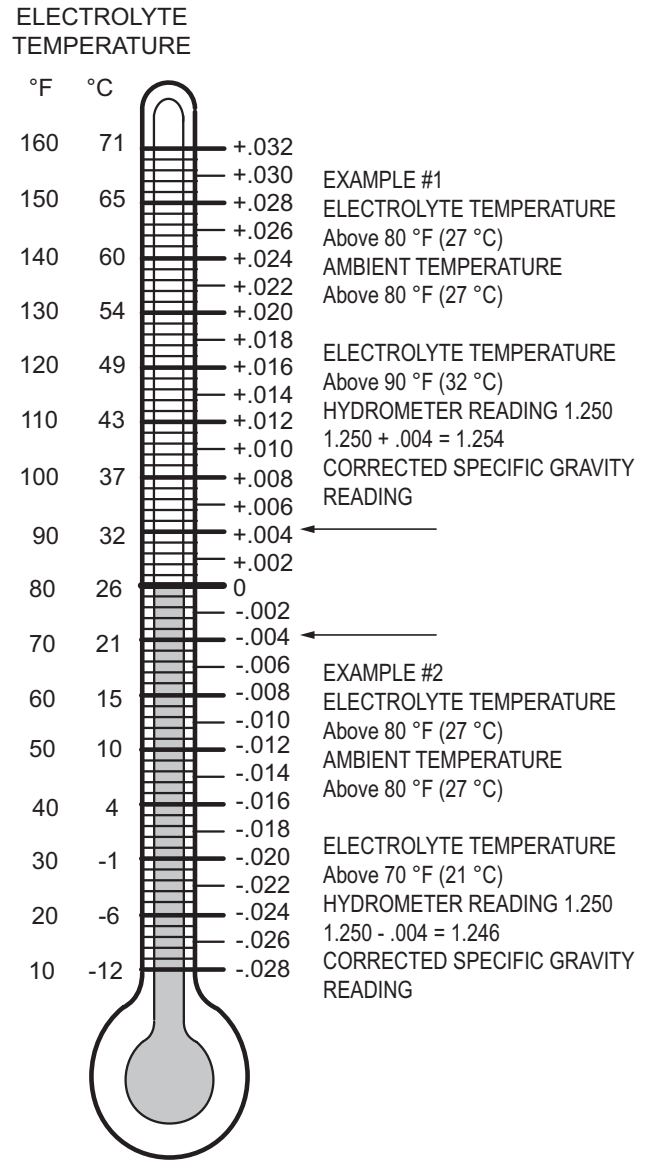

Hydrometer Temperature Correction

Battery Charger Maintenance

Connect the charger plug into the vehicle receptacle and wait for the relay to activate.

Move the plug back and forth in the receptacle. If the charger turns off, check the plug for a broken red wire in the DC cord

Read all of SAFETY and this section before attempting any procedure. Pay particular attention to Notices, Cautions, Warnings and Dangers.

Notes:

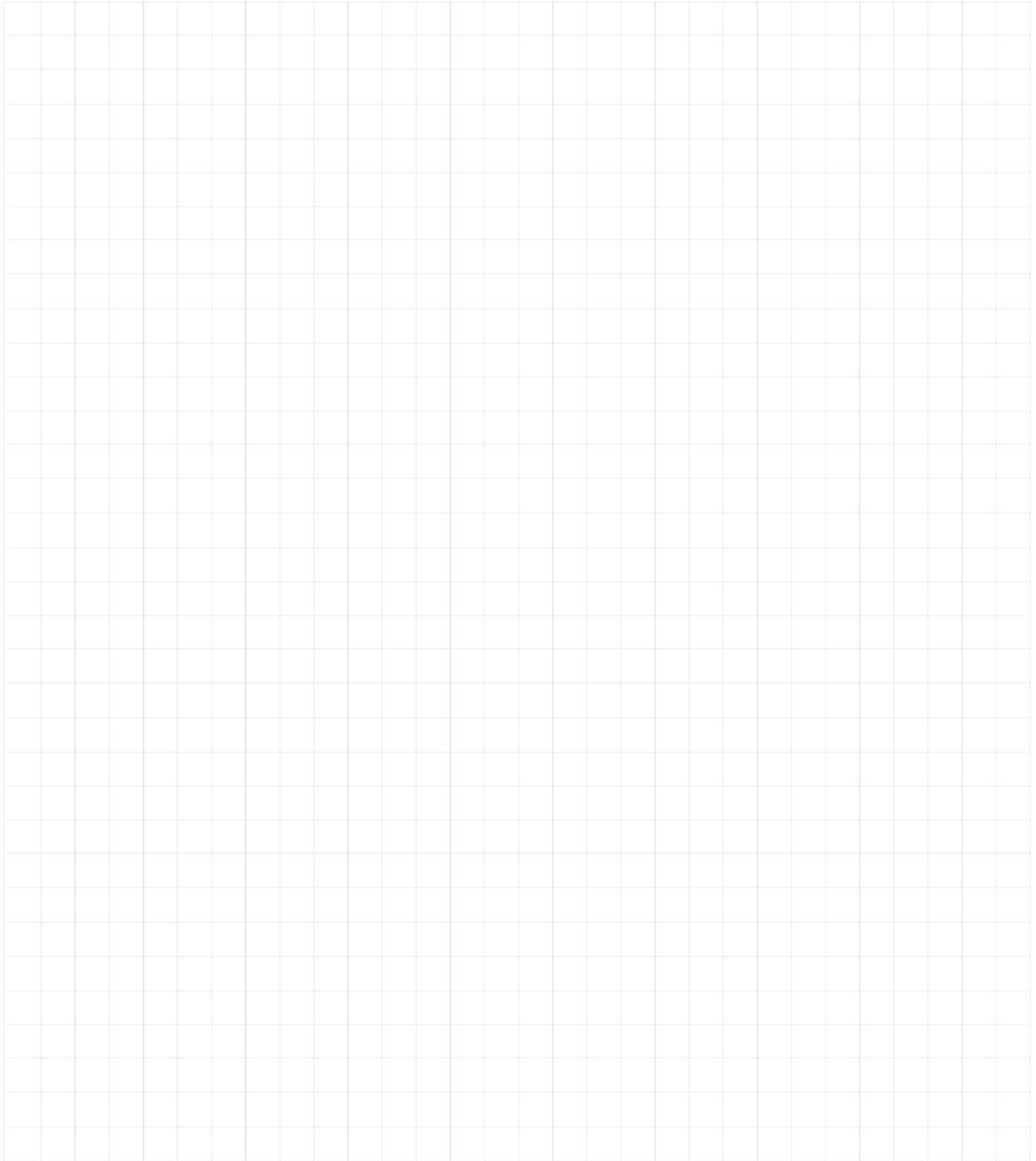
A large grid of graph paper for taking notes, consisting of 20 columns and 30 rows of small squares.

PERIODIC SERVICE SCHEDULE

Read all of SAFETY and this section before attempting any procedure. Pay particular attention to Notices, Cautions, Warnings and Dangers.

PERIODIC SERVICE SCHEDULE

PERIODIC SERVICE SCHEDULE

* - CHECK C&A - CHECK & ADJUST CL - CLEAN R - REPLACE

	Before each use DAILY	WEEKLY	20 hrs MONTHLY	50 hrs QUARTERLY	125 hrs SEMI-ANNUAL	250 - 300 hrs ANNUAL	5 YEARS
Tires - Check pressure and inspect condition of tires & rims.	*	*	*	*	*	*	
Hardware - Check for loose or missing.	*	*	*	*	*	*	
Reverse Warning Indicator	*	*	*	*	*	*	
Overall Vehicle Condition	*	*	*	*	*	*	
Battery Pack - Check state of charge, condition, loose terminals, corrosion, hold down & hardware.	*	*	CL	CL	CL	CL	
Batteries* - Check electrolyte level, fill if required.			*	*	*	*	
Brake Pedal - Check for smooth operation	*	*	*	*	*	*	
Parking Brake - Check for correct hold capability.	*	*	C&A	C&A	C&A	C&A	
Accelerator - Check for smooth operation.	*	*	*	*	*	*	
Charger / Receptacle - Inspect charger connector and receptacle.	*	*	*	*	*	*	
TrueCourse Technology (TCT) System - Test operation			*	*	*	*	
Brakes - Conduct brake performance test; adjust if required.			C&A	C&A	C&A	C&A	
Parking Brake - Conduct brake performance test; adjust if required.			C&A	C&A	C&A	C&A	
Controller - Check controller braking force for correct operation.			*	*	*	*	
Wiring - Inspect for loose connections, broken or missing insulation.			*	*	*	*	
Direction Selector - Inspect attachment and mechanism.			C&A	C&A	C&A	C&A	
Steering Assembly - Check for excess play, loose or missing hardware.			*	*	*	*	
Tie Rods - Check for excess play, bent rods, loose or missing hardware.			*	*	*	*	
Front Axle - Check for damage to axle, loose or missing hardware.				*	*	*	
Rear Axle - Check fluid level, oil leakage, noise, loose or missing hardware.			*	*	*	*	
Parking Brake - Inspect linkage rods, latch arm and catch bracket.				*	*	*	
Parking Brake - Lubricate with light oil. Do not lubricate cables or brake latch.				C&A	C&A	C&A	
Rear Axle - Drain & replace fluid.							R
Rear Suspension - Inspect for shock oil leakage, worn bushings, loose or missing hardware.				*	*	*	
Front Suspension - Inspect for strut oil leakage, excessive play in hubs or kingpins, worn bushings, loose or missing hardware.				*	*	*	
Front Wheel Alignment - Inspect for unusual tire wear.				C&A	C&A	C&A	
Steering Assembly - Inspect bellows and pinion seal for damage and leakage.					*	*	
Rack End Ball Joint - Check for noise and loose or missing hardware.					*	*	

* Use only distilled or purified water that is free from contaminants to fill batteries.

NOTE: Some maintenance items must be serviced more frequently on vehicles used under severe driving conditions.

NOTICE

Read the following warnings before operating vehicle:

WARNING

When you leave the vehicle, turn the key to the OFF position and remove the key from the vehicle.

Drive the vehicle only as fast as terrain and conditions allow. Consider the terrain and traffic conditions. Consider environmental conditions that change the terrain and your ability to control the vehicle.

Do not drive fast downhill. Sudden stops or change of direction can cause a loss of control. Use the brake to control the speed of the vehicle when you drive down a slope.

When possible, stay in approved areas and do not drive on steep slopes.

Always keep feet, legs, hands and arms inside vehicle.

Do not drive on rough terrain.

Before you drive in the reverse direction, make sure the area behind the vehicle is clear.

Make sure the direction selector is in the correct position before you press the accelerator pedal.

Decrease speed before and during turns.

Make sure you completely stop the vehicle before you move the direction selector.

See GENERAL SPECIFICATIONS for the vehicle load and seat capacity.

NOTICE

Read the following information and warnings before operating vehicle:

In any product, components will eventually fail to perform properly as the result of normal use, age, wear or abuse.

Normal use, age, wear or abuse can cause some components on the vehicle to fail. The manufacturer can not know all possible component failures or the methods that failures can occur. A vehicle in need of repair does not operate correctly and can be dangerous.

Be careful when you service the vehicle. Be aware of your safety and the safety of other people in the area. Some components are heavy, spring loaded, corrosive, explosive, can cause high amperage or get hot. Battery acid and hydrogen gas can cause injury. Do not put your hands, face, feet or body in a location that can expose them to injury if an unexpected situation occurs.

Always use the correct tools shown in the tool list and wear safety equipment.

WARNING

Remove all jewelry before you service the vehicle.

Do not allow loose clothing or hair to contact the moving parts.

Do not touch hot objects.

The drive wheels must be lifted and supported on jack stands before you do any service to the powertrain when the motor is in operation.



When you service the vehicle, always wear eye protection. Be careful when you do work around batteries or you use solvents or compressed air.

Use wrenches with insulation to decrease the risk of a short-circuit if a wrench falls across the battery terminals. A battery short-circuit can cause an explosion.

To prevent the risk of battery explosion, keep all flammable materials, open flames or sparks away from the batteries.

Hydrogen gas is made as batteries are charged. Do not charge batteries without good ventilation.



CUSHMAN™

E-Z-GO Division of Textron Inc.

1451 Marvin Griffin Road, Augusta, Georgia 30906-3852 USA

CONTACT US:

North America:

**Technical Assistance & Warranty
Service Parts**

Phone: 1-800-774-3946, FAX: 1-800-448-8124

Phone: 1-888-GETEZGO (1-888-438-3946), FAX: 1-800-752-6175

International:

Phone: 001-706-798-4311, FAX: 001-706-771-4609

Service Parts Manuals, as well as Repair and Service Manuals
are available from a local Distributor, an authorized Branch,
Genuine E-Z-GO Parts & Accessories Department or at www.shopezgo.com.

Copyrighted Material

This manual may not be reproduced in whole
or in part without the express permission of
E-Z-GO Division of Textron Inc.,
Technical Communications Department