



CUSHMAN®

OWNER'S MANUAL

Hauler 800

ELITE™
LITHIUM

10027431-A

 **WARNING**

Read and comply with all of the instructions and safety precautions in this manual and on all product labels. Failure to follow the safety precautions could result in serious injury or death.

California Proposition 65

 **WARNING**

Operating, servicing and maintaining a passenger vehicle or off-road vehicle can expose you to chemicals including phthalates and lead, which are known to the State of California to cause cancer and birth defects or other reproductive harm. To minimize exposure, wear gloves and wash your hands frequently when servicing your vehicle.

For more information go to www.P65Warnings.ca.gov/passenger-vehicle.

 **WARNING**

Never modify the vehicle in any way that will alter the weight distribution of the vehicle, decrease its stability or increase the speed beyond the manufacturer's specifications. Such modifications can cause serious personal injury or death. The manufacturer, Cushman, prohibits and disclaims responsibility for any such modifications or any other alteration which would adversely affect the safety of the vehicle.

OWNER'S GUIDE

48V ELECTRIC **HAULER 800 ELITE**

Starting MODEL YEAR 2022

CONTACT INFORMATION

Textron Specialized Vehicles, Inc.

1451 Marvin Griffin Road

Augusta, Georgia, USA 30906-3852

North America:

Technical Assistance & Warranty PHONE: 1-800-774-3946, FAX: 1-800-448-8124

Service Parts PHONE: 1-800-438-3946, FAX: 1-800-752-6175

International PHONE: 001-706-798-4311, FAX: 001-706-771-4609

cushmancomm@textron.com

WELCOME

Thank you for purchasing this vehicle. Before driving your new vehicle, read this owner's manual to familiarize yourself with safe driving practices, operation, features and controls.

This manual contains instructions for minor maintenance only. Information about major repairs can be found in the repair manual. Your dealer has thorough knowledge of your vehicle and wants your total satisfaction with your purchase. We recommend you return to your dealership for all of your service needs during, and after the warranty period.

Repair or replacement parts can be purchased from your dealer or through the manufacturer's parts and accessories department.

These are original instructions as defined by 2006/42/EC.

Textron Specialized Vehicles, Inc. maintains the right to change the design of the vehicle without responsibility to make the changes on units purchased before changes were made. The information in this manual can change without notice.

All information in this owner's manual is based on the latest product information at the time of publication. Due to constant improvements in the design and quality of production components, some discrepancies may be found between your vehicle and the information presented in this publication. The content in this publication is intended for reference use only. The manufacturer is not liable for omissions or inaccuracies. Any reprinting or reuse of the content in this publication, whether whole or in part, is expressly prohibited.

Printed in USA

INTRODUCTION

MANUFACTURER’S INTENDED USE 1

WARRANTY AND REGISTRATION 1

BATTERY PROLONGED STORAGE 1

 Storage Preparation 1

 Setting State of Charge (SOC) 2

 During Storage 2

 Extreme Low Temperature Storage 2

 Returning Vehicle to Service 2

BATTERY DISPOSAL 2

VEHICLE IDENTIFICATION NUMBERS 3

REPAIR AND PARTS MANUALS 3

SAFETY

SAFETY LABELS 5

 Operation (P/N 651654) 5

 Operation (P/N 664789) (If equipped with card holder) 6

 Bed Latch Warning (P/N 74099G01) 6

 Load Bed (P/N 74821G06) 6

 Pinch Warning (P/N 651671) 6

 Run/Tow Switch Operation (P/N 679115) 7

MAXIMUM CARGO LOAD / MAXIMUM WEIGHT CAPACITY 7

TIRE PRESSURE 7

OPERATOR SAFETY 7

 Unauthorized Operation 8

 Operating without Instruction 8

 Alcohol or Drugs 8

 Passenger 9

 Before Operating 9

 Load Operation 9

 Driving in Reverse 9

 Driving a Damaged Vehicle 9

 Driving at Maximum Speeds 9

 Driving on Pavement 9

 Driving on Public Roads 9

 Turning 9

 Driving Uphill 9

 Driving Downhill 10

 Stalling on a Hill 10

 Tires 10

 Slippery Terrain 10

BATTERY CHARGING 10

VEHICLE LIFTING 10

VEHICLE MODIFICATION 11

MAINTENANCE SAFETY 11

FEATURES AND CONTROLS

KEY SWITCH 13

TABLE OF CONTENTS

HEADLIGHT SWITCH	13
Halogen	13
LED (If Equipped)	13
ELECTRIC BED LIFT SWITCH (IF EQUIPPED)	13
STATE OF CHARGE METER	13
HORN	13
CUP HOLDER	13
12V OUTLET (IF EQUIPPED)	14
USB PORT (IF EQUIPPED)	14
HOUR METER (IF EQUIPPED)	14
STEERING WHEEL	14
TURN SIGNAL/HORN (IF EQUIPPED)	14
RUN/TOW SWITCH	14
BRAKE PEDALS	14
Brake Pedal	15
Parking Brake Pedal	15
ACCELERATOR PEDAL	15
DIRECTION SELECTOR	15
SEAT BOTTOM	15
GLOVE BOX / STORAGE COMPARTMENTS	15
TRUCK BED	16
CANOPY TOP AND WINDSHIELD	16

OPERATION

SAFETY	17
BEFORE INITIAL USE	17
PRE-RIDE INSPECTION	17
ENVIRONMENTAL AWARENESS	17
BATTERY CHARGER	18
PERFORMANCE FEATURES	18
Speed Control	18
Pedal-Up Braking	18
Walk-Away Feature	18
Anti-Roll Back Feature	19
Anti-Stall Feature	19
High Pedal Disable Feature	19
Diagnostic Mode Feature	19
STARTING AND STOPPING THE VEHICLE	19
Starting on a Hill	19
ACCELERATING	20
BRAKING	20
Coasting	20
DRIVING PROCEDURE	20
Coasting	20
DRIVING WITH A PASSENGER	21
SLIPPERY SURFACES	21
DRIVING UPHILL	21
TRAVERSING HILLSIDES	21

TABLE OF CONTENTS

DRIVING DOWNHILL	22
STALLING ON A HILL	22
DRIVING IN REVERSE	22
PARKING THE VEHICLE	22
HAULING CARGO	23
Maximum Cargo Load / Maximum Weight Capacity	23
TRUCK BED OPERATION	24
Load Bed (P/N 74821G06)	24
DUMPING THE TRUCK BED	24
Manual Bed Release Lever	24
Electric Lift (If Equipped)	24
TOWING	25
MAINTENANCE	
MAINTENANCE SAFETY	27
SCHEDULED MAINTENANCE	27
Severe Use Conditions	27
SCHEDULED MAINTENANCE CHART	28
RECOMMENDED LUBRICANTS AND FLUIDS	29
REPLACEMENT OF MAINTENANCE ITEMS	29
LIFTING THE VEHICLE	30
Lifting Front	30
Lifting Rear	30
Lowering Vehicle	30
VEHICLE CLEANING AND CARE	31
Washing the Vehicle	31
Polishing the Vehicle	31
TIRES	31
Tire Pressure	32
Tire Repair	32
Tire Replacement	32
WHEELS	32
Wheel Removal	32
Wheel Installation	33
LIGHTS	33
Halogen Headlight Bulb Replacement	33
LED Headlight Assembly Replacement	33
LED Taillight/Brake Light	33
FUSE REPLACEMENT	34
CONTROLLER SYSTEM TEST	34
REAR AXLE	34
Checking the Lubricant Level	34
LUBRICATION	34
BRAKES	35
Periodic Brake Test	35
LITHIUM-ION BATTERY PACK	36
BATTERY CHARGING AND MAINTENANCE	36
BATTERY CHARGING	37

TABLE OF CONTENTS

BATTERY PROLONGED STORAGE	37
Storage Preparation	37
BATTERY FAULT DIAGNOSIS	37
TRANSPORTING THE VEHICLE	38
Towing the Vehicle	38
Hauling the Vehicle	38

SPECIFICATIONS

VEHICLE SPECIFICATIONS	39
------------------------------	----

INTRODUCTION

The following symbols appear throughout this manual and on vehicle labels. Your safety is involved when these symbols are used, become familiar with their meanings before reading the manual.



DANGER

DANGER indicates a hazardous situation that, if not avoided, will result in death or serious injury.



WARNING

WARNING indicates a hazardous situation, if not avoided, could result in death or serious injury.



CAUTION

CAUTION indicates a hazardous situation that, if not avoided, could result in minor or moderate injury.



The **PROHIBITION SAFETY SIGN** indicates an action **NOT** to take in order to avoid hazard.



The **MANDATORY ACTION SIGN** indicates an action that **NEEDS** to be taken to avoid a hazard.



WARNING

Failure to comply with the warnings in this manual can result in severe injury or death.



WARNING

Read this entire manual carefully before operating this vehicle. Do not attempt to operate this vehicle until you have thorough knowledge of the controls and features.



WARNING

Regular inspections and maintenance, along with good operating techniques, will help ensure your safe enjoyment of the capabilities and reliability of this vehicle.

This vehicle was designed and manufactured in the United States of America (USA). The standards and specifications in the following information originate in the USA unless otherwise indicated.

MANUFACTURER'S INTENDED USE

This vehicle is designed and manufactured for off road use only. Use on public streets, roads or highways is illegal in most areas and increases the risk of an accident involving other vehicles and people. This vehicle does not meet FMVSS (Federal Motor Vehicle Safety Standards) for public street, road or highway use.

Check all laws and regulations before choosing an area to operate your vehicle.

WARRANTY AND REGISTRATION

Use Original Equipment Manufacturer (OEM) approved parts to keep the warranty effective.

All information, including coverage, limitations, exclusions and how to obtain warranty service is included in the literature package with the purchase of the vehicle. It can also be obtained from your dealer.

A registration card is included in the literature package with the purchase of the vehicle.

BATTERY PROLONGED STORAGE

NOTICE: *Improper storage may damage, destroy or cause permanent loss of battery capacity. Do not exceed storage time or temperature limits. Batteries must be charged to the correct level before storage. Storing fully depleted batteries will make them permanently unusable.*

Storage Preparation

The optimum storage temperature range is between 65°F and 82°F (18°C and 28°C)

- Charge the battery module based on climate during storage period.
 - In cold climates, fully charge the battery module. Make sure that the charging operation is complete and there are no faults displayed on the charger. The green light on the charger should be on, indicating the charge cycle is complete.
 - In hot climates, store the vehicle with a 30% to 50% charge of battery pack capacity.
- Turn the key to the OFF position and remove it from the key switch.
- Check the run - tow switch under the seat, make sure it is set in the TOW/STORAGE position.
- Turn off all accessories.

INTRODUCTION

The storage time for properly charged Lithium-Ion batteries supplied with this vehicle varies based on the ambient temperature.

Temperature	Length of Storage Time
-22°F to -4°F (-30°C to -20°C)	One month at 100% battery charge, all accessories turned off.
-4°F to 113°F (-20°C to 45°C)	Six months at 100% battery charge, all accessories turned off.
113°F to 140°F (45°C to 60°C)	One month at 30% - 50% charge, all accessories turned off.

Setting State of Charge (SOC)

The optional SOC meter or the hand held programmer may be used to determine the state of charge of the battery module. If the SOC is below 30%, charge the battery module until the state of charge reaches 50%. The charge cycle may be interrupted by disconnecting the charger from the AC power source first, then from the charging receptacle on the vehicle. If the SOC is above 50%, operate the vehicle until the SOC is below 50%.

During Storage

Check the state of charge every 30 days. If the SOC is below 30%, charge the battery module until the state of charge reaches 50%.

Extreme Low Temperature Storage

If the ambient temperature is below -4°F (-20°C) DO NOT:

- turn the vehicle key to the ON position
- drive the vehicle
- tow the vehicle
- charge the vehicle
- operate accessories
- turn the lights on (if equipped)

Returning Vehicle to Service

At the end of the storage period, charge the battery module to 100% before operating the vehicle.

Before charging the vehicle be sure that the ambient temperature is between 14°F (-10°C) and 113°F (45°C) and the vehicle has had time to adjust to the temperature.

BATTERY DISPOSAL



Lithium-Ion batteries are recyclable:

- Contact the distributor or manufacturer for information on returning or recycling used or damaged battery packs.
- Contact local or state environmental department for disposal information.
- Refer to the Maintenance section for additional information.

VEHICLE IDENTIFICATION NUMBERS

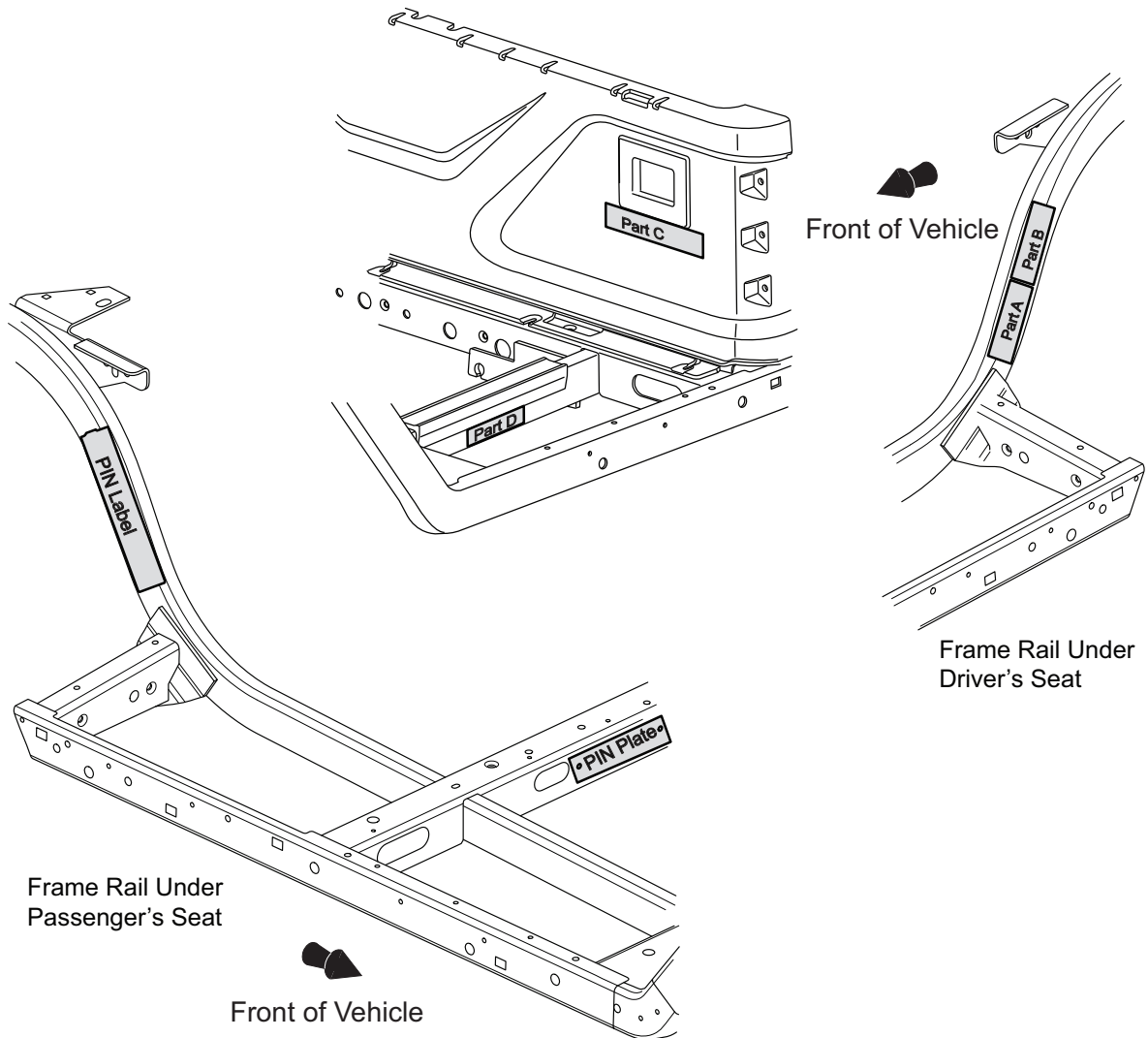

Serial number and manufacture date code/PIN plates are located on the vehicle in the following locations (shown above):

- Serial label “Part A” and “Part B” - Located on the frame rail under the driver’s seat. Lift seat to access.
- Serial label “Part C” - Located under the charger receptacle.
- Serial label “Part D” - Located on the frame tube below the driver’s side floorboard.
- PIN label - Located on the frame rail under the passenger’s seat. Lift seat to access.
- PIN plate - Located on the frame cross member below the floorboard.

Record the vehicle identification numbers in the spaces provided below. These identification numbers are required when ordering parts from TSV.

Vehicle Model Number: _____

Frame PIN: _____

REPAIR AND PARTS MANUALS

The following manuals can be purchased through a dealer:

- repair manual
- parts manual

INTRODUCTION

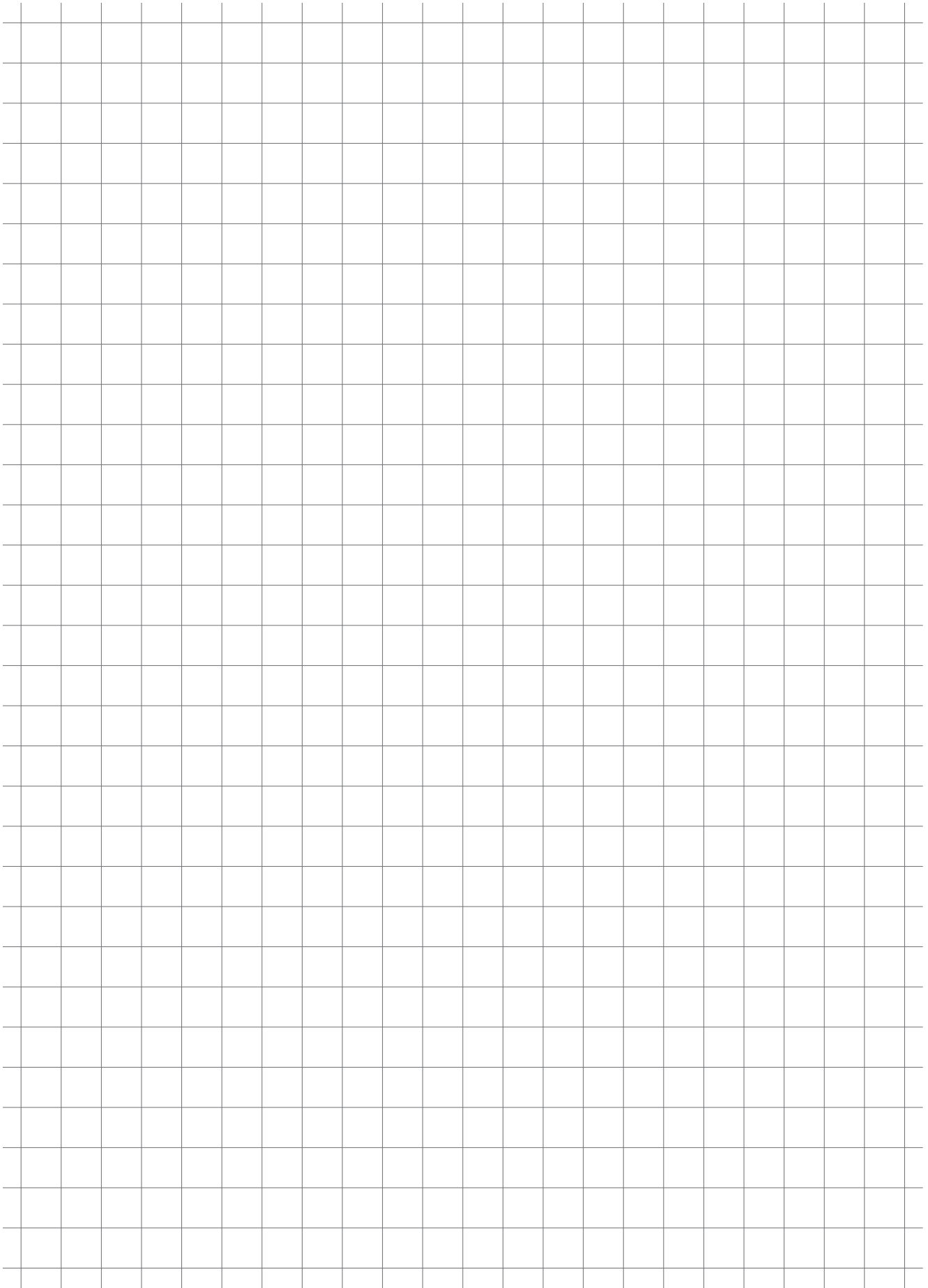

SAFETY

For questions about your vehicle or the material in this manual, see the contact information on page i or the back of this publication.

Certain replacement parts can be used independently and/or in combination with other accessories to modify a TSV (Augusta) manufactured vehicle to permit the vehicle to operate at or in excess of 20 mph. When a TSV-manufactured vehicle is modified in any way by the Distributor, Dealer or customer to operate at or in excess of 20 mph on public streets or roads, UNDER FEDERAL LAW the modified product will be a Low Speed Vehicle (LSV) subject to the strictures and requirements of Federal Motor Vehicle Safety Standard 571.500. In these instances, pursuant to Federal law the Distributor or Dealer MUST equip the product with headlights, tail lights, turn signals, seat belts, top, horn and all other modifications for LSV's mandated in FMVSS 571.500, and affix a Vehicle Identification Number to the product in accordance with the requirements of FMVSS 571.565. Pursuant to FMVSS 571.500, and in accordance with the State laws applicable in the places of sale and use of the product, the Distributor, Dealer or customer modifying the vehicle also will be the Final Vehicle Manufacturer for the LSV, and required to title or register the vehicle as mandated by State law.

Information on FMVSS 571.500 is found at Title 49 of the Code of Federal Regulations, section 571.500. For information on line, go to www.ecfr.gov.

TSV will NOT approve Distributor, Dealer or customer changes that change a TSV product into a Low Speed Vehicle (LSV).

This vehicle meets the current applicable standard for safety and performance requirements.

SAFETY LABELS

Safety and warning labels are on the vehicle for your protection. Read and comply with the instructions on the labels carefully. If any label shown in this manual is different from the label on your vehicle, always follow the instructions on the vehicle label.

If a label comes off or becomes illegible, contact your TSV dealer for a replacement. The part number is provided in this manual, printed on the label, or can be obtained from your dealer.

Operation (P/N 651654)

Located adjacent to the steering column.

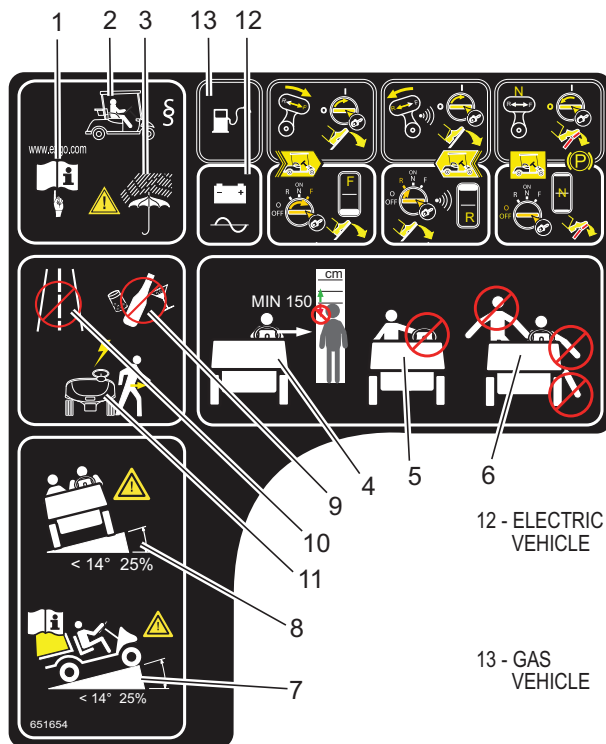

- 1 - READ THE MANUAL
- 2 - DRIVE IN ACCORDANCE WITH LOCAL LAWS AND REGULATIONS
- 3 - USE CAUTION IN BAD WEATHER
- 4 - MINIMUM HEIGHT REQUIRED TO DRIVE
- 5 - NO OPERATION FROM PASSENGER SEAT
- 6 - NO STANDING AND KEEP ENTIRE BODY INSIDE VEHICLE
- 7 - REFER TO OWNER'S MANUAL FOR CARGO INFORMATION
- 8 - MAXIMUM CROSS RAMP OR HILL
- 9 - NO OPERATION IF USING DRUGS OR ALCOHOL
- 10 - NO OPERATION ON PUBLIC ROADS
- 11 - EXIT VEHICLE WHEN LIGHTNING IS IN AREA

<p>12 - ELECTRIC VEHICLE</p> <ul style="list-style-type: none"> - KEY IN F - PRESS ACCELERATOR GRADUALLY 	<p>FORWARD OPERATION</p> <ul style="list-style-type: none"> - KEY IN R - PRESS ACCELERATOR GRADUALLY 	<p>REVERSE OPERATION</p> <ul style="list-style-type: none"> - KEY IN R - PRESS ACCELERATOR GRADUALLY 	<p>PARK VEHICLE</p> <ul style="list-style-type: none"> - STOP VEHICLE - REMOVE FOOT FROM ACCELERATOR - TURN KEY TO OFF
<p>13 - GAS VEHICLE</p> <ul style="list-style-type: none"> - TURN KEY TO ON - PUT DIRECTION SELECTOR TO F - PRESS ACCELERATOR GRADUALLY 	<p>FORWARD OPERATION</p> <ul style="list-style-type: none"> - TURN KEY TO ON - PUT DIRECTION SELECTOR IN R - PRESS ACCELERATOR GRADUALLY 	<p>REVERSE OPERATION</p> <ul style="list-style-type: none"> - TURN KEY TO ON - PUT DIRECTION SELECTOR IN R - PRESS ACCELERATOR GRADUALLY 	<p>PARK VEHICLE</p> <ul style="list-style-type: none"> - PUT DIRECTION SELECTOR IN F - TURN KEY TO OFF - ENGAGE PARKING BRAKE

SAFETY

Operation (P/N 664789) (If equipped with card holder)

Located on the steering wheel.

WARNING READ AND OBEY THE FOLLOWING WARNINGS TO DECREASE RISK OF SEVERE INJURY OR DEATH. 664789

Pressing the accelerator pedal releases the parking brake even when the key is in the OFF position; the vehicle may move when the accelerator pedal is pressed. Unintentional movement of the vehicle can cause injury or death. Do not allow anyone to stand directly in front or behind the vehicle. • Driver must have a valid driver's license. • Do not operate vehicle until all occupants are properly seated with their backs against the seat and feet flat on the floor. • Do not leave children unattended or allow them to play on a parked vehicle.

SAFETY INSTRUCTIONS

BEFORE OPERATING

- READ the owner's manual and all warning labels. Contact an authorized dealer or go to the manufacturer's website for replacement manual or labels. • This vehicle is equipped for personal use in most communities; however, state law or local rules may require additional equipment in your community.

SAFE OPERATION & PARKING

- Turn key to ON, select Forward or Reverse, release the parking brake (if required), and slowly press accelerator pedal. • Always bring vehicle to a complete stop before shifting the direction selector. • Always remain seated in a moving vehicle. • Operate from the driver's seat only. • Never drink alcohol or use drugs or medications before or during operation of the vehicle. • ALWAYS engage the parking brake and remove the key before leaving the vehicle. In an electric vehicle, put the direction selector in OFF or Neutral; in a gasoline vehicle, put the selector in Forward.

MAINTENANCE & TOWING

- This vehicle requires regularly scheduled maintenance (see the periodic service schedule in owner's manual). • ONLY qualified personnel should service this vehicle. • Vehicle is not to be towed; consult owner's manual for transport instructions.

Bed Latch Warning (P/N 74099G01)

Located on the side panel near rear fender.

KEEP HANDS AND FINGERS AWAY FROM DUMP BED.

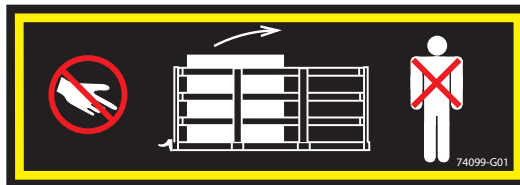

DO NOT STAND BEHIND DUMP BED.

Load Bed (P/N 74821G06)

Located on the truck bed.

Pinch Warning (P/N 651671)

Located on rear side panels.



PINCH WARNING
KEEP HANDS AND FINGERS AWAY

Run/Tow Switch Operation (P/N 679115)

Located on the run/tow switch.

⚠ WARNING

- DO NOT** alter or tamper with this unit. Unauthorized modifications can result in **SERIOUS INJURY** or damage to the vehicle and will void the warranty.
- To disable electrical system, turn key switch to 'OFF' and set the RUN-TOW switch to TOW. Disconnect the battery cables.
-  **ALWAYS** set the RUN-TOW switch to TOW/STORAGE before disconnecting or connecting battery wires. **ELECTRICAL ARC** or **BATTERY EXPLOSION** can occur if the switch is **NOT** set to TOW/STORAGE.
- WAIT 30 seconds** after reconnecting batteries **BEFORE** moving the RUN-TOW switch to the RUN position.

TOWING - Always select 'TOW' position before towing

RUN ←

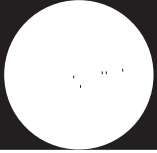

→ TOW STORAGE ○

679115

MAXIMUM CARGO LOAD / MAXIMUM WEIGHT CAPACITY

⚠ WARNING Exceeding the weight capacities can cause loss of vehicle control and possible injury or death.

Maximum Cargo Load Capacity	400 lbs. (180 kg)
Maximum Vehicle Weight Capacity	800 lbs. (360 kg)

- Do not exceed the maximum cargo load capacity.
- Do not exceed the maximum vehicle weight capacity (includes weight of operator, passenger, cargo and accessories).

TIRE PRESSURE

⚠ WARNING Improper tire pressure or uneven tire pressure can cause loss of vehicle control and possible injury or death.

Maintaining correct tire inflation pressure is essential for safe vehicle operation. You can vary the inflation pressure, within the recommended range to suit the condition of the terrain.

TIRE PRESSURE RANGE	TERRAIN CONDITIONS	RECOMMENDATION
18 - 22 psi (124 - 152 kPa)	hard surfaces or pavement	Inflate to higher pressure within the range; never exceed maximum pressure indicated.
	soft terrain or turf	Inflate to lower pressure within the range to reduce potential damage to the terrain or turf.

OPERATOR SAFETY

Safe and responsible use of this vehicle is necessary to prevent dangerous conditions for the operator, passengers and other people in the area of operation. This section of the manual provides information on the safe operation of the vehicle. Make sure you read, understand and comply with all of this information to decrease the risk of personal injury or death.

⚠ WARNING Serious injury or death can occur if you do not follow the instructions and procedures shown in this owner's manual.

- Read this entire manual and all product labels carefully. Follow the safety information and operating procedures described.
- Operate your vehicle responsibly to prevent dangerous conditions for the operator, passengers and other people in the area of operation.
- Operate your vehicle responsibly and keep the vehicle in safe operating condition.

SAFETY

- A damaged vehicle, or a vehicle that is not functioning properly is dangerous and must not be operated until repairs are made.
- Do not carry a passenger until you have a minimum of two hours driving experience on this vehicle.
- Keep feet, legs, hands and arms inside the vehicle at all times.
- The driver must keep both hands on the steering wheel and both feet on the floor or a pedal.
- Inspect the vehicle before each use to make sure it is in safe operating condition. Perform the pre-ride inspection described in this manual. See page 17.
- Always have the vehicle checked by an authorized dealer if it is involved in an accident.
- Always set the key switch to the OFF position and engage the parking brake before you exit the vehicle.
- Remove the ignition key when the vehicle is not in use to prevent accidental starting, unauthorized use by someone below the age of 16, or someone without a driver's license and proper training.
- Drive the vehicle at appropriate speeds for the terrain and conditions. Be aware of environmental conditions that change the terrain and your ability to control the vehicle.
- Do not drive on excessively steep hills. Evaluate the terrain before descending a hill. Drive slowly and deliberately. Use the brake to limit speed and maintain control. Sudden braking or turning can cause loss of vehicle control. Drive straight down the hill; do not drive across the hill.
- Operate only in approved areas. Follow all applicable safety rules for the area.
- Avoid driving on terrain that is too rough for your vehicle's capabilities and your driving skills.
- Before you drive in the reverse direction, make sure the area behind the vehicle is clear. Accelerate slowly and avoid making sharp turns.
- Make sure the direction selector is in the correct position before you press the accelerator pedal.
- Decrease speed before and during turns.
- Decrease speed when driving on wet or slippery surfaces.
- Bring the vehicle to a complete stop before you move the direction selector.
- Do not exceed the cargo or vehicle weight capacities. Do not exceed the occupant capacity. See *SPECIFICATIONS* on page 53 for the vehicle load and seat capacity.
- If there is a risk of lightning, leave the vehicle and look for a safe location to wait until the lightning has stopped.

Additional information about safety is included throughout this manual or can be obtained from your local TSV dealer.

⚠ WARNING Failure to operate this vehicle as instructed can cause collision, loss of control or roll-over resulting in severe injury or death. Follow all safety warnings in this section of the owner's manual. See the **OPERATION** section of the owner's manual for operating procedures and additional safety information.

Unauthorized Operation



This vehicle is for adult use only. Any person below the age of 16 is not permitted to operate the vehicle.

Any person who does not have a valid driver's license is not permitted to operate the vehicle.

Any person who is below the height of 59 in. (150 cm) is not permitted to operate the vehicle.

Leaving the keys in the ignition allows unauthorized operation of the vehicle by someone under 16 years of age, an unlicensed driver or someone who does not meet the height requirement. Always remove the ignition key when the vehicle is not in operation.

Operating without Instruction



Operation of this vehicle without proper instruction increases the risk of an accident. The operator must understand how to operate the vehicle correctly in different situations and on different types of terrain.

All operators must read, understand and comply with the owner's manual and all warning and instruction labels before operating the vehicle.

Alcohol or Drugs



Operation of the vehicle during or after consuming alcohol or drugs can adversely affect operator judgment, reaction time, balance and perception.

Never drink alcohol or use drugs or medications before or during operation of the vehicle.

Passenger

All passengers must be at least 59 in. (150 cm) tall. Passengers must be able to sit with their back against the seat, and both feet on the floor.

For additional safety and operational information, see *Driving with a Passenger* on page 21.

Before Operating

Perform the *PRE-RIDE INSPECTION* on page 17 before each use to make sure the vehicle is in safe operating condition. Failure to inspect and confirm that the vehicle is safe to operate increases the risk of an accident.

Follow all inspection and maintenance procedures and schedules described in this owner's manual. See *SCHEDULED MAINTENANCE CHART* on page 28.

Load Operation

The weight of cargo and occupants affects vehicle operation. Carefully calculate how the vehicle is loaded and how to safely operate it. Follow the instructions in this manual for loading guidelines and tire pressure.

Do not exceed weight capacities specified for your vehicle. Capacities are listed in *Maximum Cargo Load / Maximum Weight Capacity* on page 7 of this manual, and also on the label affixed to the truck bed. As passenger weight increases, cargo weight needs to be adjusted to ensure the maximum vehicle weight capacity is not exceeded.

Tire pressure must be adjusted to accommodate the load being carried. See *Tire Pressure* on page 7 for pressure specifications.

Verify tire pressure, and drive slowly and carefully to maintain control of the vehicle if driving under any of the following conditions:

- passenger and/or cargo exceeds half the maximum weight capacity
- driving over obstacles
- towing
- climbing a hill

Driving in Reverse

Make sure the area behind the vehicle is clear before operating in reverse. After making sure it is clear and safe to operate in reverse, accelerate slowly. Avoid making sharp turns in reverse. Refer to *Driving in Reverse* on page 22 for operational information.

Driving a Damaged Vehicle

Driving a damaged vehicle is not safe.

If your vehicle has been involved in any type of accident, have it inspected by a qualified service dealer to verify that it is safe for operation.

Driving at Maximum Speeds

Maximum speed operation increases risk of loss of control. Always drive at a speed that is appropriate for the terrain, visibility, operating conditions and your skill and experience level. Use the brake to control speed and maintain control of the vehicle.

Driving on Pavement

Driving the vehicle on paved surfaces can affect handling characteristics and increase tire wear.

If possible, avoid driving on paved surfaces. If unavoidable, drive slowly, travel short distances and avoid sudden turns or stops.

Driving on Public Roads

Driving this vehicle on public streets, roads or highways could result in a collision with another vehicle. Never drive this vehicle on any public street, road or highway, including dirt and gravel roads, unless they are designated for off road use. Most areas prohibit the operation of this vehicle on public streets, roads or highways, and can result in traffic violations and fines.

Turning

Improper or careless turning can cause loss of traction, loss of control, accident or rollover. Do not turn quickly or at sharp angles. Do not turn at high speeds. Practice turning at slow speeds before attempting to turn at faster speeds.

Driving Uphill

Do not climb hills that are too steep for the vehicle or your driving abilities. Loss of vehicle control or rollover can result from climbing hills incorrectly. Refer to *Driving Uphill* on page 21 for operational information.

SAFETY

Driving Downhill

Inspect the terrain before descending a hill. Avoid driving across hills. Use the brake to limit speed and maintain control. Loss of vehicle control or rollover can result from driving downhill incorrectly. Refer to *Driving Downhill* on page 22 for operational information.

Stalling on a Hill

A rollover can result from stalling or rolling backward while climbing a hill. Drive uphill at a constant speed. See procedure on page 22 for maintaining control of your vehicle if it stalls on a hill.

Tires

Operating the vehicle with incorrect tires or with incorrect or uneven tire pressure can cause loss of control or an accident. Always use the size and type tires specified for the vehicle. See *VEHICLE SPECIFICATIONS* on page 53. Always maintain correct tire pressures as specified in *Tire Pressure* on page 7.

Slippery Terrain

Driving on rough, wet or loose terrain increases the risk of loss of traction or control, accident or rollover. Drive slowly and use correct turning procedures when operating on slippery surfaces.

Tires that have lost traction, and then regain traction suddenly, can cause loss of vehicle control or rollover.

Refer to *Slippery Surfaces* on page 21 for operational information.

BATTERY CHARGING

Charging should be performed when ambient temperatures are between 40°F and 110°F (4°C and 42°C). The battery pack may be charged or topped off after every use.

The battery management system (BMS) and charger cooperate to make sure that charging occurs at the proper rate for the battery temperature. When the battery charger is connected to the vehicle, it will determine the charge rate based on the battery temperature. The charger will operate at the rates shown in the table below.

Charge Rate	Temperature
NO charging	below 14° F (-10°C) or above 140°F (60°C)
Pre-charge (charge at reduced rate, 6 amps)	between 14°F (-10°C) and 41°F (5°C) between 104°F (40°C) and 140°F (60°C)
Full charging	between 37.4°F (3°C) and 107.6°F (42° C)

The BMS will adjust the charge rate based on the temperature of the batteries.

Use only the OEM approved Lithium-Ion battery charger for your vehicle. See charger operating instructions in Appendix A.

- Turn the key to the OFF position and remove it.
- Inspect the charger cord for cracks, frayed wires or loose connections, if damaged, replace it.
- Inspect the vehicle charger receptacle and charger plug for dirt, debris or damage. Clean if necessary and replace immediately if damage is found.
- Connect the charger to a wall receptacle. Do not use a multi-plug adapter or power strip. Do not connect anything else to the same receptacle.
- Connect the charger to the vehicle receptacle.
- When the battery pack is finished charging, disconnect the charger cord from the vehicle. If disconnecting before the charge cycle is complete, it is recommended that the charger be disconnected from the wall receptacle first, then unplug the charger from the vehicle receptacle.

VEHICLE LIFTING

The vehicle must be on a firm and level surface for lifting. Remain constantly aware that the vehicle is not stable during the lifting process. Do not get under a vehicle until you verify that it is stable on the jack stands. Never get under a vehicle while it is on a jack only. Put wheel chocks in front and behind the wheels that are not being lifted. Do not allow anyone to remain or get on the vehicle at any time during the lifting process.

Read and comply with all warnings and follow the lifting procedures described on page 30.

VEHICLE MODIFICATION

Do not install any accessory not approved by TSV. Do not modify the vehicle to increase speed or power. Any modifications or installation of accessories not approved by TSV can create a safety hazard and increase the risk of injury. The warranty will be terminated if the vehicle is modified to increase vehicle speed or power.

The warranty may be terminated if original (or equivalent) replacement parts are not installed on the vehicle.

The addition of some accessories can change the handling characteristics of the vehicle. Use only TSV approved accessories, and familiarize yourself with their function and effect on the vehicle.

MAINTENANCE SAFETY

Routine and scheduled maintenance of this vehicle is necessary to keep your vehicle in safe and reliable condition. This section of the manual provides safety information for performing maintenance on your vehicle. Make sure you read, understand and comply with all of this information to decrease the risk of personal injury or death.



WARNING Serious injury or death can occur if you do not follow the instructions and procedures shown in this owner's manual.

- Read this entire manual and all product labels carefully. Follow the procedures and comply with the safety information in this manual while performing vehicle service or maintenance.
- Use the tools shown in the tool list and wear the specified safety equipment when performing vehicle service or maintenance.
- Remove all jewelry before you service the vehicle.
- Do not allow loose clothing or hair to contact the moving parts.
- Do not touch hot objects.
- The drive wheels must be lifted and supported on jack stands before you perform any service to the powertrain while the motor is in operation.
- Use wheel chocks and support the vehicle on jack stands. NEVER get under a vehicle that is supported by a jack. Lift the vehicle following instructions. See *LIFTING THE VEHICLE* on page 30.



- When you service the vehicle, always wear eye protection. Be careful when working around batteries, using solvents or compressed air.
- Use insulated tools within the battery area to prevent sparks or battery explosion.
- To prevent the risk of battery explosion, keep all flammable materials, open flames or sparks away from the battery.
- Maintain constant awareness that some components are heavy, spring loaded, corrosive, explosive, can cause high amperage or get extremely hot.
- After you make repairs or do maintenance, test the vehicle in a safe area that is free from vehicle and person traffic.

SAFETY

FEATURES AND CONTROLS

NOTICE: Some accessories continue to operate with the key in the OFF position. Leaving these accessories activated after the vehicle is shut down can cause the battery to discharge.

12V accessories must be connected to the DC to DC converter. Converter is rated for 300 Watt output. Exceeding this power rating may result in unintended accessory operation or failure.

KEY SWITCH

The key switch is a four-position switch.

- OFF; vehicle is disabled.
- REVERSE; activates vehicle electronics and accessory power, and allows driving in reverse direction.
- NEUTRAL; activates vehicle electronics and accessory power.
- FORWARD; activates vehicle electronics and accessory power, and allows driving in forward direction.

HEADLIGHT SWITCH

Halogen

The Halogen headlight switch is a two-position switch.

Two-position:

- upper – on
- lower – off

LED (If Equipped)

The LED headlight switch is a three-position switch.

Three-position:

- upper – high beam
- middle - low beam
- lower – off

ELECTRIC BED LIFT SWITCH (If Equipped)

If the vehicle is equipped with an electric bed lift, the switch is the last toggle switch on the right on the console. Press and hold the top of the switch to raise the bed. Press and hold the lower part of the switch to lower the bed.

STATE OF CHARGE METER

The state of charge meter is located on the dash panel beside the key switch. It indicates the percentage of usable battery power. The yellow light indicates the battery must be charged immediately.

HORN

The horn switch is the red switch on the dash panel, press the top of the switch to activate the horn.

CUP HOLDER

The vehicle has a center cup holder that will accommodate two beverage containers. Another cup holder is located to the left of the steering column and will accommodate a larger beverage container.

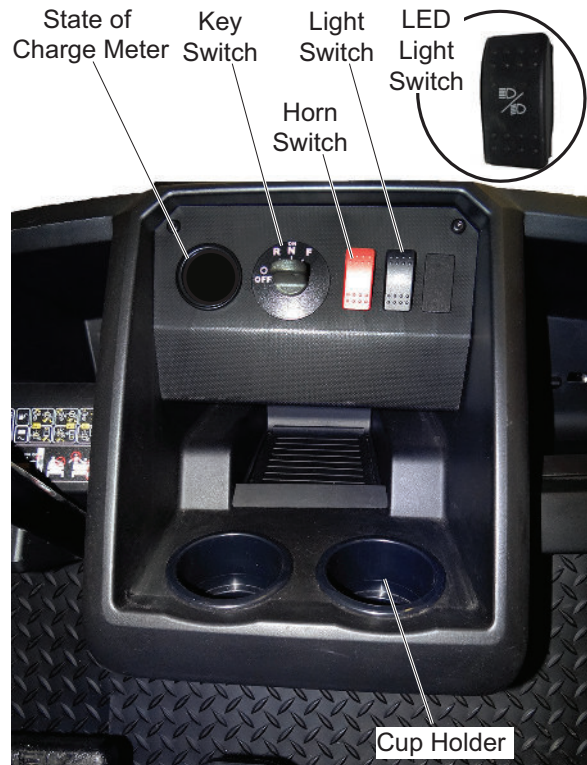

FEATURES AND CONTROLS

12V OUTLET (If Equipped)

CAUTION Excessive use of accessories that are connected to the outlet can drain the battery.

A 12V auxiliary outlet is located on the center console.

With the key switch in the ON position, the auxiliary outlet supplies power for any lights and accessories that have a 12V plug.

USB PORT (If Equipped)

A USB port is located on the center console.

With the key switch in the ON position, the USB port supplies power to electronic devices via a USB cable.

HOUR METER (If Equipped)

The hour meter is located under the driver's seat and indicates the vehicle's total hours of operation.

STEERING WHEEL

The steering wheel allows the driver to control the direction of travel.

TURN SIGNAL/HORN (If Equipped)

The turn signal switch also controls the hazard lights and horn. The switch is located on the steering column.

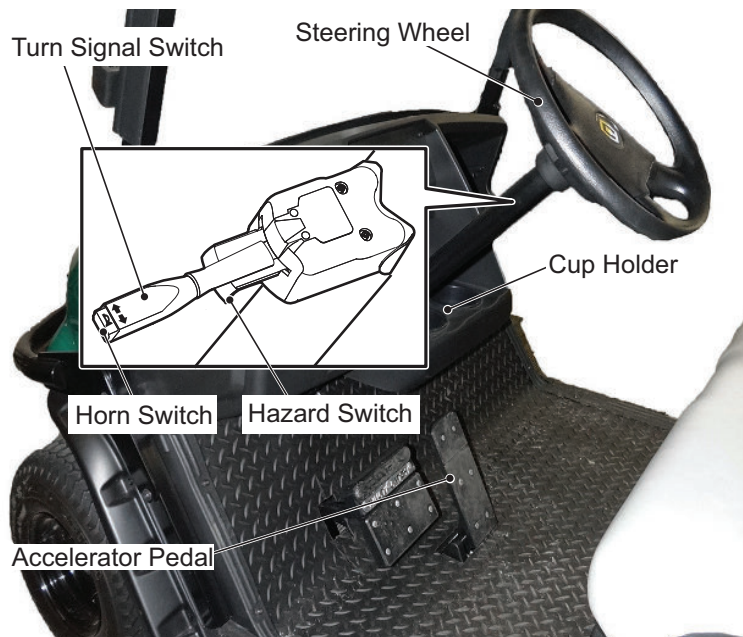

Run/Tow Switch

CAUTION Before you attempt to tow the vehicle, turn the key switch to N and move the Run/Tow switch to the TOW position. Failure to do so will damage the controller or the motor.

The Run/Tow switch is located under the seat on the passenger side of the vehicle.

BRAKE PEDALS

The brake pedal is a combination brake and parking brake pedal.

FEATURES AND CONTROLS

Brake Pedal

The brake pedal is the bottom left pedal on the floorboard.

Press the brake pedal to slow the speed or bring the vehicle to a complete stop.

Parking Brake Pedal

The parking brake is the upper pedal. It allows the operator to lock the brake when the vehicle is parked to prevent accidental movement.

To engage the parking brake, press the upper pedal until it locks into place.

NOTICE: *Vehicles equipped with the 4-wheel mechanical brake option have a parking brake with multiple engagement levels. Each additional level that the latch is engaged increases the amount of braking applied.*

Quickly press and release the lower pedal to disengage the parking brake.

NOTICE: *If the key switch is in the ON position and the parking brake is engaged, the brake will release when you press the accelerator pedal and can cause the vehicle to move suddenly. This is a feature to make sure the vehicle is not driven with the parking brake engaged. Pressing the accelerator pedal is not the recommended method to release the parking brake.*

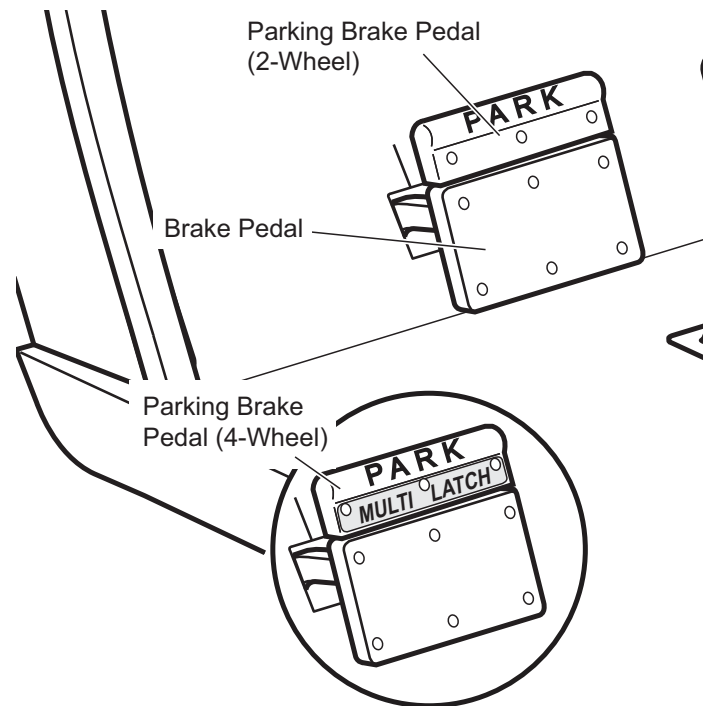

ACCELERATOR PEDAL

The accelerator pedal is the right pedal on the floorboard. It activates the motor and controls the acceleration of the vehicle.

Apply slow and steady pressure to the accelerator pedal to increase vehicle speed.

DIRECTION SELECTOR

The direction selector is the key switch. The switch allows the operator to select F (forward), N (neutral), or R (reverse).

When you leave the vehicle turn the key switch to OFF, set the parking brake and remove the key.

SEAT BOTTOM

The bench seat is designed for two occupants.

Lift up on either hip restraint to pivot the seat bottom forward to access the components underneath. Pivot and lift up on the seat to completely remove it from the vehicle.

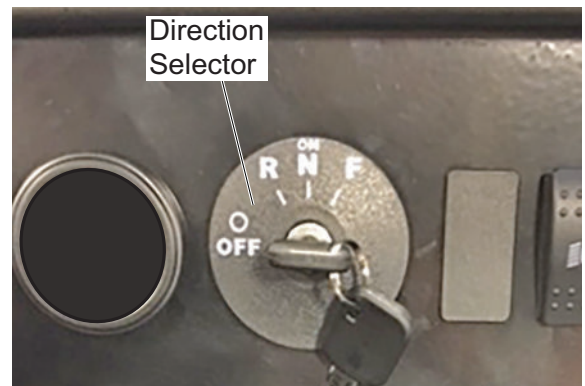

GLOVE BOX / STORAGE COMPARTMENTS

The glove box provides storage space for small items. Glove boxes may be equipped with optional shelf and/or glove box door.

FEATURES AND CONTROLS

TRUCK BED

To prevent injury and property damage, follow all warnings, procedures, and weight capacities described on the label in the truck bed as well as the ones in this owner's manual. See *HAULING CARGO* on page 23 and *DUMPING THE TRUCK BED* on page 24.

The tailgate can be opened for loading and unloading cargo.

Open the tailgate latches and lower the tailgate.

Lift the tailgate and secure the latches to close the tailgate.

Max weight on tailgate is 100 lbs. (45 kg).



Canopy Top and Windshield

WARNING

The canopy top does not provide protection from rollover or falling objects.

The windshield does not provide protection from tree branches or moving objects.

CAUTION

To prevent damage to the vehicle, do not hold on to the canopy top struts.

The canopy top and windshield provide some protection from the elements, but do not keep the operator and passenger dry in heavy rain.

This vehicle is not equipped with seat belts, and the canopy top is not designed to provide rollover protection. In addition, the canopy top does not protect against falling objects, nor does the windshield protect against flying objects and tree limbs.

OPERATION

SAFETY

WARNING

Failure to operate the vehicle correctly can result in a collision, loss of control, accident or rollover, and cause serious injury or death. Follow all operation procedures in this section of the manual. Read and comply with all safety warnings in the safety section of this owner's manual.

BEFORE INITIAL USE

To prepare your new vehicle for operation, complete the following:

- Remove the protective plastic from the seats.
- Check for possible leaks that may have developed during shipment of the vehicle.

WARNING

Never charge a vehicle near flammable materials, open flame or sparks. Never charge a vehicle near gas water heaters and furnaces.

- Charge the batteries.
- Perform the following pre-ride inspection.

PRE-RIDE INSPECTION

Inspect and verify that the vehicle is in safe operating condition before each use to decrease the risk of an accident. Check the items in the table to help ensure safe and reliable operation.

Item	Check	Page
Batteries	Check charge level.	
Brake system / pedal travel	Check for proper operation.	35
Parking brake	Make sure vehicle does not roll when the parking brake is engaged.	
Front suspension	Inspect. Lubricate if necessary. Check for loose or missing hardware.	
Rear suspension	Inspect. Lubricate if necessary. Check for loose or missing hardware.	
Steering	Check for smooth and free operation.	
Tires	Check condition and pressure.	31
Wheel hardware	Check for loose or missing hardware.	
Frame hardware	Check for loose or missing hardware.	
Fluid leakage	Inspect shocks, differential, and vehicle for leaks.	
Switches	Check operation.	
Reverse warning alarm	Check operation.	
Headlights	Check operation.	33
Brake light / taillights	Check operation.	33

ENVIRONMENTAL AWARENESS

WARNING

When driving the vehicle, be careful of potential environmental hazards like steep slopes, rocks, tree branches, etc. that could cause an incident that could result in vehicle damage, personal injury or death.

CAUTION

There is a risk of fire when the vehicle is operated near combustible material.

Always be respectful of the environment.

Respect all wildlife and their habitat.

Respect private property and comply with all local laws and regulations governing the use of light duty utility vehicles.

Make sure you are permitted by property owners to operate the vehicle on their property.

If operating your vehicle on private property, obtain permission from the owner prior to entering their property.

OPERATION

BATTERY CHARGER

The charger should be operated in accordance with the charger manufacturer's instructions. Always place the charger outside the vehicle before and during the charging cycle. Never charge batteries in a hazardous environment.

⚠ DANGER Risk of electric shock. Connect the charger power cord to an outlet that is correctly installed and connected to an electrical ground according to all codes and regulations. A grounded outlet is necessary to decrease the risk of electric shock – do not use ground adapters or replace the plug. Do not touch parts of output connector or battery terminals that do not have insulation.

Disconnect the AC plug before you make or break the connections to a battery that is charging. Do not open or disassemble the charger. Do not operate the charger if the AC cord is damaged. Make sure qualified personnel does all repair work to the charger.

Refer to APPENDIX A for the charger manufacturer User's Guide for operating instructions, maintenance instructions and troubleshooting instructions.

The battery charger will test the temperature of the battery pack, if the temperature is too hot or too cold the charger will shutdown. If the battery pack temperature is within the safe to charge range the charger will operate.

PERFORMANCE FEATURES

NOTICE: *The vehicle operates when the Run/Tow switch is in the RUN position.*

The speed of the motor is sensed and controlled by the controller.

Speed Control

⚠ WARNING The speed control system is not an alternative for the brake. Use the brake to control speed and decrease the risk of injury.

Speed control system vehicles are equipped with a regenerative motor control system.

Example: If all of the following events occur:

- the vehicle is being driven down a slope
- the vehicle attempts to exceed the specified top speed with the accelerator pedal pressed **or** released

the regenerative brake will limit the speed of the vehicle to the specified top speed but the warning beeper will **not** activate. When the regenerative braking system is activated by this sequence of occurrences, the motor generates power which is returned to the batteries.

If the operator tries to override the electronic brake feature by moving the direction selector or key switch to another position the vehicle will brake **quickly** until it reaches approximately 2 mph (3 kph).

Pedal-Up Braking

Pedal-up braking is regenerative braking that occurs when the accelerator pedal is released while the vehicle is moving.

Example: If all of the following events occur:

- the vehicle is being driven down a slope
- the accelerator pedal is released

the pedal-up braking decreases speed until the vehicle stops or the accelerator pedal is applied. The warning beeper will **not** activate. When pedal-up braking is activated by this sequence of occurrences, the motor generates power which is returned to the batteries.

Walk-Away Feature

Walk-Away limits vehicle movement without driver input, decreases vehicle speed to 2 mph (3 kph) and activates an alarm.

Example: If all of the following events occur:

- the vehicle is stopped for more than 2 seconds
- the accelerator pedal is released for more than one second
- the vehicle starts to move at more than 2 mph (3 kph)

the Walk-Away feature limits speed to approximately 2 mph (3 kph) and the warning beeper activates. When the accelerator pedal is pressed, the Walk-Away feature and warning beeper stops and normal vehicle operation continues.

Anti-Roll Back Feature

Anti-Roll Back, like Walk-Away, limits reverse motion of the vehicle down a slope to less than 2 mph (3 kph). See Walk-Away Feature for more information. An alarm will not be activated should the anti-roll back feature engage.

Anti-Stall Feature

Anti-Stall protection prevents motor damage if the vehicle is stalled against an object or on a hill.

Example: If all of the following events occur:

- the system senses that the accelerator pedal is pressed (power applied to motor)
- the motor is stopped long enough that additional time can cause damage to the motor

the Anti-Stall feature will interrupt power to the motor. To restore power to the motor, flip the RUN/TOW switch to "TOW" position and then return the switch to "RUN" position.

High Pedal Disable Feature

High Pedal Disable prevents acceleration of the vehicle if the direction selector is changed or the key is turned on while the accelerator is pressed.

Diagnostic Mode Feature

Diagnostic mode helps with troubleshooting.

With some electrical system failures, the Diagnostic Mode feature defaults to a mode that allows the vehicle to operate at a decreased speed.

This feature allows you to return the vehicle to the storage facility and identify the problem.

STARTING AND STOPPING THE VEHICLE

WARNING

Unintentional roll-back of the vehicle could cause severe personal injury or vehicle damage. To reduce the possibility of vehicle roll-back, keep the brake fully pressed until the motor has started.

All vehicles have an *interlock system* that disables the controller and prevents operation of the vehicle while the charger is connected. Remove the charger plug from the receptacle and correctly store the cord before you move the vehicle.

1. Sit in the driver's seat.
2. Press and hold the brake pedal.
3. Insert the key and turn to the desired direction.

NOTICE: When the direction selector is moved to the reverse position, a warning alarm will activate to indicate that the vehicle is ready to run in reverse.

4. Slowly press the accelerator pedal to start the motor.
5. When the accelerator pedal is released, the motor decreases the speed of the vehicle. To stop the vehicle more quickly, press the brake pedal.
6. Engage the parking brake, turn the key to OFF and remove the key from the switch before exiting the vehicle.

Starting on a Hill

WARNING

Unintentional roll-back of the vehicle could cause severe personal injury or vehicle damage. To reduce the possibility of vehicle roll-back, keep the brake fully pressed until the motor has started.

CAUTION

Do not use the accelerator and motor to hold the vehicle on a hill. Doing so for more than 3 - 4 seconds will cause permanent damage to motor.

To decrease the risk of permanent damage to the drive system, do not allow roll-back when you start the vehicle on a hill.

1. Press the brake pedal with your left foot when releasing the parking brake. Keep pressure on the pedal to prevent the vehicle from rolling back.
2. Press the accelerator pedal with your right foot as you release the brake pedal.
3. Press the accelerator pedal with gradual and steady pressure until the vehicle reaches the desired speed.

OPERATION

ACCELERATING

WARNING Accidental movement of the accelerator pedal can cause the vehicle to suddenly move and cause severe injury or death.

Make sure the key is in the OFF position and the parking brake is engaged any time the vehicle is parked.

1. Release the parking brake.
2. Move the key switch to the desired direction.
3. Apply slow, steady pressure to the accelerator pedal to increase vehicle speed. When you release the accelerator pedal, the motor decreases the speed of the vehicle.

NOTICE: *If the key switch is in the F, N, or R position and the parking brake is engaged, the brake releases when you press the accelerator pedal and can cause the vehicle to move suddenly. This is a feature to make sure the vehicle is not driven with the parking brake engaged. Pressing the accelerator pedal is not the recommended method to release the parking brake.*

BRAKING

WARNING When carrying cargo or towing a trailer, the weight of the load will increase the braking distance required to slow or stop the vehicle. Not allowing for increased braking distance under load can cause an accident or injury.

1. Release the accelerator pedal completely.

NOTICE: *Pressing the top section of the brake pedal engages the parking brake.*

2. Press the brake pedal to slow vehicle speed or stop the vehicle completely.
3. Practice slowing and stopping using the brake to become familiar with the controls.

Coasting

WARNING Do not allow the vehicle to coast at above recommended speeds. Control vehicle speed with the brake.

The vehicle has a braking feature (pedal-up) that decreases the speed when the accelerator pedal is released. The feature continues to decrease the speed until the vehicle stops. Press the brake if you need to decrease speed or stop the vehicle quickly.

DRIVING PROCEDURE

1. Perform the pre-ride inspection. See page 17.
2. Sit in the driver's seat.
3. Check surroundings and determine the path of travel.
4. Press the brake pedal and release the parking brake.
5. Insert the key and turn to the desired direction.
6. With both hands on the steering wheel, release the brake and immediately start to apply gradual and steady pressure to the accelerator pedal.
7. Practice maneuvering the vehicle using the accelerator and brake pedals. Drive slowly and cautiously until you are comfortable with the controls.
8. Do not drive with a passenger until you have at least two hours of experience driving this vehicle.

Coasting

WARNING Vehicle speed can increase quickly when driving downhill. Allowing the vehicle to coast downhill at high speeds can cause loss of control and result in severe injury or death. Limit your vehicle speed by pressing the brake.

Do not allow the vehicle to coast at speeds that are above the maximum recommended speed. Apply constant brake pressure when descending a hill to control the speed of the vehicle.

DRIVING WITH A PASSENGER

- All passengers must be at least 59 in. (150 cm) tall. Passengers must be able to sit with their back against the seat, both feet on the floor.
- Do not allow more than one passenger in the vehicle.
- Do not allow a passenger to ride anywhere on the vehicle except the passenger seat.
- Travel at speeds appropriate for your skills, your passenger's skills and the operating conditions. Avoid unexpected or aggressive maneuvers that could cause discomfort or injury to the passenger.
- Handling characteristics can change with the added weight of a passenger. Allow more time and distance for braking.

SLIPPERY SURFACES



WARNING

Skidding or sliding can cause loss of control. Skidding or sliding can cause rollover if tires have lost traction, then regain traction suddenly. When operating on slippery surfaces, travel at reduced speed to help maintain control of the vehicle.

When operating in conditions such as ice, water, muddy trails, loose gravel or freezing temperatures, follow these guidelines:

- Do not operate on excessively rough, slippery or loose terrain.
- Slow down before entering potentially slippery areas.
- Maintain a high level of alertness, carefully evaluate the path of travel and avoid quick, sharp turns.
- Correct a skid by turning the steering wheel in the direction of the skid. *Never apply the brakes during a skid.*

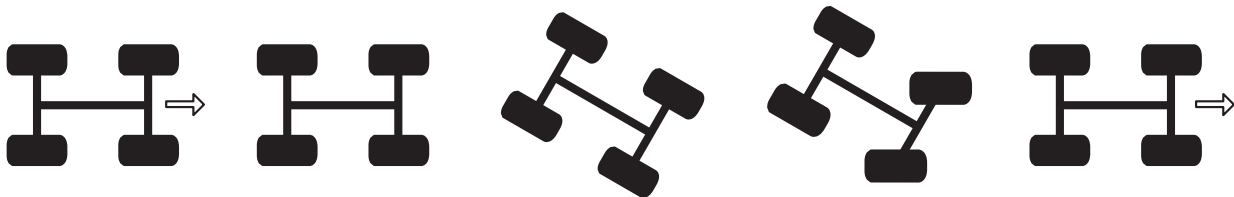

DRIVING UPHILL

When driving up a hill, follow these guidelines:

- Drive straight up the hill.
- Avoid excessively steep hills.
- Keep both feet on the floor or pedals.
- Check the terrain before driving up a hill. Do not try to climb hills that have excessively slippery or loose surfaces.
- Drive at a steady rate of acceleration and speed.
- Do not drive over the crest of a hill at high speed. An obstacle, sharp drop, or another person or vehicle could be on the other side of the hill.
- Do not attempt to drive up a hill that is beyond your skill level.

TRAVERSING HILLSIDES

Traversing a hillside is not recommended. Improper procedure can cause loss of control or a rollover. Avoid crossing the side of a hill unless absolutely necessary. If traversing a hillside is unavoidable, check the terrain and determine if it can be accomplished safely. Do not proceed if the terrain is beyond the vehicle or driver's ability.

If traversing a hillside is unavoidable, follow these guidelines:

- Drive slowly.
- Use extreme caution.
- Avoid crossing the side of a hill that has a slippery surface.
- Avoid crossing the side of a steep hill.
- When traversing a hillside that has soft terrain, it may be necessary to steer slightly uphill to keep the vehicle traveling in a straight line.
- If you feel that you are losing control of the vehicle, steer downhill if possible to regain control.

OPERATION

DRIVING DOWNHILL

⚠ WARNING When carrying cargo or towing a trailer, the weight of the load will increase the braking distance required to slow or stop the vehicle. Not allowing for increased braking distance under load can cause an accident or injury.

When driving down a hill, follow these guidelines:

- Avoid excessively steep hills.
- Check the terrain carefully before descending any hill.
- Never drive down hills with excessively slippery or loose surfaces.
- Drive slowly.
- Drive straight down the hill. Avoid descending the hill at an angle that could cause the vehicle to lean sharply to one side.
- Apply light and constant pressure to the brakes to maintain slow speed and control of the vehicle.

STALLING ON A HILL

A rollover can result from stalling or rolling backward while climbing a hill. Drive uphill at a constant speed.

If your vehicle completely stalls while climbing a hill:

1. Apply the brakes.
2. Verify that the area behind you is clear.
3. Put the direction selector in R (reverse).
4. Use steady brake pressure to control speed, and allow the vehicle to slowly roll straight downhill.

If your vehicle begins to roll downhill:

1. Do not press the accelerator.
2. Apply the brakes gradually until the vehicle fully stops.
3. Verify that the area behind you is clear.
4. Put the direction selector in R (reverse).
5. Use steady brake pressure to control speed, and allow the vehicle to slowly roll straight downhill.

DRIVING IN REVERSE

When driving in reverse, follow these guidelines:

- Check that the area behind the vehicle is clear of obstacles and people.
- Check left and right fields of vision before driving in reverse.
- Do not back down a steep hill.
- Drive in reverse slowly.
- Press the brakes lightly for stopping.
- Accelerate slow and steady.
- Avoid turning at sharp angles.

PARKING THE VEHICLE

NOTICE: When parking the vehicle in cold climates (0°C, 32°F), the car should be stored in an enclosed garage.

Park the vehicle away from any source of flame or sparks, including any appliance with a pilot light.

Park the vehicle on a flat surface if possible. If parking on an incline is unavoidable, be sure to chock the wheels as shown in the following illustration to keep the vehicle from rolling.

1. Press the brake to stop the vehicle.
2. Engage the parking brake.
3. Turn the key switch to OFF.
4. Remove the key from the ignition to prevent unauthorized use.
5. If parking on an incline, chock the wheels on the downhill end as shown in the following illustration.

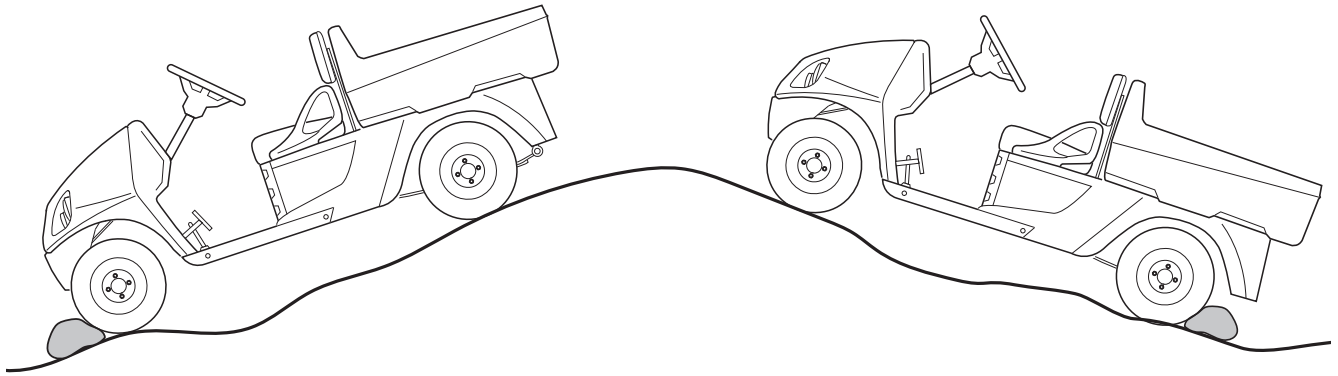

HAULING CARGO

WARNING

Hauling cargo incorrectly can alter vehicle handling characteristics and cause loss of control, brake instability, and possibly lead to serious injury or death.

Never exceed the maximum weight capacity of the vehicle. The total load (operator, passenger, accessories, cargo and load on hitch) must never exceed the maximum weight capacity of the vehicle. See the chart in *Maximum Cargo Load / Maximum Weight Capacity* on page 23.

Position the load as far forward, and as low as possible in the truck bed.

Secure all loads before operating. Unsecured loads can shift and create unstable operating conditions.



Operating the vehicle with passengers in the truck bed can result in severe injury or death. Never allow a passenger to ride in the truck bed. Passengers must always ride seated in the passenger seat.

Drive slowly and carefully.

Operate only with stable and safely arranged loads. When handling loads that are impossible to center in the truck bed, make sure the load is secured as tightly as possible and operate the vehicle with extra caution.

Reduce speed and allow greater distances for braking when hauling cargo.

Heavy loads affect braking and handling characteristics. Use extra caution when applying brakes with a heavily loaded vehicle. Avoid terrain or situations that may require reverse downhill travel.

Use extra caution when operating with loads that extend over the truck bed sides. Stability and maneuverability can be affected and increase risk of rollover.

This vehicle is designed to carry or tow specific capacities. Read and comply with the load distribution warnings on the warning label affixed to the bed. The total load (operator, passenger, accessories, cargo and load on hitch) must never exceed the maximum weight capacity of the vehicle.

Maximum Cargo Load / Maximum Weight Capacity

Maximum Cargo Load Capacity	400 lbs. (180 kg)
Maximum Vehicle Weight Capacity	800 lbs. (360 kg)

- Do not exceed the maximum cargo load capacity.
- Do not exceed the maximum vehicle weight capacity (includes weight of operator, passenger, cargo and accessories).

OPERATION

TRUCK BED OPERATION

WARNING Failure to follow these instructions can cause personal injury, damage the vehicle or cause the vehicle to tip over. Be aware of the load when you operate the vehicle. Read, understand and follow the warning label attached to the front of the truck bed.

Do not allow passengers to ride in the truck bed. A sudden move or stop can cause severe injury or death to passengers in the truck bed.

Before operating, make sure the area behind the vehicle is clear.

Load Bed (P/N 74821G06)

Located on the truck bed.

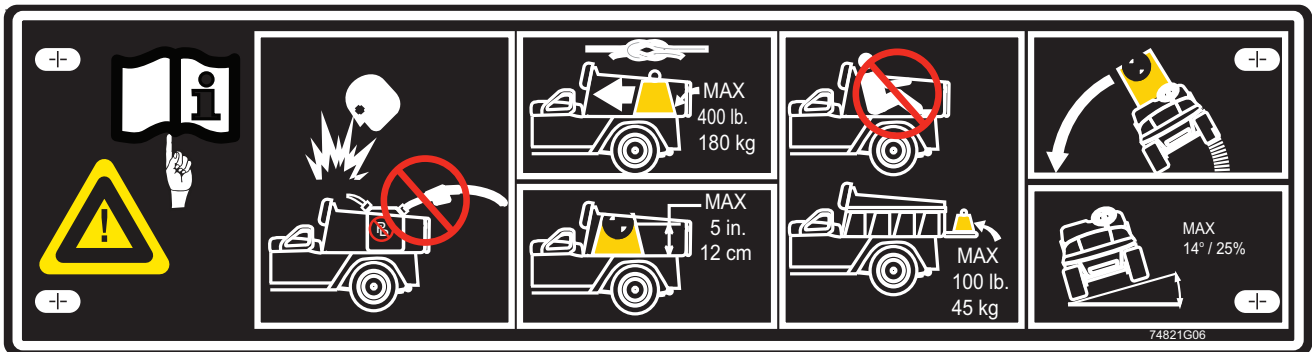

A truck bed warning label is attached to the inside front of the truck bed. Understand and comply with the warnings on this label for safe operation of the vehicle.

- See the truck bed warning label for maximum load.
- Position the load in the truck bed as far forward as possible.
- Make sure the center of gravity of the load is within the height limit shown on label.
- Secure the load to the truck bed.
- Be aware of the load when you operate the vehicle.
- Do not let passengers ride in the truck bed. Do not drive the vehicle with the truck bed lifted or with the tailgate unsupported.

DUMPING THE TRUCK BED

Manual Bed Release Lever

The truck bed can be tilted by lifting up the release lever on either side of the vehicle.

Electric Lift (If Equipped)

NOTICE: If the key switch is in the ON position and the electric lift does not function, the Battery Management System (BMS) may have entered sleep mode. Cycle the RUN/TOW switch and return it to the RUN position to wake the system.

If the vehicle has an electric lift, the switch is located on the center dash console. Press and hold the top part of the switch to raise the truck bed. Press the bottom part of the switch to lower the truck bed.

WARNING If the bulk of the cargo weight is at the rear of the bed, the bed may unexpectedly dump when the release lever is pulled and cause serious injury to anyone close by. Never pull the release lever unless the load is positioned evenly or located at the front of the truck bed.

Never leave the truck bed in the upright position after emptying the cargo. The bed can unexpectedly close and cause serious injury. Never drive the vehicle with the truck bed in the raised position.

1. Select a level location to dump the truck bed load. Do not attempt to dump or unload the vehicle if it is on an incline.
2. Apply the brakes and engage the parking brake.
3. Exit the vehicle.
4. Make sure the cargo is positioned evenly or located at the front of the truck bed.
5. Release the tailgate latches.
6. Manual bed lift vehicles:
 - a. Stand clear and pull the release handle. Lift up on the truck bed to dump the cargo.
 - b. When the truck bed is empty, lower the bed back into place.
 - c. Push down to latch the bed.

Electric lift vehicles:

 - a. Press the top of the switch to activate the electric lift and raise the bed.
 - b. Press the bottom of the switch to lower the bed back into place.
7. Close and latch the tailgate.

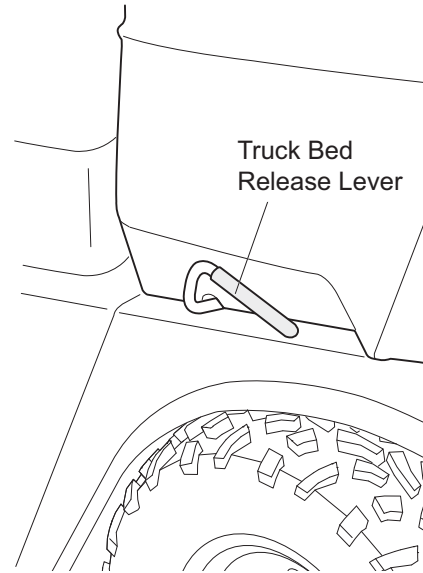

TOWING

NOTICE: Vehicles must be equipped with a rear hitch to tow a load.

⚠ WARNING

Attach a trailer to the tow hitch only. Attaching the trailer at any other location can cause loss of vehicle control.

Do not attach baskets or extensions to the hitch receiver. These types of items change the performance qualities of the vehicle and cause dangerous handling characteristics, possible rollover or vehicle damage.

When towing a load, follow these guidelines:

- Do not tow more than the recommended towing weight for the vehicle. See the following table and the *VEHICLE SPECIFICATIONS* on page 39.

VEHICLE LOADING	MAX. WEIGHT
Occupant Capacity	400 lbs (181.4 kg)
Cargo Capacity	400 lbs. (180 kg)
Vehicle Rated Capacity = Occupant + Cargo	800 lbs. (360 kg)
VEHICLE WEIGHT	
Curb Weight (includes batteries)	803 lb (364 kg)
Gross Weight = Curb Weight + Rated Capacity	1,603 lbs. (727 kg)
VEHICLE TOWING (0% - 20% GRADE)	
Drawbar Pull	475 lb (215 kg)
Maximum Trailer Tongue Weight	150 lbs (68 kg)
Maximum Gross Trailer Weight	900 lbs (408.2 kg)
Maximum Vehicle Combined Towing Weight = Curb Weight + Occupant Capacity + Trailer Weight	2,103 lbs. (954 kg)

- The total capacity of the vehicle, operator, passenger, load bed contents and accessories must be reduced to compensate for the trailer tongue load.
- The range of motion of the trailer is limited by the ball and hitch. Do not tow a trailer on rough terrain.
- Drive slowly and carefully.
- Towing a load increases braking distances required for slowing or stopping the vehicle.
- Do not attach baskets or extensions to the hitch receiver.
- Avoid parking on an incline.
- Do not operate on a grade exceeding 25%.
- Always secure the cargo

OPERATION

MAINTENANCE

MAINTENANCE SAFETY

WARNING

To prevent serious injury or death, follow the procedures and comply with the safety information in this manual while performing vehicle service or maintenance.

Use the tools shown in the tool list and wear the specified safety equipment when performing vehicle service or maintenance.

Remove all jewelry before you service the vehicle.

Do not allow loose clothing or hair to contact the moving parts.

Do not touch hot objects.

Make sure that the key switch is in the OFF position and the run/tow switch is in the TOW/STORAGE position before you start to work on the vehicle.

Disconnect the negative battery terminal before you service the vehicle to prevent accidental operation.

The drive wheels must be lifted and supported on jack stands before you do any service to the powertrain when the motor is in operation.

Chock the wheels and support the vehicle with jack stands. NEVER get under a vehicle that is supported by a jack. Lift the vehicle according to the manufacturers instructions.

Wear a face shield when working around the battery pack.

Be careful when working around batteries, using solvents or compressed air.

Use insulated tools within the battery area to prevent sparks or battery explosion.

To prevent the risk of battery explosion, keep all flammable materials, open flames or sparks away from the battery.

Maintain constant awareness that some components are heavy, spring loaded, corrosive, explosive, can cause high amperage or get extremely hot.

After you make repairs or do maintenance, test the vehicle in a safe area that is free from vehicle and pedestrian traffic.

NOTICE: *To decrease the risk of damage to the controller or motor, move the run/tow switch to the TOW position before you tow the vehicle.*

After you connect a battery or any other wires, wait a minimum of 30 seconds before you move the switch to the RUN position.

SCHEDULED MAINTENANCE

Consistent inspection, adjustment and lubrication of some components are necessary to maintain your *vehicle* so that it remains in safe and reliable condition. Refer to the *SCHEDULED MAINTENANCE CHART* on page 28 for detailed requirements.

Inspect, clean, lubricate, adjust and replace parts as necessary. Use OEM or equivalent replacement parts.

Record the maintenance items performed along with details in the *MAINTENANCE LOG* beginning on page 41.

NOTICE: *Service and adjustments are important for safe and reliable vehicle operation. If not familiar with safe service and adjustment procedures, have your dealer perform the operations.*

Severe Use Conditions

Vehicles subjected to heavy or severe use must be inspected and serviced more frequently than those of normal use patterns. The following conditions are considered severe use:

- frequent or prolonged use in a dusty environment
- frequent use in mud, water or sand
- prolonged low speed operation
- short trips in cold weather
- prolonged heavy load operation

MAINTENANCE

SCHEDULED MAINTENANCE CHART

Perform all services at the maintenance interval reached first.

S – Indicates operations that need to be performed on vehicles subjected to severe use.

Item	Interval (perform at interval that comes first)		Remarks	Page
	Hours	Calendar		
Overall vehicle condition	Pre-ride		Inspect.	
Battery Module	Daily		Charge daily after use.	
Steering	Pre-ride		Check for smooth and free operation.	
Front suspension	Pre-ride		Inspect. Check for leaks and loose or missing hardware.	
Rear suspension	Pre-ride		Inspect. Check for leaks and loose or missing hardware.	
Tires	Pre-ride		Check condition and pressure.	7
Wheel lug nuts	Pre-ride		Check for loose or missing.	32
Accelerator	Pre-ride		Check for smooth operation.	35
Brake system	Pre-ride		Check for smooth operation and acceptable stopping distance.	35
Frame hardware	Pre-ride		Check for loose or missing.	
Headlights and taillights	Pre-ride		Check operation. Replace bulbs as needed.	33
Reverse warning alarm	Pre-ride		Check operation.	
Switches	Pre-ride		Check operation.	
Fluid leakages	Pre-ride		Inspect entire vehicle for leaks	
S Brake shoes	10	Monthly	Inspect. Replace as needed.	
Charger receptacle	20	Monthly	Clean connections.	
Parking brake	20	Monthly	Conduct brake performance test; adjust as necessary. Check for correct hold on an incline.	
Accelerator	20	Monthly	Check for smooth operation.	
Wiring	20	Monthly	Inspect for loose connections, broken or missing insulation.	
Steering	20	Monthly	Check for excess play, loose or missing hardware.	
S Tie rods	20	Monthly	Check for excess play, bent rods, loose or missing hardware.	
Front suspension	20	Monthly	Inspect strut for leaks. Check hubs and kingpins, for excessive play, worn bushings, loose or missing hardware.	
Rear axle	20	Monthly	Check for leakage; add oil as required.	
Brakes	20	Monthly	Check for smooth operation and acceptable stopping distance.	35
Front wheel alignment	60	3 Months	Check for unusual tire wear.	
Rear Suspension	60	3 Months	Check for shock oil leakage, worn bushings, loose or missing hardware.	
S General lubrication	50	3 Months	Lubricate all fittings, pivots, cables, etc. where required.	29
Rear axle	500	5 years	Replace fluid.	
Motor coupling	20,000 Amp Hours	5 years	Add anti-seize compound (approx. 1 tbsp.)	

RECOMMENDED LUBRICANTS AND FLUIDS

Check and lubricate all components at the intervals shown in the *SCHEDULED MAINTENANCE CHART* beginning on page 28.

Item	Capacity	Lubricants/Fluids	Notes
Rear axle oil	25 oz. (0.7 L)	Mobil 424	Part Number 603967
Rear axle oil	2.0 oz (59 mL)	Friction Modifier E-Z-GO	Part Number 611242
Grease fittings		Universal joint grease or equivalent	Do not exceed 3 pumps of grease in each fitting.

REPLACEMENT OF MAINTENANCE ITEMS

These items or their equivalents can be purchased through your dealer or from any other qualified source.

Item	Part Number
58V, 10A Mini Fuse	636455G22
32V, 15A Mini Fuse	636455G13
32V, 5A Mini Fuse	636455G10
32V, 10A Mini Fuse	636455G12
Throttle Resistor	662004
12V, 20A Relay	643691
LED Headlight Assembly	651411G03
Headlight Bulb	619100
Turn Signal Bulb	619102
Taillight Bulb	21759G1

MAINTENANCE

LIFTING THE VEHICLE

WARNING

Read and comply with all of the following warnings and lifting procedures to prevent the possibility of the vehicle falling and causing serious injury or death.

For some maintenance procedures, it is necessary to lift the vehicle. Comply with the following warnings and follow the lifting procedure to ensure the safety of you, your vehicle and surroundings.

WARNING

The vehicle must be on a firm and level surface for lifting.

Remain constantly aware that the vehicle is not stable during the lifting process.

Place the jack and jack stands only in the areas indicated in the following illustration.

Do not get under a vehicle until it's stability on the jack stands is verified; never get under a vehicle while it is on a jack only.

Put wheel chocks in front and behind all wheels that are not being lifted.

Do not allow anyone to remain or get on the vehicle at any time during the lifting process or when the vehicle is lifted.

When performing any service to the drive-train, lift drive wheels off the ground.

Tools

- jack
- jack stands (4)
- wheel chocks

Lifting Front

1. Chock the rear wheels to keep the vehicle from rolling backward.
2. Put a jack under the center of the front axle.
3. Raise the vehicle with the jack.
4. Install a jack stand under the front frame cross member as shown.
5. Lower the vehicle until it rests on the jack stands.
6. Remove the jack.
7. Confirm that the vehicle is stable on the jack stands before proceeding with any service.

Lifting Rear

1. Chock the front wheels to keep the vehicle from rolling forward.
2. Put a jack under the center of the rear frame cross member.
3. Raise the vehicle with the jack.
4. Install a jack stand under each end of the rear axle.
5. Lower the vehicle until it rests on the jack stands.
6. Remove the jack.
7. Confirm that the vehicle is stable on the jack stands before proceeding with any service.

Lowering Vehicle

1. Make sure chocks are still in place on any wheels that remain on the ground.
2. Put the jack in the same location that was used to raise the vehicle.
3. Raise the vehicle enough to remove the jack stands. Remove the jack stands from underneath the vehicle.
4. Slowly lower the vehicle to the ground and remove the jack.

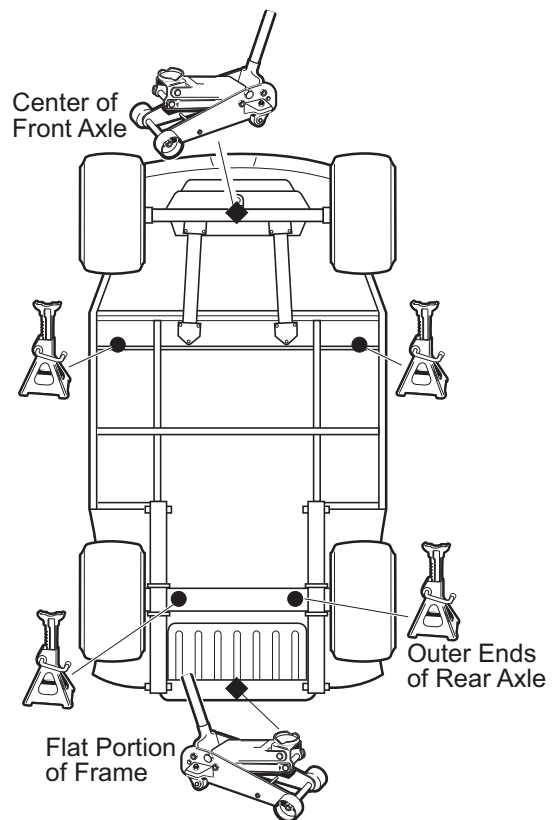

VEHICLE CLEANING AND CARE

Keeping your vehicle clean is not only beneficial to its appearance, but can also help extend the life of various components.

Washing the Vehicle

NOTICE: Do not use a pressure washer to wash your vehicle. High water pressure can damage components.

Some products, including insect repellents and chemicals, will damage plastic surfaces. Do not allow these types of products to contact the vehicle.

- Do not use a pressure washer to clean the vehicle.
- Use an automotive type cleaner or mild soap to wash the vehicle. Harsh cleaners can scratch the finish.
- Use clean or new cloths and pads for washing. Reused cloths and pads can contain dirt particles that will scratch the finish.
- Inspect all grease fittings for dirt intrusion or lack of grease after washing. Apply grease as required to maintain proper function.
- Use a sponge or soft brush and a soap/water solution to clean the vinyl seats. Rinse with clean water.
- Use an automotive type wash cloth to wash the body of the vehicle. To prevent the soap from drying on the vehicle, rinse with clean water frequently.
- Clean the windshield with water and a clean cloth. Remove small scratches with a plastic polish.
- Clean the bottom of the vehicle where mud or dirt can collect. Loosen any packed sediment to help with removal. Be careful not to damage the paint.
- Dry the vehicle with a chamois before the water dries to prevent water spots.

Polishing the Vehicle

- Do not use medium to heavy duty compounds on the finish. Use wax that is for clear coat automotive finishes only. Do not apply wax or polish to matte finish surfaces.
- Use clean or new cloths and pads for polishing. Old or reused cloths and pads can contain dirt particles that will scratch the finish.

TIRES

Follow the tire maintenance procedures as instructed in this manual and on the labels on the vehicle.

Always use approved size and type of replacement tires. See *VEHICLE SPECIFICATIONS* on page 39.

WARNING

Worn, improperly inflated, improper sized, or incorrectly installed tires will affect vehicle handling and could cause an accident resulting in severe injury or death.

Inflate all tires to the same pressure. Operating with unequal or incorrect pressure can adversely affect steering and handling and could cause an accident resulting in severe injury or death.

To decrease the risk of tire explosion, do not exceed the tire inflation rating on the tire sidewall. Make sure the tires are properly inflated at all times of operation. See *Tire Pressure* on page 32.

To decrease the risk of tire explosion, inflate small amounts of air into the tire at intervals to allow the beads to seat properly. Because of the low volume of the small tires, over inflation can occur in seconds. Never exceed the tire inflation pressure rating on the tire sidewall when seating a bead. Protect your face and eyes when you remove a valve core.

When you remove the wheels, use only sockets made for impact wrenches to decrease the risk of injury by a broken socket.

Do not use tires with low rated pressure. Do not use tires that have a recommended tire inflation pressure less than the tire inflation pressure recommended in the owner's guide.

Do not over inflate the tires. Excess pressure can cause the tire to separate from the wheel or cause a tire explosion.

MAINTENANCE

Tire Pressure

Maintaining correct tire inflation pressure is essential for safe vehicle operation. You can vary the inflation pressure, within the recommended range to suit the condition of the terrain.

TIRE PRESSURE RANGE	TERRAIN CONDITIONS	RECOMMENDATION
18 - 22 psi (124 - 152 kPa)	hard surfaces or pavement	Inflate to higher pressure within the range; never exceed maximum pressure indicated.
	soft terrain or turf	Inflate to lower pressure within the range to reduce potential damage to the terrain or turf.

Tire Repair

Tools

- lug wrench, 3/4"
- impact wrench
- impact socket, 3/4"
- torque wrench, ft.lbs.

NOTICE: Tire plug tools and plugs are available at automotive outlets. The tire does not have to be removed from the wheel to install the tire plug.

Use a tire plug to repair small holes in the tread part of the tire. For large holes or holes/cuts in the tire sidewall, the tire must be replaced.

1. Remove the wheel from the vehicle. See *Wheel Removal* on page 32.
2. Locate the leak in the tire.
 - a. If the tire is very low or flat, fully inflate the tire.
 - b. Brush soapy water over the surface of the tire. Air bubbles will be visible where the air is leaking from the tire.
 - c. Mark the hole with chalk.
3. Install the plug according to the manufacturer's instructions.
4. Install the wheel on the vehicle. See *Wheel Installation* on page 33.
5. Fully inflate the tire. See *Tire Pressure* on page 32.

Tire Replacement

Tire replacement requires a tire mounting machine and must be done by a qualified tire center or your TSV dealer.

WHEELS



WARNING

Worn, improperly inflated, improper sized, or incorrectly installed tires will affect vehicle handling and could cause an accident resulting in severe injury or death.



CAUTION

To decrease the risk of component damage, do not tighten the lug nuts to more than the torque specified below.

Check lug nuts for tightness at the intervals indicated in the *SCHEDULED MAINTENANCE CHART* on page 28.

Wheel Removal

Tools

- lug wrench, 3/4"
- impact wrench
- impact socket, 3/4"
- torque wrench, ft. lbs.

1. Lift the vehicle. See *LIFTING THE VEHICLE* on page 30.
2. Remove the lug nuts.
3. Remove the tire from the vehicle.

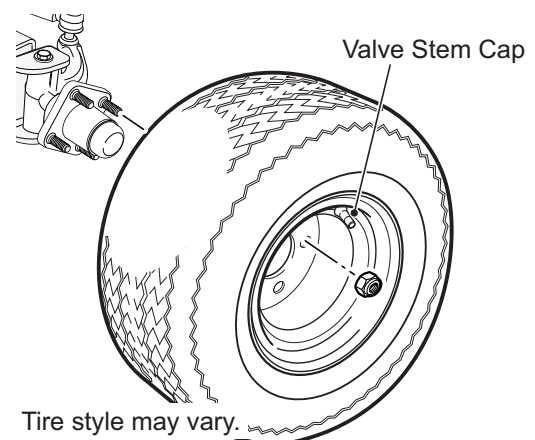

Wheel Installation

Lug Nut Torque	65 - 85 ft.lbs. (88 - 115 Nm)
----------------	-------------------------------

NOTICE: To decrease the risk of component damage, do not tighten the lug nuts to more than the specified torque.

Always install lug nuts using a cross sequence pattern to ensure even seating of the wheel against the hub.

1. Install the wheel on the hub with lug nuts. Make sure the valve stem is to the outside.
2. Finger tighten the lug nuts.
3. Using the tightening pattern shown at right, tighten the lug nuts to 65 - 85 ft.lbs. (88 - 115 Nm). Tighten in increments of 20 ft. lbs. (27 Nm).

Lug Nut Tightening Pattern

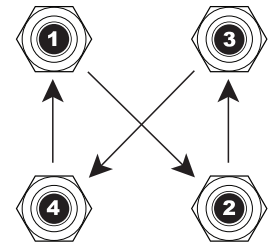

LIGHTS

- Clean the lights frequently to maximize visibility.
- Replace burned out bulbs promptly.

CAUTION

Do not operate this vehicle at night or in low light if any bulbs are burned out. Poor lighting reduces visibility that could cause an accident resulting in severe injury or death.

NOTICE: Replacement bulbs are available from a local distributor, an authorized branch or the service parts department.

Halogen Headlight Bulb Replacement

CAUTION

Light components can get hot if they have been in operation. Allow the lights to cool before servicing to prevent burns to the skin.

NOTICE: Do not touch a halogen bulb with bare fingers. Oil from skin leaves a residue that causes a hot spot and will diminish the life of the bulb.

1. Disconnect the headlight harness from the headlight.
2. Rotate the bulb 1/4-turn to remove the headlight from the housing.
3. Insert and rotate the new bulb to lock into place.
4. Connect the harness to the bulb.

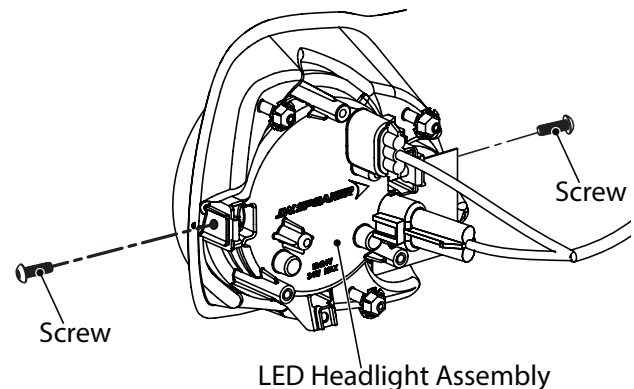

LED Headlight Assembly Replacement

1. Disconnect the headlight harness from the headlight.
2. Remove the screws securing the headlight assembly to the headlight bezel.
3. Remove the headlight assembly and install the new one with screws.
4. Connect the harness to the headlight assembly.

LED Taillight/Brake Light

1. Disconnect the tail light harness from the tail light.
2. Press the tail light assembly out of the grommet by pushing on the back of the assembly.
3. Press the new tail light assembly into the grommet.
4. Connect the harness to the tail light assembly.

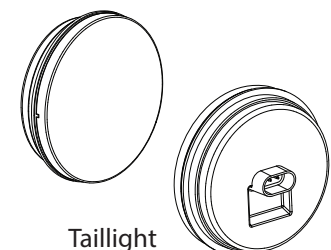

MAINTENANCE

FUSE REPLACEMENT

NOTICE: Have the vehicle inspected by your dealer if fuses continue to blow after they have been replaced.

1. Lift the seat bottom to access the PDM.
2. Open the PDM to access the fuses.
3. Remove the old fuse and replace with a new fuse of the same type and size.
4. Fuses are available from a local Distributor, an authorized Branch or the Service Parts Department.

CONTROLLER SYSTEM TEST

At monthly intervals, test the controller by allowing the vehicle to roll down an incline with the accelerator pedal released. Braking force should be felt at approximately 2 mph (3 kph) indicating that the system is functioning. If vehicle speed continues to rise, apply the brake and have vehicle inspected by a trained mechanic.

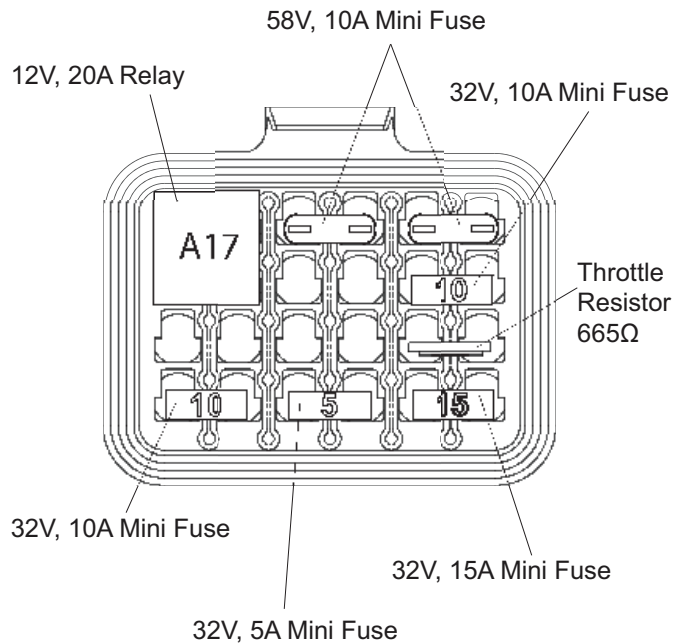

REAR AXLE

The only maintenance necessary for the first five years is the inspection of the rear axle for lubricant leakage. Unless leakage is visible, the lubricant needs to be replaced after five years. Refer to the Service and Repair Manual for the fluid replacement procedure.

Change the axle oil at the intervals indicated in the *SCHEDULED MAINTENANCE CHART* on page 28.

Checking the Lubricant Level

Clean the area around the check/fill plug and remove the plug. The correct lubricant level is just below the bottom of the threaded hole. If lubricant is low, add lubricant as required. Add lubricant slowly until lubricant starts to seep from the hole. Install the check/fill plug. In the event that the lubricant is to be replaced, the oil pan must be removed or the oil siphoned through the check/fill hole.

LUBRICATION

CAUTION Do not use more than three pumps of grease in a grease fitting at any one time. Excess grease can cause grease seals to fail, or allow grease into areas that could damage components.

Putting more than three pumps of grease in a grease fitting could damage grease seals and cause premature bearing failure.

Lubricate components at the intervals indicated in the *SCHEDULED MAINTENANCE CHART* on page 28.

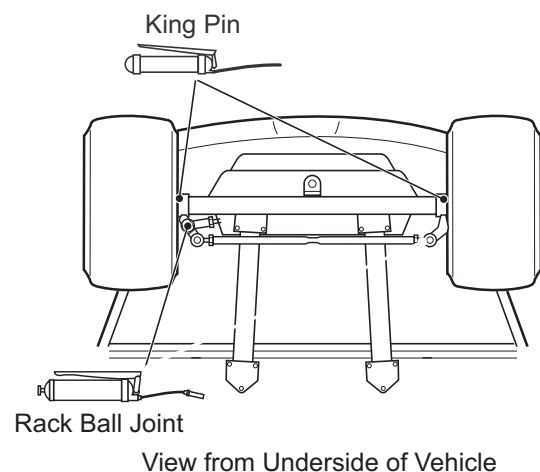

BRAKES



WARNING Always inspect the pedal travel before you operate a vehicle to confirm some brake function is present.

All driving brake tests must be done in a safe location with regard for the safety of all personnel.

NOTICE: Over time, a subtle loss of performance may take place; therefore, it is important to establish the standard with a new vehicle.

Test and service the brake system at the intervals indicated in the *SCHEDULED MAINTENANCE CHART* on page 28.

Periodic Brake Test

The *Periodic Brake Test* must be performed initially and regularly as an evaluation of your vehicle's brake system performance. It is a method of identifying subtle loss of braking performance over time.

Establish the 'acceptable stopping distance' when your vehicle is new and the brakes are at their peak of performance. As your vehicle is used, a subtle loss of braking performance may be detected, so it is important to establish the standard with a new vehicle.

Actual stopping distances are influenced by weather conditions, terrain, road surface condition, vehicle weight and speed. No specific braking distance can be reliably specified, so it is important to establish a base to test with.

The test is conducted by engaging the park brake instead of the brake pedal to eliminate different pedal pressures, to include affects of linkage mis-adjustment and provide a more accurate test.

NOTICE: You must have enough space to accelerate to maximum speed before engaging the parking brake. Use a marker to indicate the predetermined line to engage the parking brake that you will use for the performance test.

1. On a dry, level, clean, paved surface, accelerate the vehicle to maximum speed.
2. Engage the parking brake at the predetermined and marked line.
3. Mark the line where the vehicle comes to a complete stop.
4. If the vehicle stops in a significantly greater distance than the established distance in future tests, or pulls to one side, it should be tested again.
5. If the vehicle fails the second test, discontinue use until it can be inspected and determined safe for operation by a qualified mechanic.

NOTICE: If the vehicle is equipped with 4-wheel mechanical brakes and pulls to one side, the brake mechanisms must be adjusted. Refer to the repair and service manual for brake adjustment procedure.

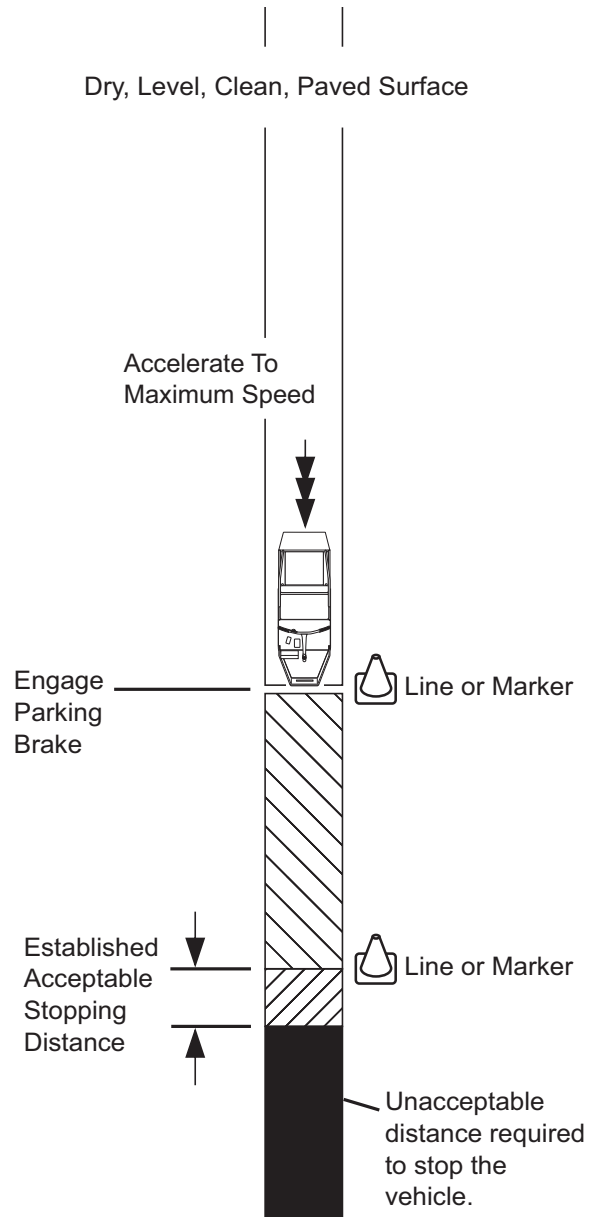

MAINTENANCE

LITHIUM-ION BATTERY PACK

Charge the battery pack using only the OEM approved Lithium-Ion battery charger.

WARNING

Improper handling of batteries and electrical components can result in serious injury or death.

Do not remove the battery pack cover. Do not attempt to remove batteries or battery cables. Do not use the battery pack without the control module installed. All battery and electrical service must be performed by an authorized service facility.

All tools used in or around the battery pack area should be insulated. Do not intentionally cause a short to the power terminal (P+, P-, B+, B-) with a metallic object.

Do not use the vehicle or charge the battery pack if the battery pack has become abnormally hot, is discolored, deformed, leaking or has an odd odor. If liquid from the battery pack leaks onto skin or clothes, wash well immediately with fresh, running water. If liquid gets into the eyes, do not rub the eyes. Wash the eyes with fresh, running water and seek medical assistance immediately.

Do not cut, tear or remove the seal tape. Do not disassemble or modify the design, including the electrical circuit, of the battery pack or control module.

To prevent the risk of battery explosion, keep all flammable materials, open flames or sparks away from the batteries. Do not leave the battery pack near a fire or heat source. Do not throw Lithium-Ion batteries into a fire. Do not apply heat to any part of the battery pack or battery management module with a soldering iron. Do not place the battery pack in a microwave oven, dryer or high-pressure container.

Make sure that the key switch is in the OFF position and the run/tow switch is in the TOW/STORAGE position before you start to work on the vehicle.

Do not attempt to operate the vehicle or charge the battery pack at temperatures above 140°F (60°C).

Do not immerse or throw the battery pack in water. Do not pressure wash the battery pack.

Do not puncture the battery pack or control module. Do not strike the battery pack with a hammer or heavy weight. Do not step or stand on the battery pack. Do not throw or drop the battery pack on hard surfaces.

If the battery pack terminals are contaminated or dirty, clean them with a dry cloth before using the battery pack.

Keep the battery pack and control module away from static electricity.

WARNING

Before recycling or shipping battery pack, make sure that the battery pack terminals are insulated.



Lithium-Ion batteries are recyclable:

- Return discarded batteries to distributor or manufacturer for recycling.
- Contact local or state environmental department for the disposal information.
- Refer to the Maintenance section for additional information.

BATTERY CHARGING AND MAINTENANCE

NOTICE: Do not spray the battery module with water. Do not attempt to add water to the battery module.

Do not charge the batteries if the ambient temperature is below -4°F (-20°C) or above 113°F (45°C). Refer to Appendix A for battery charger operating instructions.

Before connecting the battery charger:

- Park the vehicle, turn the key switch to OFF and remove the key.
- Inspect the charging receptacle for dirt or debris. Clean if necessary.
- Inspect the charger cords for cracks or damage. Replace any damaged cords before use.
- Plug the charger into a receptacle on a dedicated circuit. Do not connect any other devices to the receptacle.
- Connect the charger to the vehicle.

BATTERY CHARGING

The battery charger is designed to completely charge the battery set. The automatic charger determines the correct length of charge for the battery set and turns off when the batteries are charged. Always refer to the instructions supplied with the charger. See Appendix A for charger operating instructions.

BATTERY PROLONGED STORAGE

Improper storage may damage, destroy or cause permanent loss of battery capacity. Do not exceed storage time or temperature limits. Batteries must be charged to the correct level before storage. Storing fully depleted batteries will make them permanently unusable.

Storage Preparation

The optimum storage temperature range is between 65°F and 82°F (18°C and 28°C)

- Charge the battery module based on climate during storage period.
 - In cold climates, fully charge the battery module. Make sure that the charging operation is complete and there are no faults displayed on the charger. The green light on the charger should be on indicating the charge cycle is complete.
 - In hot climates, store the vehicle with a 30% to 50% charge of battery pack capacity.
- Turn the key to the OFF position and remove it from the key switch.
- Check the run - tow switch under the seat, make sure it is set in the TOW/STORAGE position.
- Turn off all accessories.

The storage time for properly charged Lithium-Ion batteries supplied with this vehicle varies based on the ambient temperature.

Temperature	Length of Storage Time
-22°F to -4°F (-30°C to -20°C)	One month at 30%-50% battery charge, all accessories turned off.
-4°F to 113°F (-20°C to 45°C)	Six months at 100% battery charge, all accessories turned off.
113°F to 140°F (45°C to 60°C)	One month at 100% charge, all accessories turned off.

BATTERY FAULT DIAGNOSIS

Refer to the charger instructions in Appendix A.

MAINTENANCE

TRANSPORTING THE VEHICLE

⚠ WARNING Do not ride or allow other people on a vehicle being transported on a trailer or being towed with another vehicle.

Towing the Vehicle

⚠ WARNING Do not try to tow the vehicle with ropes, chains or any device.

This vehicle is not designed to be towed.

Hauling the Vehicle

⚠ WARNING Loose cargo or vehicle components can fly off when the vehicle is being transported. Secure or remove all cargo. Inspect the vehicle for loose components prior to transport.

Do not allow any people on a vehicle being transported on a trailer.

Remove the windshield before you transport a vehicle on a trailer.

Maximum speed with canopy top installed is 50 mph (80 kph).

- If the vehicle is being hauled on a trailer or truck at highway speeds, the canopy top must be removed.
 - If the vehicle is being hauled on a trailer or truck below highway speeds, check that canopy top hardware is tight and there are no cracks in the canopy top at the mounting points.
 - The rated capacity of the hauling trailer or truck must be more than the weight of the vehicle and load plus 1000 lbs. (454 kg). See GENERAL SPECIFICATIONS for the weight of the vehicle.
1. Drive the vehicle onto the trailer or truck.
 2. Engage the parking brake.
 3. Turn the key switch to the OFF position. To prevent loss of the key, remove it from the ignition switch.
 4. Make sure the seats are secured.
 5. Secure the vehicle to the trailer or truck with tie downs, straps or ropes.

SPECIFICATIONS

VEHICLE SPECIFICATIONS

• Solid State continuously variable AC speed controller	• Full torque, reduced speed reverse
• Key Switch direction selector (Forward-Neutral-Reverse)	• Inductive throttle sensor
• Anti-roll back, walkaway braking and alarm	• Diagnostic indicator
• Anti-stall motor protection	• Factory programmable to application
• Regenerative 'Pedal Down' and/or 'Pedal Up' braking	
Motor: 48 Volt AC Induction, solid copper windings. Non vented 11.7 hp (8.7 kW) Continuous.	
Drive Train: Direct motor shaft connected to transaxle pinion shaft.	
Electrical System: Single, 48V Li-Ion Module.	
Transaxle: Differential with helical gears.	
Brakes: Dual rear wheel mechanical self-adjusting drum brakes. Automatic single point park brake release with self-compensating system.	
Item	Specification
Overall Length	110 in. (280 cm)
Overall Width	49 in. (125 cm)
Overall Height (No Canopy)	47 in. (120 cm) (Top of steering wheel)
Overall Height (With Canopy)	69.5 in. (176 cm)
Wheel Base	65.5 in. (166 cm)
Front Wheel Track	37 in. (94 cm)
Rear Wheel Track	38 in. (97 cm)
Ground Clearance (at Differential)	4.3 in. (11 cm)
Load Deck Width	44 in. (112 cm)
Load Deck Length	28 in. (71 cm)
Power Source	39.2 - 56.7 Volt Li-Ion Battery
Motor Type	AC Induction
Rated Power Output	11.7 hp (8.7 kW)
Electrical System	48 Volt Primary, 12 Volt Auxiliary
Batteries (Quantity, Type)	Single, 56.7 Max Vol Li-Ion Composite Module (Standard Configuration)
Key or Pedal Start	Pedal Start
Speed Controller	235 Amp AC
Drive Train	Motor Shaft Direct Drive
Transaxle	Differential with helical gears
Gear Selection	Key Switch Forward-Neutral-Reverse
Rear Axle Ratio	16.99:1
Seating Capacity	2 Person
Dry Weight	753 lb. (342 kg) (Without Batteries)
Curb Weight	800 lb. (363 kg)
Load Deck Capacity	400 lb. (181 kg)

SPECIFICATIONS

Vehicle Load Capacity	800 lb. (360 kg)
Outside Clearance Circle	18.9 ft. (5.76 m)
Speed (Level Ground)	16.5 mph \pm 0.5 mph (26.35 kph \pm 0.8 kph)
Towing Capacity	900 lbs (408 kg) max load
Steering	Self-compensating rack and pinion
Front Suspension	Leaf springs with hydraulic shock absorbers
Rear Suspension	Leaf springs with hydraulic shock absorbers
Service Brake	Rear wheel mechanical self-adjusting drum
Parking Brake	Self-compensating, single point engagement
Front and Rear Tires	K500 20 X 8 - 10 (6 Ply Rated)
Frame	Welded steel, DuraShield™ powder coat
Front Body and Finish	Injection Molded TPO
Standard Color	Forest Green
Noise	Sound pressure; continued A-weighted \leq 70 db(A)
Vibration, WBV	Highest RMS value of weighted acceleration is less than 1.92 m/s ² The uncertainty of measurement is 0.17 m/s ²
Vibration, HAV	Highest RMS value of weighted acceleration is less than 2.5 m/s ²
	Measurement methods were applied per the ISO 2631 and ISO 5349 standards under conditions of typical vehicle surfaces.
<i>Some items shown may be optional equipment</i>	

APPENDIX A

BATTERY CHARGER USER'S GUIDE



1 kW Industrial Battery Charger

QuiQ Charger - E-Z-GO Product Manual

This manual contains important safety and operating instructions for versions of the Delta-Q QuiQ (Model nos. 913-4830-E3/-E3B/-E5 /-E5B) installed on E-Z-GO brand vehicles. Please read this information before using your QuiQ Charger. For manufacturer contact information and technical support resources, please visit delta-q.com/support



SAVE THESE IMPORTANT SAFETY INSTRUCTIONS - This manual contains important safety and operating instructions – read before using charger.



Warning

Charge only 48 Volt Lithium-Ion type batteries activated by Samsung SDI. Other types of batteries may burst causing personal injury and damage. Never charge a frozen battery. Study the battery manufacturer's specific precautions.



Danger

Risk of electric shock. Connect charger power cord to an outlet that has been properly installed and grounded in accordance with all local codes and ordinances. A grounded outlet is required to reduce risk of electric shock – do not use ground adapters or modify plug. Do not touch uninsulated portions of output connector or uninsulated battery terminals. Disconnect the charger from either the AC supply or from the golf cart, before making or breaking the connections to the battery. Do not open or disassemble charger. Do not operate this charger if the AC supply cord is damaged or if the charger has received a sharp blow, been dropped, or is damaged in any way – refer all repair work to the manufacturer, or qualified personnel. This charger is not intended for use by persons (including children) with reduced physical, sensory or mental capabilities, or lack of experience and knowledge on electrical systems and battery charging, unless they have been given supervision or instruction concerning use of the charger by a person responsible for their safety. Children should be supervised to ensure that they do not play with the charger.

INFORMATIONS IMPORTANTES DE SÉCURITÉ Ce manuel contient des instructions importantes concernant la sécurité et le fonctionnement.



Attention

Recharger uniquement les batteries de type Lithium-Ion 48V activées par Samsung SDI. Autres types de batteries pourraient exploser causant des blessures corporelles et des dommages. Ne jamais charger une batterie gelée. Prendre connaissance des mesures de précaution spécifiées par le fabricant de la batterie.



Danger

Risque de décharge électrique. Ne pas toucher les parties non isolées du connecteur de sortie ou les bornes non isolées de la batterie. Toujours connecter le chargeur à une prise de courant mise à la terre. Déconnectez la source AC avant de faire ou défaire les connexions à la batterie en chargement. Ne pas utiliser le chargeur si le cordon d'alimentation AC est endommagé ou si le chargeur est abîmé suite à une chute ou autre indicent. Ne pas ouvrir ni désassembler le chargeur – référer toute réparation aux personnes qualifiées. Cet appareil n'est pas destiné à un usage par des personnes (dont les enfants) avec des facultés motrices, sensorielles ou mentales réduites, ou ayant une expérience et des connaissances insuffisantes, à moins qu'elles sont sous la supervision ou reçoivent les instructions sur l'utilisation de l'appareil d'un répondant garant de leur sécurité. Les enfants devraient être surveillés afin qu'il ne jouent en aucun temps avec l'appareil.

Maintenance Instructions

1. Do not expose charger to high pressure water spray when cleaning vehicle.
2. The enclosure of the charger meets IP66, making it dust-tight and protected against powerful water jets. The AC connection is rated to IP20, which is not protected against water. Protect the AC connection if used in wet or dusty environments.
3. If the detachable input power supply cord set is damaged, replace with a cord that is appropriate for your region:
 - ✦ This charger is provided with a cord set for connection to outlets operating at nominal 120 Volts (or 240 Volts as appropriate). If the input plug does not fit the power outlet, contact Delta-Q Technologies for the proper cord set terminating in an attachment plug of the proper configuration for the power outlet.
 - ✦ 'North America: UL or CSA listed / approved detachable cord, 3 conductor, 16AWG minimum and rated SJT; terminated in a grounding type IEC 60320 C14 plug rated 250V, 13A minimum
 - ✦ For all other regions: Safety approved detachable cord, 3 conductor, 1.5mm² minimum, rated appropriately for industrial use. The cord set must be terminated on one end with a grounding type input connector appropriate for use in the country of destination and, on the other end, an output grounding type IEC 60320 C14 plug.

Operating Instructions

CAUTION: Charger enclosure may be hot during charging. Use hand protection if handling the charger while charging.

- + Extension cords must be 3-wire cord no longer than 30m(100') at 10AWG or 7.5m(25') at 16AWG per UL guidelines.
- + Only connect ONE QuiQ charger to a single 15A circuit or the circuit may become overloaded.

Ammeter

Displays scale of output current

- + If only ammeter and AC Indicator LEDs are lit: Less than 80% state of charge
- + If flashing: Output has been reduced due to high internal charger temperature.

Charger 10-LED Display

Charge Indicator (Orange Light)

- + If solid: Greater than 80% state of charge
- + If off: Less than 80% state of charge or pre-charge

Charge Completion Indicator (Green Light)

- + If solid: Charging is complete

AC Indicator (Orange Light)

- + If solid: AC power is present.
- + If flashing: Low AC voltage. Check electrical source and cord length.

Fault Indicator (Red Light)

- + Charger error. Refer to troubleshooting information below.

Receptacle Display

LED	Indication
Solid	Charge complete
Long flash	Greater than 80% state of charge
Short flash	Less than 80% state of charge
Off	See charger for indications.

Troubleshooting Instructions

If a fault occurs, count the number of red flashes between pauses and refer to the table below.

Flashes	Cause	Solution
⏸️ 🔴 🔴 ⏸️	Charger unable to apply wake-up pulse	Refer cart to service department
⏸️ 🔴 🔴 🔴 🔴 ⏸️	Charge timeout	Possible BMS error - refer cart to service department
⏸️ 🔴 🔴 🔴 🔴 🔴 ⏸️	BMS fault	Refer cart to service department
⏸️ 🔴 🔴 🔴 🔴 🔴 🔴 ⏸️	Charger shutdown due to high internal temperature.	Ensure sufficient cooling airflow. Reset the charger by interrupting AC power for 15+ seconds.
⏸️ 🔴 🔴 🔴 🔴 🔴 🔴 🔴 ⏸️	Internal charger fault	Reset the charger by interrupting AC power for 15+ seconds. Return to service department if fault persists.

Note: This is a Class A product. In a domestic environment this product may cause radio interference, in which case the user may be required to take adequate measures.

APPENDIX A

APPENDIX B

BATTERY CHARGER USER'S GUIDE

ELiTE



RC900 ELiTE Onboard Charger Original User Manual

This manual contains important safety and operating instructions for this version of the Delta-Q RC900 ELiTE Onboard Charger (Part No. 944-0003) for use with E-Z-GO ELiTE lithium brand vehicles (Model 673928). For manufacturer contact information and technical support, please visit <http://support.delta-q.com/>.

SAVE THESE SAFETY INSTRUCTIONS
This manual contains important safety & operating instructions. Read before using the charger.



Warning

Charge only 48V lithium-ion type batteries activated by Samsung SDI. Other types of batteries may burst causing personal injury and damage. The Samsung Battery Management System (BMS) ensures that in all operating modes, the battery cells are protected from inappropriate levels of voltage, current, temperature, and state of charge. Never charge a frozen battery. Study the battery manufacturer's specific precautions before using this charger.



Danger

Risk of electric shock. Connect charger power cord to an AC outlet that has been properly installed and grounded in accordance with all local codes and ordinances. A grounded AC outlet is required to reduce the risk of electric shock—do not use ground adapters or modify the plug. Do not touch uninsulated portions of the output connector or uninsulated battery terminals. Disconnect the AC supply before making or breaking the connections to the battery. Do not open or disassemble the charger. Do not operate this charger if the AC supply cord or DC output cord is damaged or if the charger is damaged in any way. Refer all repair work to the manufacturer, or qualified personnel. This charger is not intended for use by persons (including children) with reduced physical, sensory or mental capabilities, or lack of experience and knowledge on electrical systems and battery charging, unless they have been given supervision or instruction concerning use of the charger by a person responsible for their safety. Children should be supervised to ensure they do not play with the charger.

Manuel d'origine de l'utilisateur du Chargeur À bord RC900 ELiTE

Le présent manuel contient d'importantes consignes de sécurité et d'utilisation pour cette version du chargeur Delta-Q à bord RC900 ELiTE (numéro de référence 944-0003) pour utilisation avec les véhicules de marque E-Z-GO ELiTE alimentés par des batteries au lithium-ion (Modèle 673928). Pour les coordonnées et le soutien technique du fabricant, visitez <http://support.delta-q.com/>.

CONSERVEZ CES CONSIGNES DE SÉCURITÉ
Le présent manuel contient d'importantes consignes de sécurité et d'utilisation. Lisez-les avant d'utiliser le chargeur.



Attention

Chargez uniquement les batteries au lithium-ion 48 V activées par Samsung SDI. Les autres types de batteries pourraient exploser causant des blessures corporelles et des dommages. Le système de gestion des batteries intégrés (BMS) garantit que dans tous les modes de fonctionnement, les cellules de la batterie sont protégées contre les niveaux inappropriés de tension, de courant, de température et d'état de charge. Ne chargez jamais une batterie gelée. Prenez connaissance des mesures de précaution spécifiées par le fabricant de la batterie avant d'utiliser ce chargeur.



Danger

Risque de décharge électrique. Toujours connecter le cordon d'alimentation du chargeur à une prise de secteur CA proprement installée et mise à la terre conformément à tous les codes et règlements locaux.. Une prise secteur CA mise à la terre est nécessaire pour réduire le risque de choc électrique - n'utilisez pas d'adaptateurs de terre et ne modifiez pas la fiche. Ne pas toucher les parties non isolées du connecteur de sortie ou les bornes non isolées de la batterie. Déconnectez la source CA avant de faire ou défaire les connexions à la batterie en chargement. Ne pas ouvrir ni désassembler le chargeur. Ne pas utiliser le chargeur si le cordon d'alimentation CA ou le cordon de sortie CC est endommagé ou si le chargeur est abîmé suite à une chute ou autre incident – Référez toute réparation au fabricant ou aux personnes qualifiées. Cet appareil n'est pas destiné à un usage par des personnes (dont les enfants) avec des facultés motrices, sensorielles ou mentales réduites, ou ayant une expérience et des connaissances insuffisantes, à moins qu'elles sont sous la supervision ou reçoivent les instructions sur l'utilisation de l'appareil par une personne responsable de leur sécurité. Les enfants doivent être surveillés afin qu'il ne jouent en aucun temps avec le chargeur.

Operating & Maintenance Instructions

- ❖ The charger may become hot during charging. Do not touch the charger when it is charging.
- ❖ To maintain safe operations, the unit automatically reduces its output power if the temperature rises above set thresholds, or if the AC input voltage is too low. The charger also reduces output power if it detects the battery pack is damaged.
- ❖ If power is interrupted, and then returns, the charger starts and continues to operate without hazard to the user, or damage to the batteries.
- ❖ Unplug the charger from AC when cleaning, moving, or conducting any maintenance or repair on the vehicle. No user serviceable parts are inside the charger. Do not remove the charger or the cover due to the risk of electrical shock.
- ❖ Do not expose the charger to oil, dirt, mud, or direct heavy water spray when cleaning the vehicle or machine.
- ❖ The enclosure on these chargers meets IP56, making it protected from dust ingress and powerful water jets. The AC receptacle requires an external AC cord which is not protected against dust or water. Protect this AC connection if the charger is used in wet or dusty environments. Inspect it regularly for contamination. If the charger and/or cord are in a damp location, use a Class A GFCI AC outlet.
- ❖ If the detachable AC input power cord or DC output cord is damaged, do not use the charger until they are replaced by a qualified service technical with cord sets appropriate to your region and application.
- ❖ To charge your vehicle, use a 3-wire extension cord less than 30m (100') at 10 AWG or 7.5m (25') at 16 AWG, per UL guidelines.

AC Receptacle Indicators

LED	Indication
Off	No AC Power. Check for AC cord damage; plug into AC power outlet; ensure AC outlet has power.
Slow Green Breathing	More than 80% state of charge.
Fast Green Breathing	Less than 80% state of charge.
Solid Green	Charge Complete
Rapid Amber Flash	Error. Unplug and plug the charger in again. If the error remains, contact a qualified service technician.
Solid Red	Fault. Unplug and plug the charger in again. If the fault remains, contact a qualified service technician.

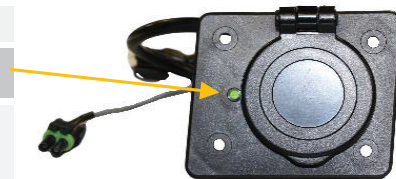

Identifying Charger Serial Number

The serial number is printed on the front of the charger. Use this number when requesting technical support.



NOTE: This equipment has been tested and found to comply with the limits for a Class B digital device, pursuant to Part 15 of the FCC/ICES Rules. These limits are designed to provide reasonable protection against harmful interference in a residential installation. This equipment generates, uses, and can radiate radio frequency energy and, if not installed and used in accordance with the instructions, may cause harmful interference to radio communications.

Delta-Q Technologies Corp.
 3755 Willingdon Ave.
 Burnaby, B.C. V5G 3H3 CANADA
 Phone: +1.604.327.8244

Email: support@delta-q.com
 Web: www.delta-q.com
 User Documentation: www.delta-q.com/resources

APPENDIX B

APPENDIX C

BATTERY CHARGER USER'S GUIDE

ELiTE

Lithium Golf Cart
Battery Charger



Chargeur de batterie au lithium
pour chariot de golf

E-Z-GO ELiTE Charger Original User Manual

This manual contains important safety and operating instructions for these versions of the Delta-Q ELiTE Charger (Part Nos. 958-0001, 958-0002, 958-0003, and 958-0004) for use with E-Z-GO ELiTE lithium brand vehicles. Read this information in its entirety before using your ELiTE Charger. For manufacturer contact information and technical support, visit <http://support.delta-q.com/>.

SAVE THESE SAFETY INSTRUCTIONS
This manual contains important safety & operating instructions. Read before using the charger.

Warning

Charge only 48V lithium-ion type batteries activated by Samsung SDI. Other types of batteries may burst causing personal injury and damage. Never charge a frozen battery. Study the battery manufacturer's specific precautions before using this charger.

Danger

Risk of electric shock. Connect charger power cord to an AC outlet that has been properly installed and grounded in accordance with all local codes and ordinances. A grounded AC outlet is required to reduce risk of electric shock – do not use ground adapters or modify the plug. Do not touch uninsulated portions of the output connector or uninsulated battery terminals. Disconnect the AC supply before making or breaking the connections to the battery. Do not open or disassemble the charger. Do not operate the charger if the AC supply cord or DC output cord is damaged or if the charger has received a sharp blow, been dropped, or is damaged in any way. Refer all repair work to the manufacturer or qualified personnel. This charger is not intended for use by persons (including children) with reduced physical, sensory or mental capabilities, or lack of experience and knowledge on electrical systems and battery charging, unless they have been given supervision or instruction concerning use of the charger by a person responsible for their safety. Children should be supervised to ensure they do not play with the charger.

Manuel d'origine de l'utilisateur du Chargeur E-Z-GO ELiTE

Le présent manuel contient d'importantes consignes de sécurité et d'utilisation pour ces versions du Chargeur Delta-Q ELiTE (numéros de référence 958-0001, 958-0002, 958-0003, et 958-0004) pour utilisation avec les véhicules de marque E-Z-GO ELiTE alimentés au lithium. Lisez en entier les informations fournies avant d'utiliser le Chargeur ELiTE. Pour les coordonnées et le soutien technique du fabricant, visitez <http://support.delta-q.com/>.

CONSERVEZ CES CONSIGNES DE SÉCURITÉ
Le présent manuel contient d'importantes consignes de sécurité et d'utilisation. Lisez-les avant d'utiliser le chargeur.

Mise en garde

Chargez uniquement les batteries au lithium-ion 48 V activées par Samsung SDI. Les autres types de batteries pourraient exploser causant des blessures corporelles et des dommages. Ne chargez jamais une batterie gelée. Prenez connaissance des mesures de précaution spécifiées par le fabricant de la batterie avant d'utiliser ce chargeur.

Danger

Risque de choc électrique. Branchez le cordon d'alimentation du chargeur à une prise CA qui a été correctement installée et mise à la terre conformément à tous les codes et règlements locaux en matière d'électricité. Une prise CA mise à la terre est requise pour réduire les risques d'électrocution; n'utilisez pas d'adaptateurs de terre ou ne modifiez pas la fiche. Ne touchez pas la partie non isolée du connecteur de sortie ou les bornes de la batterie non isolées. Débranchez l'alimentation CA avant d'effectuer ou de rompre les connexions à la batterie. N'ouvrez pas ou ne démontez pas le chargeur. N'utilisez pas le chargeur si son cordon d'alimentation CA ou son cordon de sortie CC est endommagé ou si le chargeur a reçu un coup violent, s'il est tombé ou s'il a été endommagé de quelque façon que ce soit. Le chargeur ne doit être réparé que par le fabricant ou du personnel qualifié. Ce chargeur n'est pas conçu pour être utilisé par des personnes (y compris les enfants) ayant des capacités physiques, sensorielles ou mentales réduites, ou manquant d'expérience et de connaissances des systèmes électriques et de la charge de batteries, à moins qu'une personne responsable de leur sécurité ne les supervise ou ne leur ait fourni les consignes d'utilisation. Les enfants doivent être supervisés pour s'assurer qu'ils ne jouent pas avec le chargeur.

Maintenance Instructions

1. The enclosure on all charger models meets IP56, making it protected from dust ingress and powerful water jets. The AC connection on the 958-0002 and 958-0004 models requires an external AC cord and is rated to IP20, which is not protected against dust or water. Protect this AC connection if the charger is used in wet or dusty environments and inspect it regularly for contamination.
2. If the AC power supply cord is damaged:
 - The 958-0001 and 958-0003 charger models have an integral AC cord for connection to North American outlets operating at 120 Volts nominal. If this AC power supply cord is damaged, do not use the charger and send it to a qualified service technician for repair.
 - The 958-0002 and 958-0004 charger models have a 7-inch (185mm) AC cord terminated with an IEC 320 C14 plug. If this AC power supply cord is damaged, do not use the charger and send it to a qualified service technician for repair. If the mating AC cord to the wall outlet is damaged, replace it with a 6 feet (1.83 meter) long UL/CSA approved AC cord with a grounded IEC 320 C13 socket rated 250V, 13A minimum on the charger side and an approved 3-prong grounded plug compatible with the local AC power outlet (110VAC to 240VAC). If the 3-prong grounded plug does not fit the local AC power outlet, contact E-Z-GO or Delta-Q Technologies for the proper cord for the local AC power outlet.
 - For regions with 220-240V mains supply, select a safety approved AC cord, 3-conductor, 1.0mm² minimum, rated appropriately for industrial use. The cord must be terminated on one end with a grounded input connector appropriate for the AC power in the country of destination and, on the charger end, a grounding type IEC 320 C13 socket.

NOTE: This equipment has been tested and found to comply with the limits for a Class B digital device, pursuant to Part 15 of the FCC/ICES Rules. These limits are designed to provide reasonable protection against harmful interference in a residential installation. This equipment generates, uses, and can radiate radio frequency energy and, if not installed and used in accordance with the instructions, may cause harmful interference to radio communications.

Mounting Instructions

The charger can be mounted horizontally or vertically with the cables and LED indicators pointing downward. Five (5) robust mounting points are cast into the charger's aluminum enclosure and another mounting hole in the center of the handle. The charger can be screwed to a table or wall with the four (4) slotted mounting holes, two (2) on each side using M6 or ¼-inch fasteners. A vertical mounting from the single cast keyhole mounting slot opposite the cables is possible using a suitable 8 or 10mm or 3/8-inch J-hook. A suspended horizontal mounting is achieved using a ceiling secured 5/16-inch threaded rod secured with nuts above and below the handle.

Consignes d'entretien

1. Le boîtier en tout modèles de chargeur est conforme à la norme IP56, le protégeant ainsi contre l'infiltration de poussière et les jets d'eau puissants. Le branchement CA sur les modèles 958-0002 et 958-0004 nécessite un cordon CA externe et est conforme à la norme IP20, qui n'offre pas de protection contre la poussière ou l'eau. Protégez ce branchement CA si le chargeur est utilisé dans un environnement humide ou poussiéreux et inspectez le régulièrement pour déceler toute contamination.
2. Si le cordon d'alimentation CA est endommagé :
 - Les modèles de chargeur 958-0001 et 958-0003 sont équipés d'un cordon CA intégré pour le branchement sur les prises en Amérique du Nord fonctionnant à une tension nominale de 120 volts. Si ce cordon d'alimentation CA est endommagé, n'utilisez pas le chargeur et envoyez-le à un technicien de service qualifié pour la réparation.
 - Les modèles de chargeur 958-0002 et 958-0004 sont équipés d'un cordon d'alimentation CA de 7 pouces (185 millimètre) se terminant par une fiche IEC 320 C14. Si ce cordon d'alimentation CA est endommagé, n'utilisez pas le chargeur et envoyez-le à un technicien de service qualifié pour la réparation. Si le cordon d'alimentation CA d'accouplement à la prise murale est endommagé, remplacez le par un cordon d'alimentation CA approuvé UL/CSA de 6 pieds (1,83 m) de longueur avec une prise IEC 320 C13 reliée à la terre fonctionnant à une tension nominale de 250 V, 13A minimum au côté chargeur et une fiche mise à la terre approuvée à 3 broches compatible avec la prise de courant CA locale (110 V c.a. à 240 V c.a.). Si la fiche mise à la terre à 3 broches ne convient pas à la prise de courant CA locale, communiquez avec E-Z-GO ou Delta-Q Technologies pour connaître le cordon approprié pour la prise de courant CA locale.
 - Pour les régions utilisant une alimentation secteur 220-240 V, sélectionnez un cordon d'alimentation CA approuvé, à 3 conducteurs, 1,0 mm² minimum, évalué de façon appropriée pour une utilisation industrielle. Le cordon doit se terminer, à une extrémité, par un connecteur d'entrée mis à la terre approprié pour l'alimentation CA dans le pays de destination et, à l'autre extrémité du chargeur, par une fiche IEC 320 C13 mise à la terre.

REMARQUE: cet équipement a été testé et déclaré conforme aux limites pour appareils numériques de classe B, selon la section 15 des règlements de la FCC et de l'ICES. Ces limites sont destinées à assurer une protection raisonnable contre les interférences nuisibles dans une installation résidentielle. Cet équipement produit, utilise et peut émettre de l'énergie radio électrique et, s'il n'est pas installé et utilisé conformément aux présentes instructions, peut causer des interférences nuisibles aux communications radio.

Instructions de montage

Le chargeur peut être monté à l'horizontale ou à la verticale avec les câbles et les indicateurs DEL orientés vers le bas. Cinq (5) points de montage robustes sont moulés dans le boîtier en aluminium du chargeur et un autre trou de montage se trouve dans le centre de la poignée. Le chargeur peut être vissé sur une table ou un mur avec les quatre (4) fentes de montage, deux (2) de chaque côté, à l'aide d'attaches M6 ou de 1/4 de pouce. Un montage vertical à partir de la fente de montage en forme de trou de serrure à l'opposé des câbles est possible à l'aide d'un crochet en J approprié de 8 ou de 10 mm ou de 3/8 po. Un montage horizontal suspendu se réalise à l'aide d'une tige filetée de 5/16 po fixée au plafond avec des écrous au-dessus et en-dessous de la poignée.

Operating Instructions

CAUTION: The charger enclosure may be hot during charging. Use hand protection if handling the charger while charging.

- ✦ The extension cord must be a 3-wire cord less than 30m (100') at 10AWG or 7.5m (25') at 16AWG per UL guidelines.
- ✦ If you are connecting four (4) ELITE Chargers to a single 120V mains circuit, a 20A circuit is recommended.

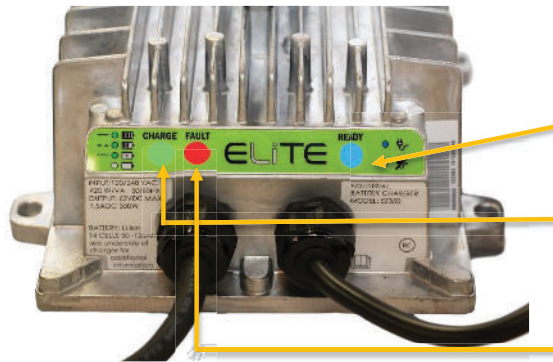

Charger Indicators

Indicator	Indication
<ul style="list-style-type: none"> ● AC Indicator Blue Light 	<ul style="list-style-type: none"> • If solid, AC power is present.
<ul style="list-style-type: none"> ● Charger Status Indicator Green Light 	<ul style="list-style-type: none"> • If solid, charging is complete. • If slow breathing, it is more than 80% charged. • If fast breathing, it is less than 80% charged.
<ul style="list-style-type: none"> ● Fault Indicator Red Light 	<ul style="list-style-type: none"> • Charger error. Refer to <i>Troubleshooting Instructions</i>.

Note: The charger will flash green when the lithium Battery Management System (BMS) is in wakeup mode.

DC Receptacle Indicators



LED	Indication
Solid	Charging is complete.
Slow Flash	More than 80% state of charge.
Fast Flash	Less than 80% state of charge.
Off	See charger indicators for status.

Mode d'emploi

MISE EN GARDE : Le boîtier du chargeur peut devenir chaud pendant le chargement. Utilisez une protection pour les mains si vous manipulez le chargeur pendant le chargement.

- + La rallonge électrique doit être un cordon à 3 fils de moins de 30 m (100 pi) de long à 10 AWG ou 7,5 m (25 pi) à 16 AWG selon les directives UL.
- + Si vous connectez **quatre (4) chargeurs ELITE** à un seul circuit de 120V, un circuit de 20 A est recommandé.

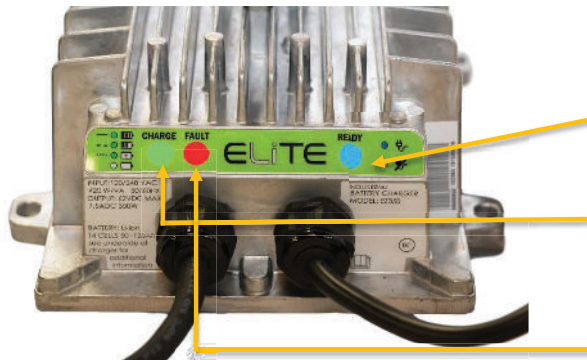

Indicateurs du chargeur

Indicateur	Indication
● Indicateur CA Voyant bleu	<ul style="list-style-type: none"> • Si constant, il y a une alimentation CA.
● Indicateur de l'état du chargeur Voyant bleu	<ul style="list-style-type: none"> • Si constant, la charge est terminée. • Si la pulsation est lente, la batterie est chargée à plus de 80%. • Si la pulsation est rapide, la batterie est chargée à moins de 80%.
● Indicateur de défaut Voyant rouge	<ul style="list-style-type: none"> • Erreur du chargeur. Consultez les <i>Instructions de dépannage</i>.

Remarque: le chargeur clignotera en vert lorsque le système de gestion de la batterie au lithium est en mode d'éveil.

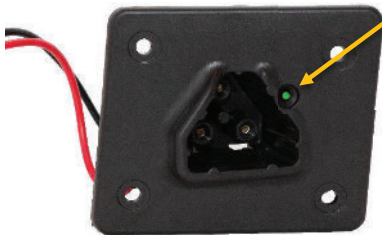





Indicateurs de prise de courant CC

DEL	Indication
Constant	La charge est terminée.
Clignotement lente	Charge de plus de 80%.
Clignotement rapide	Charge de moins de 80%.
Éteint	Voir les indicateurs du chargeur pour l'état.





Troubleshooting Instructions

If a fault occurs, count the number of red flashes between pauses and refer to this table:

Flashes	Cause	Solution
	The lithium battery pack issued a fault indicating a wiring or charger hardware issue.	Check the green DC paddle and receptacle for damage, corrosion, and ensure it is properly inserted. Reset the charger by interrupting AC power for 15+ seconds. If the fault returns, contact E-Z-GO Customer Care.
	The charge time or amp-hour limit was exceeded.	Check the green DC paddle and receptacle for damage, corrosion, and ensure it is properly inserted. Ensure the charger has sufficient cooling airflow in ambient temperatures below 40°C; if in the sun, move to the shade. Reset the charger by interrupting AC power for 15+ seconds. If the fault returns, contact E-Z-GO Customer Care.
	The lithium battery pack shut down charging and issued a fault.	Reset the lithium battery pack by turning the ignition and tow mode off, remove the green charger paddle from the receptacle, wait 5+ seconds, re-insert the paddle. If the fault returns, contact E-Z-GO Customer Care.
	Internal charger fault	Reset the charger by interrupting AC power for 15+ seconds. If the fault returns, contact E-Z-GO Customer Care.

Instructions de dépannage

S'il survient une erreur, comptez le nombre de clignotements rouges entre les pauses et reportez-vous au tableau suivant :

Clignotement	Cause	Solution
	Le bloc-batterie au lithium a émis un défaut indiquant un problème de câblage ou de matériel du chargeur.	Vérifiez la palette CC verte et la prise pour vous assurer qu'il n'y a pas de dommage ou de corrosion et assurez-vous qu'elle est bien insérée. Réinitialisez le chargeur en interrompant l'alimentation CA pendant 15 secondes ou plus. Si le défaut revient, communiquez avec le service à la clientèle E-Z-GO.
	La limite de temps de charge ou d'ampères par heure a été dépassée.	Vérifiez la palette CC verte et la prise pour vous assurer qu'il n'y a pas de dommage ou de corrosion et assurez-vous qu'elle est bien insérée. Assurez-vous que le chargeur a suffisamment de circulation d'air de refroidissement dans les températures ambiantes inférieures à 40° C. Si le chargeur est au soleil, mettez-le à l'ombre. Réinitialisez le chargeur en interrompant l'alimentation CA pendant 15 secondes ou plus. Si le défaut revient, communiquez avec le service à la clientèle E-Z-GO.
	Le bloc-batterie au lithium a arrêté la charge et a émis un défaut.	Réinitialisez le bloc-batterie au lithium en coupant l'allumage et en désactivant le mode de remorquage, enlevez la palette verte du chargeur de la prise, attendez 5 secondes ou plus et réinsérez la palette. Si le défaut revient, communiquez avec le service à la clientèle E-Z-GO.
	Défaut interne du chargeur	Réinitialisez le chargeur en interrompant l'alimentation CA pendant 15 secondes ou plus. Si le défaut revient, communiquez avec le service à la clientèle E-Z-GO.



Normal use, age, and wear on vehicle components can affect the safe operation and reliability of the vehicle. The recommended inspection and maintenance procedures are crucial for safety, performance, reliability, and maximum longevity of your vehicle.

A damaged vehicle, or a vehicle that is not functioning properly is dangerous and must not be operated until repairs are made.

NOTICE: Read the following operational warnings before driving the vehicle:

⚠ WARNING

Before exiting the vehicle, turn the key switch to the OFF position and remove the key from the vehicle to prevent unauthorized use.

Drive the vehicle at appropriate speeds for the terrain and conditions. Be aware of any environmental conditions that change the terrain and your ability to control the vehicle.

Do not drive on excessively steep hills. Evaluate the terrain before descending a hill. Drive slowly and deliberately. Use the brake to limit speed and maintain control. Sudden braking or turning can cause a loss of vehicle control. Drive straight down the hill. Do not drive across the hill.

Operate in approved areas.

Keep both feet, legs, hands, and arms inside vehicle at all times.

Avoid driving on terrain that is too rough for the vehicle's capabilities and your driving skills.

Before driving in the reverse direction, make sure the area behind the vehicle is clear. Accelerate slowly and avoid making sharp turns.

Make sure the direction selector is in the correct position before pressing the accelerator pedal.

Decrease speed before and during turns.

Bring the vehicle to a complete stop before moving the direction selector.

See *SPECIFICATIONS* on page 39 for the vehicle load and seat capacity.

NOTICE: Read the following maintenance information and warnings before servicing or repairing the vehicle:

Follow the procedures and comply with the safety information in this manual while performing vehicle service or maintenance.

Use the tools shown in the tool list and wear the specified safety equipment when performing vehicle service or maintenance.

⚠ WARNING

Remove all jewelry before servicing the vehicle.

Do not allow loose clothing or hair to contact the moving parts.

Do not touch hot objects.

The drive wheels must be lifted and supported on jack stands before performing any service to the powertrain while the motor is in operation.



When servicing the vehicle, always wear eye protection. Be careful when working around batteries, using solvents, or using compressed air.

Use insulated wrenches to decrease the risk of a short-circuit if a wrench contacts the battery terminals. A short-circuit in a battery can cause an explosion.

To prevent the risk of battery explosion, keep all flammable materials, open flames, or sparks away from the batteries.

Maintain constant awareness that some components are heavy, spring loaded, corrosive, explosive, can cause high amperage, or get extremely hot. Keep your hands, face, feet, and body away from any area that can expose them to injury if an unexpected situation occurs.



CUSHMAN®

TEXTRON SPECIALIZED VEHICLES, INC.

1451 Marvin Griffin Road
Augusta, Georgia 30906 - 3852
USA

CONTACT INFORMATION

North America:

Technical Assistance & Warranty:
Phone: 1-800-774-3946, FAX: 1-800-448-8124
Service Parts Phone:
1-888-GET-E-Z-GO (1-888-438-3946), FAX: 1-800-752-6175

International:

Phone: 001-706-798-4311, FAX: 001-706-771-4609

California Proposition 65

 **WARNING**

Operating, servicing and maintaining a passenger vehicle or off-road vehicle can expose you to chemicals including phthalates and lead, which are known to the State of California to cause cancer and birth defects or other reproductive harm. To minimize exposure, wear gloves and wash your hands frequently when servicing your vehicle.

For more information go to www.P65Warnings.ca.gov/passenger-vehicle

Parts Manuals and Service Manuals are available from a local Distributor, an authorized Branch, Genuine E-Z-GO Parts & Accessories Department or at www.shopezgo.com.

Copyrighted Material

This manual may not be reproduced in whole or in part without the express permission of the manufacturer.