



A Textron Company

**OWNER'S GUIDE**

***FLEET TXT ELITE***

**⚠ WARNING**

Read and comply with all of the instructions and safety precautions in this manual and on all product labels. Failure to follow the safety precautions could result in serious injury or death.

**⚠ WARNING**

**CALIFORNIA Proposition 65**

Motor vehicles may contain fuels, oils and fluids, battery posts, terminals, and related accessories which contain lead and lead compounds and other chemicals identified by the State of California to potentially cause cancer, birth defects, and other reproductive harm. These chemicals are found in vehicles, vehicle parts and accessories, both new and replacements. During maintenance, these vehicles generate used oil, waste fluids, grease, fumes, and particulates, all identified by the State of California to potentially cause cancer and birth defects or other reproductive harm.

Posted in accordance with Proposition 65 and California Health and Safety Code Section 25249.5, et seq.

**Lithium-Ion Batteries**

**⚠ CAUTION**

Improper storage may damage, destroy or cause permanent loss of battery capacity. Do not exceed storage time or temperature limits. Batteries must be charged to the correct level before storage. Storing fully depleted batteries will make them permanently unusable.

The storage time for properly charged Lithium-Ion batteries supplied with this vehicle varies based on the temperature.

Temperature	Length of Storage Time
-22°F to -4°F (-30°C to -20°C)	One month at 100% battery charge, all accessories turned off.
-4°F to 113°F (-20°C to 45°C)	Six months at 100% battery charge, all accessories turned off.
113°F to 140°F (45°C to 60°C)	One month at 30% - 50% charge, all accessories turned off.

**⚠ WARNING**

Never modify the vehicle in any way that will alter the weight distribution of the vehicle, decrease its stability or increase the speed beyond the factory specifications. Such modifications can cause serious personal injury or death. The manufacturer, **TEXTRON SPECIALIZED VEHICLES (TSV Augusta)**, prohibits and disclaims responsibility for any such modifications or any other alteration which would adversely affect the safety of the vehicle.

# OWNER'S GUIDE

## 48V TXT ELITE **FREEDOM**

*Starting MODEL YEAR 2017*

Beginning January 2017

These are the original instructions as defined by 2006/42/EC.

### CONTACT INFORMATION

Textron Specialized Vehicles, Inc.  
1451 Marvin Griffin Road  
Augusta, Georgia, USA 30906-3852

North America:

Technical Assistance and Warranty PHONE: 1-800-774-3946 FAX: 1-800-448-8124

Service Parts PHONE: 1-888-438-3946 FAX: 1-800-752-6175

International PHONE: 001-706-798-4311 FAX: 001-706-771-4609

[www.ezgo.com](http://www.ezgo.com)

## ***WELCOME***

Thank you for purchasing this vehicle. Before driving your new vehicle, read this owner's guide to familiarize yourself with safe driving practices, operation, features and controls.

This manual contains instructions for minor maintenance only. Information about major repairs can be found in the repair manual. Your dealer has thorough knowledge of your vehicle and wants your total satisfaction with your purchase. We recommend you return to your dealership for all of your service needs during, and after the warranty period.

Repair or replacement parts can be purchased from your dealer or through the manufacturer's parts and accessories department.

TSV maintains the right to change the design of the vehicle without responsibility to make the changes on units purchased before changes were made. The information in this manual can change without notice.

All information in this owner's Guide is based on the latest product information at the time of publication. Due to constant improvements in the design and quality of production components, some discrepancies may be found between your vehicle and the information presented in this publication. The content in this publication is intended for reference use only. The manufacturer is not liable for omissions or inaccuracies. Any reprinting or reuse of the content in this publication, whether whole or in part, is expressly prohibited.

Printed in USA

MANUFACTURER'S INTENDED USE .....	1
WARRANTY AND REGISTRATION .....	1
BATTERY PROLONGED STORAGE .....	1
Storage Preparation .....	1
Setting State of Charge (SOC) .....	2
During Storage .....	2
Extreme Low Temperature Storage .....	2
Returning Vehicle to Service .....	2
BATTERY DISPOSAL .....	2
VEHICLE SERIAL NUMBER LOCATION .....	3
REPAIR AND PARTS MANUALS .....	3
SAFETY .....	5
SAFETY LABELS .....	5
Operation (P/N 608529 or 614044 for CE) .....	5
Warning and Operation Label (P/N 628019 or 614043 for CE) .....	6
Tow Bar Label (P/N 625820 or 635906) .....	6
Run/Storage - Tow Label (P/N 613048) .....	6
Battery Warning (P/N 655748 or 659260 for CE) .....	6
MAXIMUM VEHICLE WEIGHT CAPACITY .....	7
TIRE PRESSURE .....	7
OPERATOR SAFETY .....	7
Unauthorized Operation .....	8
Operating without Instruction .....	8
Alcohol or Drugs .....	8
Before Operating .....	8
Operating With Passenger or Cargo .....	8
Driving in Reverse .....	8
Driving a Damaged Vehicle .....	8
Driving at Maximum Speeds .....	8
Driving on Different Surfaces .....	9
Driving on Public Roads .....	9
Turning .....	9
Driving Uphill .....	9

# TABLE OF CONTENTS

Driving Downhill .....	9
Stalling on a Hill .....	9
Tires .....	9
Slippery Terrain .....	9
BATTERY CHARGING .....	9
VEHICLE LIFTING .....	10
VEHICLE MODIFICATION.....	10
MAINTENANCE SAFETY .....	10
KEY SWITCH .....	11
HEADLIGHT SWITCH (IF EQUIPPED) .....	11
STATE OF CHARGE METER (IF EQUIPPED).....	11
HORN (IF EQUIPPED).....	11
DIRECTION SELECTOR .....	11
CUP HOLDER.....	11
12V OUTLET (IF EQUIPPED).....	11
USB PORT (IF EQUIPPED).....	11
STEERING WHEEL .....	11
TURN SIGNAL (IF EQUIPPED) .....	12
ACCELERATOR PEDAL.....	12
BRAKE PEDAL .....	12
PARKING BRAKE .....	12
SEAT .....	12
GLOVE BOX / STORAGE COMPARTMENTS .....	12
CANOPY TOP AND WINDSHIELD (IF EQUIPPED) .....	12
REAR SEAT AND CARGO PLATFORM (IF EQUIPPED) .....	12
SAFETY .....	13
BEFORE INITIAL USE .....	13
DAILY INSPECTION .....	13
ENVIRONMENTAL AWARENESS .....	13
BATTERY CHARGER.....	14
PERFORMANCE FEATURES .....	14
Speed Control .....	14
Pedal-Up Braking .....	14

High Pedal Disable Feature .....	14
Walk-Away Feature .....	14
Anti-Roll Back Feature .....	15
Anti-Stall Feature .....	15
Diagnostic Mode Feature .....	15
STARTING AND STOPPING THE VEHICLE .....	15
Starting on a Hill .....	15
ACCELERATING .....	16
BRAKING .....	16
Coasting .....	16
DRIVING PROCEDURE .....	16
Coasting .....	16
DRIVING WITH A PASSENGER .....	16
SLIPPERY SURFACES .....	17
DRIVING UPHILL .....	17
TRAVERSING HILLSIDES .....	17
DRIVING DOWNHILL .....	17
STALLING ON A HILL .....	18
DRIVING IN REVERSE .....	18
PARKING THE VEHICLE .....	18
Maximum Weight Capacity .....	18
MAINTENANCE SAFETY .....	19
SCHEDULED MAINTENANCE .....	19
SCHEDULED MAINTENANCE CHART .....	20
RECOMMENDED LUBRICANTS AND FLUIDS .....	21
REPLACEMENT OF MAINTENANCE ITEMS .....	21
LIFTING THE VEHICLE .....	22
Lifting Front .....	22
Lifting Rear .....	22
Lowering Vehicle .....	22
VEHICLE CLEANING AND CARE .....	23
Washing the Vehicle .....	23
Polishing the Vehicle .....	23

# TABLE OF CONTENTS

TIRES.....	23
Tire Pressure .....	24
Tire Repair .....	24
Tire Replacement .....	24
WHEELS .....	24
Wheel Removal .....	24
Wheel Installation .....	25
LIGHTS .....	25
Headlight Replacement .....	25
Turn Signal (if equipped) .....	25
Taillight .....	26
FUSE REPLACEMENT.....	26
SYSTEM TEST .....	26
REAR AXLE .....	26
Checking Lubricant Level .....	26
LUBRICATION .....	27
BRAKES.....	27
Periodic Brake Test .....	27
LITHIUM-ION BATTERY PACK.....	28
BATTERY CHARGING AND MAINTENANCE.....	28
BATTERY CHARGING .....	29
AC Voltage .....	29
BATTERY PROLONGED STORAGE .....	29
Storage Preparation .....	29
BATTERY FAULT DIAGNOSIS .....	29
TRANSPORTING THE VEHICLE .....	30
Towing the Vehicle .....	30
Hauling the Vehicle .....	30
VEHICLE SPECIFICATIONS.....	32
BATTERY CHARGER USER'S GUIDE .....	A1
DECLARATION OF CONFORMITY .....	B1



# INTRODUCTION

The following symbols appear throughout this manual and on vehicle labels. Your safety is involved when these symbols are used. Become familiar with their meanings before reading the manual.



**DANGER** indicates a hazardous situation that, if not avoided, will result in death or serious injury.



**WARNING** indicates a hazardous situation, if not avoided, could result in death or serious injury.



**CAUTION** indicates a hazardous situation that, if not avoided, could result in minor or moderate injury.



The **PROHIBITION SAFETY SIGN** indicates an action **NOT** to take in order to avoid hazard.



The **MANDATORY ACTION SIGN** indicates an action that **NEEDS** to be taken to avoid a hazard.



**WARNING** Failure to comply with the warnings in this manual can result in severe injury or death.



**WARNING** Read this entire manual carefully before operating this vehicle. Do not attempt to operate this vehicle until you have thorough knowledge of the controls and features.



**WARNING** Regular inspections and maintenance, along with good operating techniques, will help ensure your safe enjoyment of the capabilities and reliability of this vehicle.

This vehicle was designed and manufactured in the United States of America (USA). The standards and specifications in the following information originate in the USA unless otherwise indicated.

When servicing motors, all adjustments and replacement components must be per original vehicle specifications to maintain the USA Federal and State emission certification applicable at the time of manufacture.

## MANUFACTURER'S INTENDED USE

This vehicle is designed and manufactured for off road use only. Use on public streets, roads or highways is illegal in most areas and increases the risk of an accident involving other vehicles and people. This vehicle does not meet FMVSS (Federal Motor Vehicle Safety Standards) for public street, road or highway use.

Check all laws and regulations before choosing an area to operate your vehicle.

## WARRANTY AND REGISTRATION

Use Original Equipment Manufacturer (OEM) approved parts to keep the warranty effective.

All information, including coverage, limitations, exclusions and how to obtain warranty service is included in the literature package with the purchase of the vehicle. It can also be obtained from your E-Z-GO dealer.

A registration card is included in the literature package with the purchase of the vehicle.

## BATTERY PROLONGED STORAGE

**NOTICE: Improper storage may damage, destroy or cause permanent loss of battery capacity. Do not exceed storage time or temperature limits. Batteries must be charged to the correct level before storage. Storing fully depleted batteries will make them permanently unusable.**

### Storage Preparation

The optimum storage temperature range is between 65°F and 82°F (18°C and 28°C)

- Charge the battery module based on climate during storage period.
  - In cold climates, fully charge the battery module. Make sure that the charging operation is complete and there are no faults displayed on the charger. The green light on the charger should be on, indicating the charge cycle is complete.
  - In hot climates, store the vehicle with a 30% to 50% charge of battery pack capacity.
- Turn the key to the OFF position and remove it from the key switch.

## FEATURES AND CONTROLS

- Check the run - tow switch under the seat, make sure it is set in the RUN position.
- Turn off all accessories.

The storage time for properly charged Lithium-Ion batteries supplied with this vehicle varies based on the ambient temperature.

Temperature	Length of Storage Time
-22°F to -4°F (-30°C to -20°C)	One month at 100% battery charge, all accessories turned off.
-4°F to 113°F (-20°C to 45°C)	Six months at 100% battery charge, all accessories turned off.
113°F to 140°F (45°C to 60°C)	One month at 30% - 50% charge, all accessories turned off.

### Setting State of Charge (SOC)

The optional SOC meter or the hand held programmer may be used to determine the state of charge of the battery module. If the SOC is below 30%, charge the battery module until the state of charge reaches 50%. The charge cycle may be interrupted by disconnecting the charger from the AC power source first, then from the charging receptacle on the vehicle. If the SOC is above 50%, operate the vehicle until the SOC is below 50%.

### During Storage

Check the state of charge every 30 days. If the SOC is below 30%, charge the battery module until the state of charge reaches 50%.

### Extreme Low Temperature Storage

If the ambient temperature is below -4°F (-20°C) DO NOT:

- turn the vehicle key to the ON position
- drive the vehicle
- tow the vehicle
- charge the vehicle
- operate accessories
- turn the lights on (if equipped)

### Returning Vehicle to Service

At the end of the storage period, charge the battery module to 100% before operating the vehicle.

Before charging the vehicle be sure that the ambient temperature is between 14°F (-10°C) and 113°F (45°C) and the vehicle has had time to adjust to the temperature.

## BATTERY DISPOSAL



Lithium-Ion batteries are recyclable:

- Contact the distributor or manufacturer for information on returning or recycling used or damaged battery packs.
- Contact local or state environmental department for disposal information.
- Refer to the Maintenance section for additional information.

## VEHICLE SERIAL NUMBER LOCATION

Four serial number and manufacture date code labels are on the vehicle. One label is located on the steering column. The second label is located on the driver side frame under the front splash shield. The third and fourth labels are located on the passenger side frame rail at the rear of the vehicle. A PIN label is located on the passenger side frame under the front splash shield.

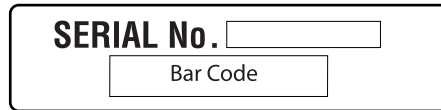
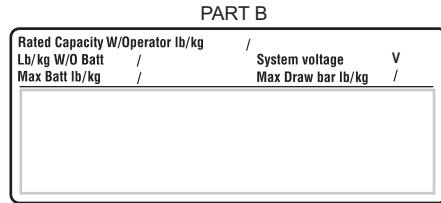
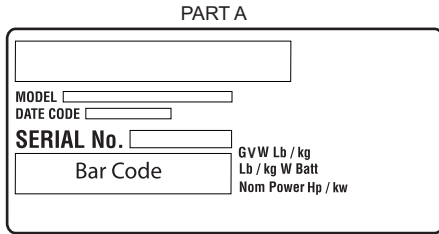

PART C and D

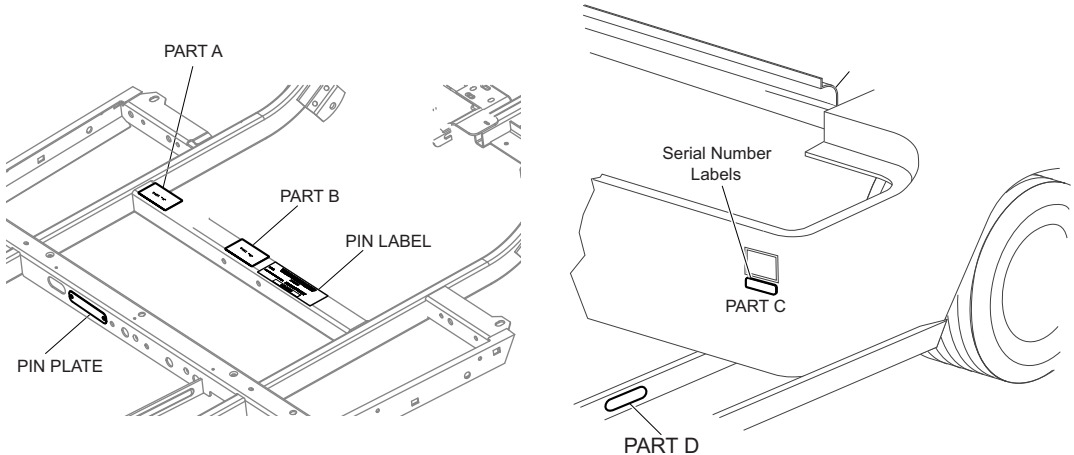

Design changes occur on a continuous basis. To order the correct components for the vehicle, the serial number or PIN and manufacture date are required.

Record the vehicle identification numbers in the spaces provided below. These identification numbers are required when ordering parts.

Vehicle Model Number: \_\_\_\_\_

Frame PIN: \_\_\_\_\_

## REPAIR AND PARTS MANUALS

The following manuals can be purchased through a dealer:

- repair manual
- parts manual



# SAFETY

## SAFETY

For questions about your vehicle or the material in this manual, see the contact information on page i or the back of this publication.

*Certain replacement parts can be used independently and/or in combination with other accessories to modify a TSV (Augusta) manufactured vehicle to permit the vehicle to operate at or in excess of 20 mph. When a TSV-manufactured vehicle is modified in any way by the Distributor, Dealer or customer to operate at or in excess of 20 mph on public streets or roads, UNDER FEDERAL LAW the modified product will be a Low Speed Vehicle (LSV) subject to the strictures and requirements of Federal Motor Vehicle Safety Standard 571.500. In these instances, pursuant to Federal law, the Distributor or Dealer MUST equip the product with headlights, rear lights, turn signals, seat belts, top, horn and all other modifications for LSV's mandated in FMVSS 571.500, and affix a Vehicle Identification Number to the product in accordance with the requirements of FMVSS 571.565. Pursuant to FMVSS 571.500, and in accordance with the State laws applicable in the places of sale and use of the product, the Distributor, Dealer or customer modifying the vehicle also will be the Final Vehicle Manufacturer for the LSV, and required to title or register the vehicle as mandated by State law.*

Information on FMVSS 571.500 is found at Title 49 of the Code of Federal Regulations, section 571.500. For information on-line, go to [www.ecfr.gov](http://www.ecfr.gov).

TSV will NOT approve Distributor, Dealer or customer changes that change a TSV product into a Low Speed Vehicle (LSV).

This vehicle meets the current applicable standard for safety and performance requirements.

## SAFETY LABELS

Safety and warning labels are on the vehicle for your protection. Read and comply with the instructions on the labels carefully. If any label shown in this manual is different from the label on your vehicle, always follow the instructions on the vehicle label.

If a label comes off or becomes illegible, contact your TSV dealer for a replacement. The part number is provided in this manual, printed on the label, or can be obtained from your dealer.

### Operation (P/N 608529 or 614044 for CE)

Located on the steering wheel.

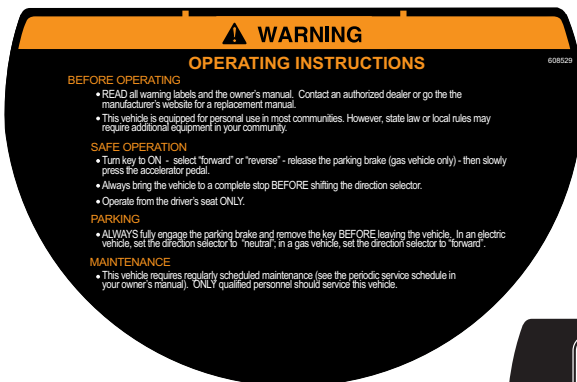

# SAFETY

## Warning and Operation Label (P/N 628019 or 614043 for CE)

Located on the cup holder.

**⚠ WARNING Failure to follow these instructions can result in SERIOUS INJURY or DEATH**

Except where PERMITTED BY LAW NEVER drive on public roads. Drivers must possess a valid drivers license in accordance with local state law.  
AVOID FALLS from this vehicle: Do not start moving until all occupants are PROPERLY SEATED and HOLDING ON. ● KEEP entire body INSIDE VEHICLE while moving.  
Reduce the RISK OF ACCIDENTS: Always DRIVE SLOWLY in congested areas, on wet or loose terrain, and when backing up. ● DRIVE SLOWLY when turning and AVOID sudden stops. ● ALWAYS drive straight up and down slopes. ● Do not coast, use BRAKE WHEN GOING DOWN A SLOPE. ● NEVER drive this vehicle under the influence of drugs or alcohol.  
This vehicle is NOT A TOY: Drive responsibly. ● NEVER leave children unattended or allow children to play on the vehicle. ● NEVER leave the key in the vehicle when parked.  
DO NOT OVERLOAD this vehicle: NEVER carry more than 2 occupants on each bench seat. ● Do not exceed vehicle WEIGHT CAPACITY (see Owner's Guide).  
DO NOT MODIFY this vehicle: NEVER alter this vehicle to increase travel speeds above factory specifications. ● ONLY authorized E-Z-GO dealers should alter the vehicle using approved parts. ● Alterations not approved or tested by E-Z-GO can create unsafe conditions and increase your chance of having an accident.

READ MANUAL BEFORE OPERATING

EZG19



## Tow Bar Label (P/N 625820 or 635906)

Located on the permanent tow bar.

This device is ONLY to be used for towing E-Z-GO vehicles. NEVER tow other vehicles or equipment. READ Owner's Manual before towing. FULLY ENGAGE coupling in bag well and safety pin at wheel spindle. NEVER tow more than 1 vehicle at one time. DRIVE SLOWLY and never tow over rough or unsafe terrain. NO RIDERS in towed vehicle. MONTHLY INSPECTION: tow bar pins, attaching hardware, and front frame attachment of towed cars. Replace worn or damaged parts. CHECK alignment of wheels on towed cars.

625820

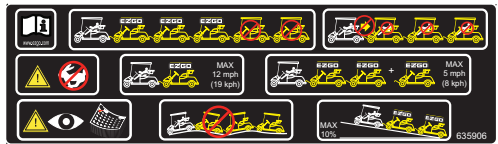

## Run/Storage - Tow Label (P/N 613048)

Located on the run/storage - tow cover on the passenger side below the seat.

**⚠ WARNING**

RUN
 TOW MAINTENANCE STORAGE

TOWING - Always select 'TOW MAINTENANCE' position before towing

- DO NOT alter or tamper with this unit. Unauthorized modifications can result in SERIOUS INJURY or damage to the vehicle and will void the warranty.
- To disable electrical system, turn key switch to 'OFF' and remove battery wires.

ALWAYS turn key to 'OFF' before disconnecting or reconnecting battery wires. ELECTRICAL ARC or BATTERY EXPLOSION can occur if key is not in the 'OFF' position.

- WAIT 30 seconds after reconnecting batteries BEFORE turning key switch to 'REVERSE', 'FORWARD' or 'NEUTRAL' positions.

613048

## Battery Warning (P/N 655748 or 659260 for CE)

Located on the battery pack cover.

**⚠ WARNING FAILURE TO FOLLOW THESE INSTRUCTIONS MAY RESULT IN SEVERE PERSONAL INJURY.**

No user serviceable parts.

- Service, removal or installation of battery pack must be performed by authorized personnel only.
- Charge with an OEM approved Lithium-Ion battery charger only.
- Do not store or operate at temperatures below -4°F (-20°C).
- Do not expose to temperatures above 140°F (60°C).

655748

659260

## MAXIMUM VEHICLE WEIGHT CAPACITY



**WARNING** Exceeding the weight capacities can cause loss of vehicle control and possible injury or death.

Maximum Vehicle Weight Capacity	800 lbs. (363 kg)
---------------------------------	-------------------

- Do not exceed the maximum vehicle weight capacity (includes weight of operator, passenger, cargo and accessories).

## TIRE PRESSURE



**WARNING** Improper tire pressure or uneven tire pressure can cause loss of vehicle control and possible injury or death.

Maintaining correct tire inflation pressure is essential for safe vehicle operation. You can vary the inflation pressure, within the recommended range to suit the condition of the terrain.

TIRE PRESSURE RANGE	TERRAIN CONDITIONS	RECOMMENDATION
18 - 22 psi (124 - 152 kPa)	hard surfaces or pavement	Inflate to higher pressure within the range; never exceed maximum pressure indicated.
	soft terrain or turf	Inflate to lower pressure within the range to reduce potential damage to the terrain or turf.

## OPERATOR SAFETY

Safe and responsible use of this vehicle is necessary to prevent dangerous conditions for the operator, passengers and other people in the area of operation. This section of the guide provides information on the safe operation of the vehicle. Make sure you read, understand and comply with all of this information to decrease the risk of personal injury or death.



**WARNING** Serious injury or death can occur if you do not follow the instructions and procedures shown in this owner's guide.

- Read this entire manual and all product labels carefully. Follow the safety information and operating procedures described.
- Operate your vehicle responsibly to prevent dangerous conditions for the operator, passengers and other people in the area of operation
- Operate your vehicle responsibly and keep the vehicle in safe condition of operation.
- A damaged vehicle, or a vehicle that is not functioning properly is dangerous and must not be operated until repairs are made.
- Keep feet, legs, hands and arms inside the vehicle at all times.
- The driver must keep both hands on the steering wheel and both feet on the floor or pedals.
- Inspect the vehicle before each use to make sure it is in safe operating condition. Perform the daily inspection described in this manual. See page 13.
- Always have the vehicle checked by an authorized dealer if it is involved in an accident.
- Remove the key when the vehicle is not in use to prevent accidental starting or unauthorized use.
- Drive the vehicle at appropriate speeds for the terrain and conditions. Be aware of environmental conditions that change the terrain and your ability to control the vehicle.
- Do not drive on excessively steep hills. Evaluate the terrain before descending a hill. Drive slowly and deliberately. Use the brake to limit speed and maintain control. Sudden braking or turning can cause loss of vehicle control. Drive straight up or down the hill; do not drive across the hill.
- Operate only in approved areas. Follow all applicable safety rules for the area.
- Avoid driving on terrain that is too rough for your vehicle's capabilities and your driving skills.
- Before you drive in the reverse direction, make sure the area behind the vehicle is clear. Accelerate slowly and avoid making sharp turns.
- Make sure the direction selector is in the correct position before you press the accelerator pedal.
- Decrease speed before and during turns.
- Decrease speed when driving on wet or slippery surfaces.

## SAFETY

- Bring the vehicle to a complete stop before you move the direction selector.
- Do not exceed the cargo or vehicle weight capacities. Do not exceed the occupant capacity. See *VEHICLE SPECIFICATIONS* on page 32 for the vehicle load and seat capacity.
- If there is a risk of lightning, leave the vehicle and look for a safe location to wait until the lightning has stopped.

Additional information about safety is included throughout this manual or can be obtained from your local TSV dealer.



**Failure to operate this vehicle as instructed can cause collision, loss of control or roll-over resulting in severe injury or death. Follow all safety warnings in this owner's guide. See the OPERATION section of the owner's guide for operating procedures and additional safety information.**

### Unauthorized Operation

Any person who does not have a valid driver's license is not permitted to operate the vehicle.

Any person who is below the height of 59 in. (150 cm) is not permitted to operate the vehicle.

Leaving the keys in the ignition allows unauthorized operation of the vehicle by an unlicensed driver or someone who does not meet the height requirement. Always remove the ignition key when the vehicle is not in operation.

### Operating without Instruction



Operation of this vehicle without proper instruction increases the risk of an accident. The operator must understand how to operate the vehicle correctly in different situations and on different types of terrain.

All operators must read, understand and comply with the all warning and instruction labels before operating the vehicle.

### Alcohol or Drugs



Operation of the vehicle during or after consuming alcohol or drugs can adversely affect operator judgment, reaction time, balance and perception.

Never drink alcohol or use drugs or medications before or during operation of the vehicle.

### Before Operating

Perform the *DAILY INSPECTION* on page 13 before each use to make sure the vehicle is in safe operating condition. Failure to inspect and confirm that the vehicle is safe to operate increases the risk of an accident.

Follow all inspection and maintenance procedures and schedules described in this owner's guide. See *SCHEDULED MAINTENANCE* on page 19.

### Operating With Passenger or Cargo

The weight of cargo and occupants affects vehicle operation. Carefully calculate how the vehicle is loaded and how to safely operate it.

Do not exceed weight capacities specified for your vehicle. Capacities are listed in *MAXIMUM VEHICLE WEIGHT CAPACITY* on page 7 of this manual, and also on the label affixed to the truck bed. As passenger weight increases, cargo weight needs to be adjusted to ensure the maximum vehicle weight capacity is not exceeded.

### Driving in Reverse

Make sure the area behind the vehicle is clear before operating in reverse. After making sure it is clear and safe to operate in reverse, accelerate slowly. Avoid making sharp turns in reverse. Refer to *Driving in Reverse* on page 18 for operational information.

### Driving a Damaged Vehicle

Driving a damaged vehicle is not safe.

If your vehicle has been involved in any type of accident, have it inspected by a qualified service dealer to verify that it is safe for operation.

### Driving at Maximum Speeds

Maximum speed operation increases risk of loss of control. Always drive at a speed that is appropriate for the terrain, visibility, operating conditions and your skill and experience level. Use the brake to control speed and maintain control of the vehicle.



**Driving on Different Surfaces**

Driving the vehicle on different surface types can affect handling characteristics of the vehicle. When driving on a dirt road, loose surface or wet grass, the distance required to stop the vehicles will increase.

**Driving on Public Roads**

Driving this vehicle on public streets, roads or highways could result in a collision with another vehicle. Never drive this vehicle on any public street, road or highway, including dirt and gravel roads, unless they are designated for off road use. Most areas prohibit the operation of this vehicle on public streets, roads or highways, and can result in traffic violations and fines.

**Turning**

Improper or careless turning can cause loss of traction, loss of control, accident or rollover. Do not turn quickly or at sharp angles. Do not turn at high speeds. Practice turning at slow speeds before attempting to turn at faster speeds.

**Driving Uphill**

Do not climb hills that are too steep for the vehicle or your driving abilities. Loss of vehicle control or rollover can result from climbing hills incorrectly. Refer to *Driving Uphill* on page 17 for operational information.

**Driving Downhill**

Inspect the terrain before descending a hill. Avoid driving across hills. Use the brake to limit speed and maintain control. Loss of vehicle control or rollover can result from driving downhill incorrectly. Refer to *Driving Downhill* on page 17 for operational information.

**Stalling on a Hill**

A rollover can result from stalling or rolling backward while climbing a hill. Drive uphill at a constant speed. See procedure on page 18 for maintaining control of your vehicle if it stalls on a hill.

**Tires**

Operating the vehicle with incorrect tires or with incorrect or uneven tire pressure can cause loss of control or an accident. Always use the size and type tires specified for the vehicle. See *VEHICLE SPECIFICATIONS* on page 32. Always maintain correct tire pressures as specified in *Tire Pressure* on page 7.

**Slippery Terrain**

Driving on rough, wet or loose terrain increases the risk of loss of traction or control, accident or rollover. Drive slowly and use correct turning procedures when operating on slippery surfaces.

Tires that have lost traction, and then regain traction suddenly, can cause loss of vehicle control or rollover. Refer to *Slippery Surfaces* on page 17 for operational information.

**BATTERY CHARGING**

Charging should be performed when ambient temperatures are between 40°F and 110°F (4°C and 42°C). The battery pack may be charged or topped off after every use.

The battery management system (BMS) and charger cooperate to make sure that charging occurs at the proper rate for the battery temperature. When the battery charger is connected to the vehicle, it will determine the charge rate based on the battery temperature. The charger will operate at the rates shown in the table below.

Charge Rate	Temperature
NO charging	below 14° F (-10°C) or above 140°F (60°C)
Pre-charge (charge at reduced rate, 6 amps)	between 14°F (-10°C) and 41°F (5°C) between 104°F (40°C) and 140°F (60°C)
Full charging	between 37.4°F (3°C) and 107.6°F (42° C)

The BMS will adjust the charge rate based on the temperature of the batteries.

Use only the OEM approved Lithium-Ion battery charger for your vehicle. See charger operating instructions in Appendix A.

- Turn the key to the OFF position and remove it.
- Inspect the charger cord for cracks, frayed wires or loose connections, if damaged replace it.

## SAFETY

- Inspect the vehicle charger receptacle and charger plug for dirt, debris or damage. Clean if necessary and replace immediately if damage is found.
- Connect the charger to a wall receptacle. Do not use a multi-plug adapter or power strip. Do not connect anything else to the same receptacle.
- Connect the charger to the vehicle receptacle.
- When the battery pack is finished charging, disconnect the charger cord from the vehicle. If disconnecting before the charge cycle is complete, it is recommended that the charger be disconnected from the wall receptacle first, then unplug the charger from the vehicle receptacle.

## VEHICLE LIFTING

The vehicle must be on a firm and level surface for lifting. Remain constantly aware that the vehicle is not stable during the lifting process. Do not get under a vehicle until you verify that it is stable on the jack stands. Never get under a vehicle while it is on a jack only. Put wheel chocks in front and behind the wheels that are not being lifted. Do not allow anyone to remain or get on the vehicle at any time during the lifting process.

Read and comply with all warnings and follow the lifting procedures described on page 22.

## VEHICLE MODIFICATION

Do not install any accessory not approved by TSV. Do not modify the vehicle to increase speed or power. Any modifications or installation of accessories not approved by TSV can create a safety hazard and increase the risk of injury.

The warranty will be terminated if the vehicle is modified to increase vehicle speed or power.

The warranty may be terminated if original (or equivalent) replacement parts are not installed on the vehicle.

The addition of some accessories can change the handling characteristics of the vehicle. Use only TSV approved accessories, and familiarize yourself with their function and effect on the vehicle.

## MAINTENANCE SAFETY

Routine and scheduled maintenance of this vehicle is necessary to keep your vehicle in safe and reliable condition. This section of the manual provides safety information for performing maintenance on your vehicle. Make sure you read, understand and comply with all of this information to decrease the risk of personal injury or death.

**⚠ WARNING** **Serious injury or death can occur if you do not follow the instructions and procedures shown in this owner's guide.**

- Read this entire manual and all product labels carefully. Follow the procedures and comply with the safety information in this manual while performing vehicle service or maintenance.
- Use the tools shown in the tool list and wear the specified safety equipment when performing vehicle service or maintenance.
- Remove all jewelry before you service the vehicle.
- Do not allow loose clothing or hair to contact the moving parts.
- Do not touch hot objects.
- The drive wheels must be lifted and supported on jack stands before you perform any service to the power-train while the motor is in operation.
- Use wheel chocks and support the vehicle on jack stands. NEVER get under a vehicle that is supported by a jack. Lift the vehicle following instructions. See *LIFTING THE VEHICLE* on page 22.



- When you service the vehicle, always wear eye protection.
  - Wear a face shield when working around the battery pack.
  - Be careful when working around batteries, using solvents or compressed air.
  - Use insulated tools within the battery area to prevent sparks or battery explosion.
  - To prevent the risk of battery explosion, keep all flammable materials, open flames or sparks away from the battery.
- Maintain constant awareness that some components are heavy, spring loaded, corrosive, explosive, can cause high amperage or get extremely hot.
  - After you make repairs or do maintenance, test the vehicle in a safe area that is free from vehicle and person traffic.

# FEATURES AND CONTROLS

**NOTICE:** 12V accessories must be connected to the DC to DC converter.

## KEY SWITCH

The key switch is a two-position switch; three-position if the vehicle is equipped with headlights.

- OFF - vehicle is disabled.
- ON - activates vehicle electronics and accessory power.

## HEADLIGHT SWITCH (IF EQUIPPED)

The headlight switch is a part of the key switch.

- Turn the key to light icon to switch the headlights on.

## STATE OF CHARGE METER (IF EQUIPPED)

The state of charge meter is on the dash panel beside the key switch. It indicates the amount of usable power in the batteries, with F indicating a full charge on the battery pack and E indicating low charge. The yellow light indicates the batteries must be charged immediately.

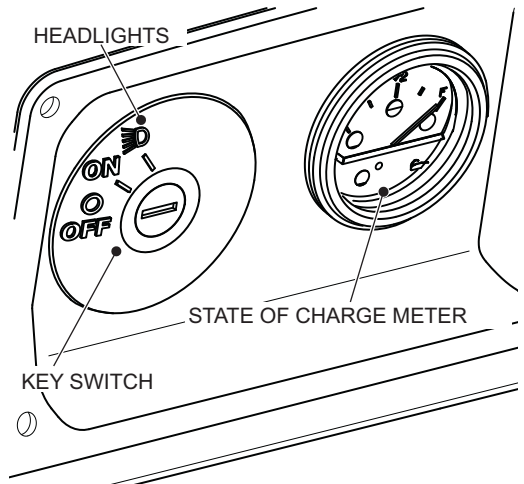

## HORN (IF EQUIPPED)

The horn button is located on the driver side of the floorboard. Press the button to activate the horn.

## DIRECTION SELECTOR

**WARNING** To prevent loss of control, do not move the direction selector while the vehicle is in motion. Moving the selector will result in sudden slowing of the vehicle and the beeping of a warning device.

The direction selector (F-N-R) is located on the seat wrap panel.

- R - allows the vehicle to be driven in reverse, also activates the reverse warning indicator.
- F - allows the vehicle to be driven in the forward direction.
- N - place the switch in the neutral position when parking the vehicle.



## CUP HOLDER

The vehicle has a center cup holder that will accommodate four beverage containers.

## 12V OUTLET (IF EQUIPPED)

**CAUTION** Excessive use of accessories that are connected to the outlet can drain the battery.

A 12V auxiliary outlet is located on the center console.

With the key switch in the ON position, the auxiliary outlet supplies power for any lights and accessories that have a 12V plug.

## USB PORT (IF EQUIPPED)

A USB port (if equipped) is located on the center console.

With the key switch in the ON position, the USB port supplies power to electronic devices via a USB cable.

## STEERING WHEEL

The steering wheel allows the driver to control the direction of travel.

## **FEATURES AND CONTROLS**

### **TURN SIGNAL (IF EQUIPPED)**

The turn signal switch is located on the steering column and is used to activate the turn signals.

### **ACCELERATOR PEDAL**

The accelerator pedal is the right pedal on the floorboard. It activates the engine and controls the acceleration of the vehicle.

Apply slow and steady pressure to the accelerator pedal to increase vehicle speed.

### **BRAKE PEDAL**

The brake pedal is located on the floor to the left of the accelerator pedal. The pedal is a combination brake and park brake; to activate the brake press the lower part of the pedal to slow or stop the vehicle.

### **PARKING BRAKE**

The foot operated parking brake is located along the top of the brake pedal. To engage the parking brake, push down on the upper section of the pedal until it locks in place. The parking brake will release when the lower part of the brake pedal is pressed.

### **SEAT**

The bench seat is designed for two occupants.

Lift up on either hip restraint to pivot the seat bottom forward and access the components underneath. Pivot and lift up on the seat to completely remove it from the vehicle.

### **GLOVE BOX / STORAGE COMPARTMENTS**

The glove box provides storage space for small items.

### **CANOPY TOP AND WINDSHIELD (IF EQUIPPED)**



#### **WARNING**

The canopy top does not provide protection from rollover or falling objects.

The windshield does not provide protection from tree branches or moving objects.

**NOTICE:** To prevent damage to the vehicle, do not hold on to the canopy top struts.

The canopy top and windshield provide some protection from the elements, but do not keep the operator and passenger dry in heavy rain.

The canopy top is not designed to provide rollover protection. In addition, the canopy top does not protect against falling objects, nor does the windshield protect against flying objects and tree limbs.

### **REAR SEAT AND CARGO PLATFORM (IF EQUIPPED)**



#### **WARNING**

Do not allow passengers to ride on the load deck. Severe injury or death could result if the vehicle is involved in an accident or if the vehicle makes a sudden change in direction.

The rear facing seat will accommodate two passengers, one on each side of the seat. Passengers must remain seated while the vehicle is in motion. Hand holds are provided, one on each side of the seat and one mounted to the footrest in the center.

Pivoting the seat bottom towards the rear of the vehicle will make the cargo platform available. When using the load deck always:

- Place the load as far forward as possible.
- Secure the load on the platform to prevent the load from moving.
- Make sure the center of gravity is less than 4 inches (10 cm) above the load deck.
- Do not exceed the load capacity of the load deck. The maximum capacity of the load deck is 250 lbs. (115 kg).

# OPERATION

## SAFETY



### WARNING

Failure to operate the vehicle correctly can result in a collision, loss of control, accident or rollover, and cause serious injury or death. Follow all operation procedures in this section of the manual. Read and comply with all safety warnings in the safety section of this owner's guide. This is a light-duty vehicle, NOT an All Terrain Vehicle (ATV).

## BEFORE INITIAL USE

To prepare your new vehicle for operation, complete the following:

- Remove the protective plastic from the seats.
- Check for possible leaks that may have developed during shipment of the vehicle.
- Establish acceptable stopping distance for brake performance test. See *Periodic Brake Test* on page 27.



### WARNING

Never charge a vehicle near flammable materials, open flame or sparks. Never charge a vehicle near gas water heaters and furnaces.

- Charge the batteries fully. See Battery Charging in the MAINTENANCE section of this manual.
- Perform the following daily inspection.

## DAILY INSPECTION

Inspect and verify that the vehicle is in safe operating condition before each use to decrease the risk of an accident. Check the items in the table to help ensure safe and reliable operation.

Item	Check
Batteries	Check charge level.
Brake system/pedal travel	Check for proper operation.
Parking brake	Ensure vehicle does not roll when the parking brake is engaged.
Front suspension	Inspect. Lubricate if necessary. Check for loose or missing hardware.
Rear suspension	Inspect. Lubricate if necessary. Check for loose or missing hardware.
Steering	Check for smooth and free operation.
Tires	Check condition and pressure.
Wheel hardware	Check for loose or missing hardware.
Frame hardware	Check for loose or missing hardware.
Fluid leakage	Inspect vehicle for leaks.
Switches	Check operation.
Reverse warning alarm	Check operation.
Headlights (if equipped)	Check operation.
Brake light / taillights (if equipped)	Check operation.

## ENVIRONMENTAL AWARENESS



### WARNING

When driving the vehicle, be careful of potential environmental hazards like steep slopes, rocks, tree branches, etc. that could cause an incident that could result in vehicle damage, personal injury or death.

- Always be respectful of the environment.
- Respect all wildlife and their habitat.
- Respect private property and comply with all local laws and regulations governing the use of golf and light duty utility vehicles.
- Make sure you are permitted by property owners to operate the vehicle on their property.

## OPERATION

### BATTERY CHARGER

The charger should be operated in accordance with the charger manufacturer's instructions. Always place the charger outside the vehicle before and during the charging cycle. Never charge batteries in a hazardous environment.

#### **DANGER**

**Risk of electric shock. Connect the charger power cord to an outlet that is correctly installed and connected to an electrical ground according to all codes and regulations. A grounded outlet is necessary to decrease the risk of electric shock – do not use ground adapters or replace the plug. Do not touch parts of output connector or battery terminals that do not have insulation.**

**Disconnect the AC plug before you make or break the connections to a battery that is charging. Do not open or disassemble the charger. Do not operate the charger if the AC cord is damaged. Make sure qualified personnel does all repair work to the charger.**

Refer to APPENDIX A for the charger manufacturer User's Guide for operating instructions, maintenance instructions and troubleshooting instructions.

The battery charger will test the temperature of the battery pack, if the temperature is too hot or too cold the charger will shutdown. If the battery pack temperature is within the safe to charge range the charger will operate.

### PERFORMANCE FEATURES

**NOTICE:** *The vehicle operates when the Run/Tow switch is in the RUN position.*

*The speed of the motor is sensed and controlled by the controller.*

#### Speed Control

#### **WARNING**

**The speed control system is not a alternative for the brake. Use the brake to control speed and decrease the risk of injury.**

Speed control system vehicles are equipped with a regenerative motor control system.

Example: If all of the following events occur:

- the vehicle is being driven down a slope
- the vehicle attempts to exceed the specified top speed with the accelerator pedal pressed **or** released

the regenerative brake will limit the speed of the vehicle to the specified top speed but the warning beeper will **not** activate. When the regenerative braking system is activated by this sequence of occurrences, the motor generates power which is returned to the batteries.

If the operator tries to override the electronic brake feature by moving the direction selector or key switch to another position, the warning beeper activates and the vehicle brakes **quickly** until it reaches approximately 2 mph (3 kph).

#### Pedal-Up Braking

Pedal-up braking is regenerative braking that occurs when the accelerator pedal is released while the vehicle is moving between 8 mph (13 kph) and the vehicle's top speed.

Example: If all of the following events occur:

- the vehicle is being driven down a slope
- the accelerator pedal is released for more than one second

Pedal-up braking decreases speed to 8 mph (13 kph), then the vehicle freely moves without the accelerator pressed, between 8 and 3 mph (5 kph), or the accelerator pedal is applied. The warning beeper will **not** activate. When pedal-up braking is activated by this sequence of occurrences, the motor generates power which is returned to the batteries.

#### High Pedal Disable Feature

High pedal disable prevents acceleration if the key is turned on while the accelerator or brake are pressed. To reset the controller after a High Pedal Disable, place both feet on the floor, turn the key to the OFF position. With both feet on the floor turn the key to the desired direction and press the accelerator.

#### Walk-Away Feature

Walk-Away limits vehicle movement without driver input, slowing the vehicle to 2 mph (3 kph) and sounding an audible alarm (reverse beeper).

Example: If all of the following events occur:

- the vehicle has been stopped for more than 1.5 seconds
- the accelerator pedal has been released for more than one second
- the vehicle begins to roll above 2 mph (3 kph)

The Walk-Away feature will limit speed to approximately 2 mph (3 kph) and the warning beeper will sound. When the accelerator pedal is depressed, the Walk-Away feature and warning beeper will be overridden and normal vehicle operation resumes. Any unusual situation sensed by the TruCourse Technology system will cause a similar response. The system functions in all key switch positions.

## Anti-Roll Back Feature

Anti-Roll Back, like Walk-Away, limits backward motion of the vehicle down an incline to less than 2 mph (3 kph). See 'Walk-Away Feature' above.

## Anti-Stall Feature

Anti-Stall protection prevents motor damage from stalling the vehicle against an object or on a hill.

Example: If all of the following events occur:

- the system senses that the accelerator pedal is depressed (power applied to motor)
- the motor is stalled long enough that any more time may cause motor damage

The Anti-Stall feature will momentarily interrupt power to the motor. This brief interruption will permit the car to roll backwards slightly before again stopping in the stalled condition. This process will repeat itself periodically until the car is moved from the stalled condition.

Example: If all of the following events occur:

- the system senses that the accelerator pedal is depressed (power applied to motor)
- the brake is engaged so as to prevent vehicle motion

the Anti-Stall feature will sense a stalled motor condition and remove power from the motor. When the brake pedal is released, the car will roll backwards slightly before power is returned to the motor.

## Diagnostic Mode Feature

Diagnostic mode helps with troubleshooting.

With some electrical system failures, the Diagnostic Mode feature defaults to a mode that allows the vehicle to operate at a decreased speed.

This feature allows you to return the vehicle to the storage facility and identify the problem.

The technician can put the controller in diagnostic mode and the controller identifies the failure mode.

## STARTING AND STOPPING THE VEHICLE

** WARNING** Unintentional roll-back of the vehicle could cause severe personal injury or vehicle damage. To reduce the possibility of vehicle roll-back, keep the brake fully pressed until the motor has started.

All vehicles have an *interlock system* that disables the controller and prevents operation or towing of the vehicle while the charger is connected. Remove the charger plug from the receptacle and correctly store the cable before you move the vehicle.

1. Sit in the driver's seat.
2. Insert the key and turn to the ON position.
3. Place the direction selector in F (forward) or R (reverse).

**NOTICE:** *When the direction selector is moved to the reverse position, a warning alarm will activate to indicate that the vehicle is ready to run in reverse.*

4. Release the parking brake by pressing the lower part of the brake pedal.
5. Slowly press the accelerator pedal to start the motor, release the brake pedal and accelerate slowly.
6. When the accelerator pedal is released, the motor decreases the speed of the vehicle. To stop the vehicle more quickly, press the brake pedal.
7. Turn the key to the OFF position and remove the key from the switch before exiting the vehicle.

### Starting on a Hill

** WARNING** To reduce the possibility of roll-back which could result in severe injury or vehicle damage, do not release the service brake until motor has started.

**NOTICE:** *Do not hold vehicle on hill by using accelerator and motor. Leaving motor in a stalled condition for more than 3 - 4 seconds will cause permanent damage to motor.*

## OPERATION

To reduce the possibility of permanent damage to the drive system, it is important to prevent excessive roll-back when starting the vehicle on a hill.

Place your left foot on brake pedal to release the park brake. Press accelerator with your right foot and release the brake pedal.

## ACCELERATING

**⚠ WARNING** Accidental movement of the accelerator pedal can cause the vehicle to suddenly move and cause severe injury or death.

Apply slow and steady pressure to the accelerator pedal to start the motor and accelerate the vehicle. When you release the accelerator pedal, the motor decreases the speed of the vehicle.

## BRAKING

**⚠ WARNING** When carrying cargo or towing a vehicle or trailer, the weight of the load will increase the braking distance required to slow or stop the vehicle. Not allowing for increased braking distance under load can cause an accident or injury.

1. Release the accelerator pedal completely.
2. Press the brake pedal to slow vehicle speed or stop the vehicle completely.
3. Practice slowing and stopping using the brake to become familiar with the controls.

## Coasting

The vehicle has a braking feature (pedal-up) that decreases the speed when the accelerator pedal is released. The feature continues to decrease the speed until the vehicle stops. Press the brake if you need to decrease speed or stop the vehicle quickly.

## DRIVING PROCEDURE

1. Perform the daily inspection. See page 13.
2. Sit in the driver's seat.
3. Check surroundings and determine the path of travel.
4. Insert the key and turn to the ON position.
5. Move the direction selector to the desired direction (F or R).
6. Release the parking brake by pressing the lower part of the brake pedal.
7. Slowly press the accelerator pedal to start the motor and release the brake pedal to accelerate.
8. Practice maneuvering the vehicle using the accelerator and brake pedals. Drive slowly and cautiously until you are comfortable with the controls.

## Coasting

**⚠ WARNING** Vehicle speed can increase quickly when driving downhill. Allowing the vehicle to coast downhill at high speeds can cause loss of control and result in severe injury or death. Limit your vehicle speed by pressing the brake.

Do not allow the vehicle to coast at speeds that are above the maximum recommended speed. Apply constant brake pressure when descending a hill to control the speed of the vehicle.

## DRIVING WITH A PASSENGER

- All passengers must be at least 59 in. (150 cm) tall. Passengers must be able to sit with their back against the seat and both feet on the floor.
- Do not allow more than one passenger in the vehicle.
- Do not allow a passenger to ride anywhere on the vehicle except the passenger seat.
- Travel at speeds appropriate for your skills, your passenger's skills and the operating conditions. Avoid unexpected or aggressive maneuvers that could cause discomfort or injury to the passenger.
- Handling characteristics can change with the added weight of a passenger. Allow more time and distance for braking.



## SLIPPERY SURFACES



### WARNING

Skidding or sliding can cause loss of control. Skidding or sliding can cause rollover if tires have lost traction, then regain traction suddenly. When operating on slippery surfaces, travel at reduced speed to help maintain control of the vehicle.

When operating in conditions such as ice, water, muddy trails, loose gravel or freezing temperatures, follow these guidelines:

- Do not operate on excessively rough, slippery or loose terrain.
- Slow down before entering potentially slippery areas.
- Maintain a high level of alertness, carefully evaluate the path of travel and avoid quick, sharp turns.
- Correct a skid by turning the steering wheel in the direction of the skid. *Never apply the brakes during a skid.*

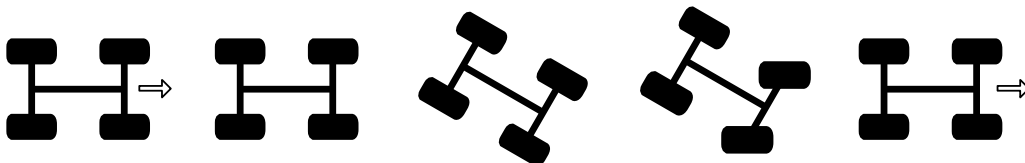

## DRIVING UPHILL

When driving up a hill, follow these guidelines:

- Drive straight up the hill.
- Avoid excessively steep hills.
- Keep both feet on the floor or pedals.
- Check the terrain before driving up a hill. Do not try to climb hills that have excessively slippery or loose surfaces.
- Drive at a steady rate of acceleration and speed.
- Do not drive over the crest of a hill at high speed. An obstacle, sharp drop, or another person or vehicle could be on the other side of the hill.
- Do not attempt to drive up a hill that is beyond your skill level.

## TRAVERSING HILLSIDES

Traversing a hillside is not recommended. Improper procedure can cause loss of control or a rollover. Avoid crossing the side of a hill unless absolutely necessary. If traversing a hillside is unavoidable, check the terrain and determine if it can be accomplished safely. Do not proceed if the terrain is beyond the vehicle or driver's ability.

If traversing a hillside is unavoidable, follow these guidelines:

- Drive slowly.
- Use extreme caution.
- Avoid crossing the side of a hill that has a slippery surface.
- Avoid crossing the side of a steep hill.
- When traversing a hillside that has soft terrain, it may be necessary to steer slightly uphill to keep the vehicle traveling in a straight line.
- If you feel that you are losing control of the vehicle, steer downhill if possible to regain control.

## DRIVING DOWNHILL



### WARNING

When carrying cargo or towing a vehicle or a trailer, the weight of the load will increase the braking distance required to slow or stop the vehicle. Not allowing for increased braking distance under load can cause an accident or injury.

When driving down a hill, follow these guidelines:

- Avoid excessively steep hills.
- Check the terrain carefully before descending any hill.
- Never drive down hills with excessively slippery or loose surfaces.
- Drive slowly.
- Drive straight down the hill. Avoid descending the hill at an angle that could cause the vehicle to lean sharply to one side.

## OPERATION

- Apply light and constant pressure to the brakes to maintain slow speed and control of the vehicle.

### STALLING ON A HILL

A rollover can result from stalling or rolling backward while climbing a hill. Drive uphill at a constant speed.

If your vehicle completely stalls while climbing a hill:

1. Apply the brakes.
2. Verify that the area behind you is clear.
3. Put the vehicle in R (reverse).
4. Use steady brake pressure to control speed, and allow the vehicle to slowly roll straight downhill.

If your vehicle begins to roll downhill:

1. Do not press the accelerator.
2. Apply the brakes gradually until the vehicle fully stops.
3. Verify that the area behind you is clear.
4. Put the vehicle in R (reverse).
5. Use steady brake pressure to control speed, and allow the vehicle to slowly roll straight downhill.

### DRIVING IN REVERSE

When driving in reverse, follow these guidelines:

- Check that the area behind the vehicle is clear of obstacles and people.
- Check left and right fields of vision before driving in reverse.
- Do not back down a steep hill.
- Drive in reverse slowly.
- Press the brakes lightly for stopping.
- Accelerate slow and steady.
- Avoid turning at sharp angles.

### PARKING THE VEHICLE

**NOTICE:** *When parking the vehicle inside a garage or structure, the space must be well ventilated. Park the vehicle away from any source of flame or sparks, including any appliance with a pilot light.*

***Park the vehicle on a flat surface if possible. If parking on an incline is unavoidable, be sure to chock the wheels to keep the vehicle from rolling.***

1. Press the brake to stop the vehicle.
2. Set the Parking Brake.
3. Turn the key switch to OFF.
4. Remove the key from the ignition to prevent unauthorized use.

### Maximum Weight Capacity

Maximum Vehicle Weight Capacity	800 lbs. (363 kg)
Maximum Towing Capacity	3 E-Z-GO ELiTE golf cars

- Do not exceed the maximum cargo load capacity.
- Do not exceed the maximum vehicle weight capacity (includes weight of operator, passenger, cargo and accessories).

# MAINTENANCE

## MAINTENANCE SAFETY



To prevent serious injury or death, follow the procedures and comply with the safety information in this manual while performing vehicle service or maintenance.

Do not remove the cover from the battery module(s). There are no serviceable items below the cover.

Use the tools shown in the tool list and wear the specified safety equipment when performing vehicle service or maintenance.

Remove all jewelry before you service the vehicle.

Do not allow loose clothing or hair to contact the moving parts.

Do not touch hot objects.

Before you disconnect or connect a battery or any other wires, ensure the key is in the OFF position.

Disconnect the negative battery terminal before you service the vehicle to prevent accidental operation.

The drive wheels must be lifted and supported on jack stands before you do any service to the power-train when the motor is in operation.

Support the vehicle with jack stands. NEVER get under a vehicle that is only supported by a jack. Lift the vehicle according to the manufacturers instructions.

Wear a face shield when working around the battery pack.

Be careful when working around batteries, using solvents or compressed air.

Use insulated tools within the battery area to prevent sparks or battery explosion.

To prevent the risk of battery explosion, keep all flammable materials, open flames or sparks away from the battery.

Maintain constant awareness that some components are heavy, spring loaded, corrosive, explosive, can cause high amperage or get extremely hot.

After you make repairs or do maintenance, test the vehicle in a safe area that is free from vehicle and pedestrian traffic.

**NOTICE:** To decrease the risk of damage to the controller or motor, move the run/tow switch to the TOW position before you tow the vehicle.

*An E-Z-GO ELiTE golf car can not be used to tow E-Z-GO vehicles with lead acid batteries. The ELiTE golf car can tow up to three ELiTE model golf cars properly equipped with an approved tow bar system.*

*Never tow an E-Z-GO vehicle with any vehicle except an E-Z-GO golf car with an approved tow bar system.*

*After you connect a battery or any other wires, wait a minimum of 30 seconds before you move the switch to the RUN position.*

## SCHEDULED MAINTENANCE

Consistent inspection, adjustment and lubrication of some components are necessary to maintain your *vehicle* so that it remains in safe and reliable condition. Refer to the *SCHEDULED MAINTENANCE CHART* on page 20 for detailed requirements.

Inspect, clean, lubricate, adjust and replace parts as necessary. Use OEM or equivalent replacement parts.

Record the maintenance items performed along, with details in the *MAINTENANCE LOG* beginning on page 35.

# MAINTENANCE

**NOTICE: Service and adjustments are important for safe and reliable vehicle operation. If not familiar with safe service and adjustment procedures, have your dealer perform the operations.**

## SCHEDULED MAINTENANCE CHART

Perform all services at the maintenance interval reached first.

**S** – Indicates operations that need to be performed more frequently on vehicles subjected to severe use.

Item	Interval (perform at interval that comes first)		Remarks	Page
	Rounds	Calendar		
Overall vehicle condition	Daily		Inspect.	
Battery Module	Daily		Charge daily after use.	
Steering	Daily		Check for smooth and free operation.	
Front suspension	Daily		Inspect. Check for leaks and loose or missing hardware.	
Rear suspension	Daily		Inspect. Check for leaks and loose or missing hardware.	
Tires	Daily		Check condition and pressure.	7
Wheel lug nuts	Daily		Check for loose or missing.	24
Accelerator	Daily		Check for smooth operation.	
Brake system	Daily		Check for smooth operation and acceptable stopping distance.	
Headlights and taillights (if equipped)	Daily		Check operation. Replace bulbs as needed.	25
Reverse warning alarm	Daily		Check operation.	
Switches	Daily		Check operation.	
Fluid leakages	Daily		Inspect entire vehicle for leaks	
Charger receptacle	Daily		Clean connections.	
Accelerator	Daily		Check for smooth operation.	
<b>S</b> Brake pads or shoes	20	Monthly	Inspect. Replace as needed.	
Wiring	20	Monthly	Inspect for loose connections, broken or missing insulation.	
Steering	20	Monthly	Check for excess play, loose or missing hardware.	
<b>S</b> Tie rods	20	Monthly	Check for excess play, bent rods, loose or missing hardware.	
Front suspension	20	Monthly	Inspect strut for leaks. Check hubs and kingpins, for excessive play, worn bushings, loose or missing hardware.	
Rear axle	20	Monthly	Check for leakage; add oil as required.	
Front wheel alignment	60	3 Months	Check for unusual tire wear and adjust if necessary	
Rear Suspension	60	3 Months	Check for shock oil leakage, worn bushings, loose or missing hardware.	
Rear axle	500	5 years	Replace fluid.	

**RECOMMENDED LUBRICANTS AND FLUIDS**

Check and lubricate all components at the intervals shown in the *SCHEDULED MAINTENANCE CHART* beginning on page 20.

<b>Item</b>	<b>Capacity</b>	<b>Lubricants/Fluids</b>
Rear axle oil	12 oz. (1.2 liters)	30 Weight Engine Oil

**REPLACEMENT OF MAINTENANCE ITEMS**

These items or their equivalents can be purchased through your dealer, directly from TSV or any other qualified source.

<b>Item</b>	<b>Part Number</b>
15 Amp Fuse	18392G1
Headlight Bulb 894	74004G01
Turn Signal Bulb	604539
Taillight Bulb 1157	21759G1

# MAINTENANCE

## LIFTING THE VEHICLE

### ⚠ WARNING

Read and comply with all of the following warnings and lifting procedures to prevent the possibility of the vehicle falling and causing serious injury or death.

For some maintenance procedures, it is necessary to lift the vehicle. Comply with the following warnings and follow the lifting procedure to ensure the safety of you, your vehicle and surroundings.

### ⚠ WARNING

The vehicle must be on a firm and level surface for lifting.

Remain constantly aware that the vehicle is not stable during the lifting process.

Place the jack and jack stands only in the areas indicated in the following illustration.

Do not get under a vehicle until it's stability on the jack stands is verified; never get under a vehicle while it is on a jack only.

Put wheel chocks in front and behind all wheels that are not being lifted.

Do not allow anyone to remain or get on the vehicle at any time during the lifting process or when the vehicle is lifted.

When performing any service to the drive-train, lift drive wheels off the ground.

### Tools

- jack
- jack stands (4)
- wheel chocks

### Lifting Front

1. Chock the rear wheels to keep the vehicle from rolling backward.
2. Place the jack at the center of the front axle.
3. Raise the vehicle enough to place jack stands under the frame cross-member as indicated.
4. Lower the vehicle until it rests on the jack stands.
5. Remove the jack.
6. Confirm that the vehicle is stable on the jack stands before proceeding with any service.

### Lifting Rear

1. Chock the front wheels to keep the vehicle from rolling forward.
2. Put a jack under the center of the rear frame member.
3. Raise the vehicle with the jack.
4. Place a jack stand under each side of the rear axle.
5. Lower the vehicle until it rests on the jack stands.
6. Remove the jack.
7. Confirm that the vehicle is stable on the jack stands before proceeding with any service.

### Lowering Vehicle

1. Make sure chocks are still in place on any wheels that remain on the ground.
2. Put the jack in the same location that was used to raise the vehicle.
3. Raise the vehicle enough to remove the jack stands. Remove the jack stands from underneath the vehicle.
4. Slowly lower the vehicle to the ground and remove the jack.

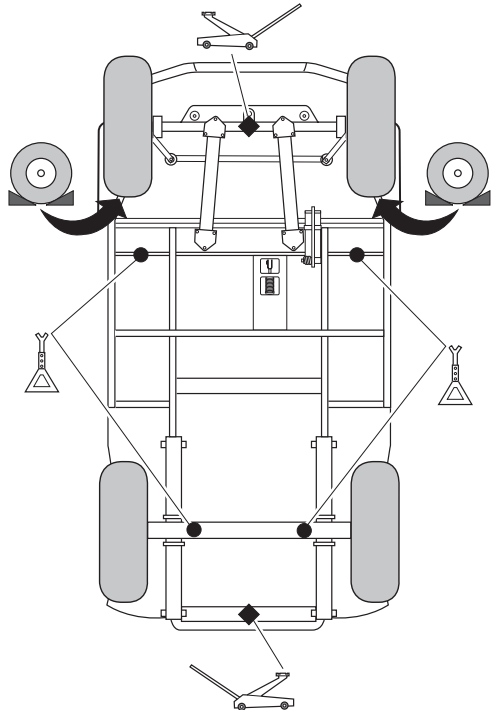

## VEHICLE CLEANING AND CARE

Keeping your vehicle clean is not only beneficial to its appearance, but can also help extend the life of various components.

### Washing the Vehicle

**NOTICE: Do not use more than 700 psi pressure to wash your vehicle. High water pressure can damage components.**

***Some products, including insect repellents and chemicals, will damage plastic surfaces. Do not allow these types of products to contact the vehicle.***

- Do not use more than 700 psi pressure to clean the vehicle.
- Use an automotive type cleaner or mild soap to wash the vehicle. Harsh cleaners can scratch the finish.
- Use clean or new cloths and pads for washing. Reused cloths and pads can contain dirt particles that will scratch the finish.
- Inspect all grease fittings for dirt intrusion or lack of grease after washing. Apply grease as required to maintain proper function.
- Use a sponge or soft brush and a soap/water solution to clean the vinyl seats. Rinse with clean water.
- Use an automotive type wash cloth to wash the body of the vehicle. To prevent the soap from drying on the vehicle, rinse with clean water frequently.
- Clean the windshield with water and a clean cloth. Remove small scratches with a plastic polish.
- Clean the bottom of the vehicle where mud or dirt can collect. Loosen any packed sediment to help with removal. Be careful not to damage the paint.
- Dry the vehicle with a chamois before the water dries to prevent water spots.

### Polishing the Vehicle

- Do not use medium to heavy duty compounds on the finish. Use wax that is for clear coat automotive finishes only. Do not apply wax or polish to matte finish surfaces.
- Use clean or new cloths and pads for polishing. Old or reused cloths and pads can contain dirt particles that will scratch the finish.

## TIRES

Follow the tire maintenance procedures as instructed in this manual and on the labels on the vehicle.

Always use approved size and type of replacement tires. See *VEHICLE SPECIFICATIONS* on page 32.

** WARNING** Worn, improperly inflated, improper sized, or incorrectly installed tires will affect vehicle handling and could cause an accident resulting in severe injury or death.

**Inflate all tires to the same pressure. Operating with unequal or incorrect pressure can adversely affect steering and handling and could cause an accident resulting in severe injury or death.**

**To decrease the risk of tire explosion, do not exceed the tire inflation rating on the tire sidewall. Make sure the tires are properly inflated at all times of operation.**

**To decrease the risk of tire explosion, inflate small amounts of air into the tire at intervals to allow the beads to seat properly. Because of the low volume of the small tires, over inflation can occur in seconds. Never exceed the tire inflation pressure rating on the tire sidewall when seating a bead. Protect your face and eyes when you remove a valve core.**

**When you remove the wheels, use only sockets made for impact wrenches to decrease the risk of injury by a broken socket.**

**Do not use tires with low rated pressure. Do not use tires that have a recommended tire inflation pressure less than the tire inflation pressure recommended in the owner's guide.**

**Do not over inflate the tires. Excess pressure can cause the tire to separate from the wheel or cause a tire explosion.**

# MAINTENANCE

## Tire Pressure

Maintaining correct tire inflation pressure is essential for safe vehicle operation. You can vary the inflation pressure, within the recommended range to suit the condition of the terrain.

TIRE PRESSURE RANGE	TERRAIN CONDITIONS	RECOMMENDATION
18 - 22 psi (124 - 152 kPa)	hard surfaces or pavement	Inflate to higher pressure within the range; never exceed maximum pressure indicated.
	soft terrain or turf	Inflate to lower pressure within the range to reduce potential damage to the terrain or turf.

## Tire Repair

**NOTICE: Tire repairs are not covered under the vehicle warranty.**

### Tools

- lug wrench, 3/4"
- impact socket, 3/4"
- impact wrench
- torque wrench, ft.lbs.

**NOTICE: Tire plug tools and plugs are available at automotive outlets. The tire does not have to be removed from the wheel to install the tire plug.**

Use a tire plug to repair small holes in the tread part of the tire. For large holes or holes/cuts in the tire sidewall, the tire must be replaced.

1. Remove the wheel from the vehicle. See *Wheel Removal* on page 24.
2. Locate the leak in the tire.
  - a. If the tire is very low or flat, fully inflate the tire.
  - b. Brush soapy water over the surface of the tire. Air bubbles will be visible where the air is leaking from the tire.
  - c. Mark the hole with chalk.
3. Install the plug according to the manufacturer's instructions.
4. Install the wheel on the vehicle. See *Wheel Installation* on page 25.
5. Fully inflate the tire. See *Tire Pressure* on page 7.

## Tire Replacement

Tire replacement requires a tire mounting machine and must be done by a qualified tire center or you TSVr dealer.

## WHEELS



### WARNING

**Worn, improperly inflated, improper sized, or incorrectly installed tires will affect vehicle handling and could cause an accident resulting in severe injury or death.**

**NOTICE: To decrease the risk of component damage, do not tighten the lug nuts to more than the torque specified below.**

Check lug nuts for tightness at the intervals indicated in the *SCHEDULED MAINTENANCE CHART* on page 20.

## Wheel Removal

### Tools

- lug wrench, 3/4"
- impact socket, 3/4"
- impact wrench
- torque wrench, ft.lbs.

1. Lift the vehicle. See *LIFTING THE VEHICLE* on page 22.
2. Remove the lug nuts.
3. Remove the tire from the vehicle.

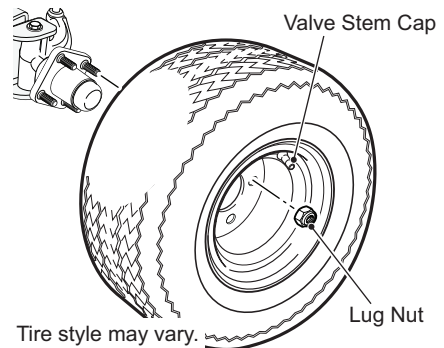



## Wheel Installation

Lug Nut Torque	50 - 85 ft.lbs. (68 - 115 Nm)
----------------	-------------------------------

**NOTICE:** To decrease the risk of component damage, do not tighten the lug nuts to more than the specified torque.

**Always install lug nuts using a cross sequence pattern to ensure even seating of the wheel against the hub.**

1. Install the wheel on the hub with lug nuts. Make sure the valve stem is to the outside.
2. Finger tighten the lug nuts.
3. Using the tightening pattern shown at right, tighten the lug nuts to 50 - 85 ft.lbs. (68 - 115 Nm). Tighten in increments of 20 ft. lbs. (27 Nm).

Lug Nut Tightening Pattern

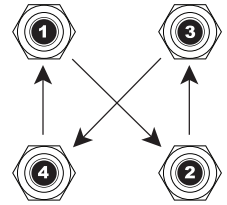

## LIGHTS

- Clean the lights frequently to maximize visibility.
- Replace burned out bulbs promptly.

### CAUTION

Do not operate this vehicle at night or in low light if any bulbs are burned out. Poor lighting reduces visibility that could cause an accident resulting in severe injury or death.

**NOTICE:** Replacement bulbs are available from a local Distributor, an authorized Branch or the Service Parts Department.

## Headlight Replacement

### CAUTION

Light components can get hot if they have been in operation. Allow the lights to cool before servicing to prevent burns to the skin.

**NOTICE:** Do not touch a halogen bulb with bare fingers. Oil from skin leaves a residue that causes a hot spot and will diminish the life of the bulb.

Make sure the vehicle key switch is in the OFF position and the key has been removed from the switch.

1. Pull the locking ring straight off the back of the light housing and allow it to slide down the harness and out of the way.
2. Rotate the bulb socket counter-clockwise and pull to remove the bulb and socket.
3. Pull the bulb out of the socket.
4. Insert the new bulb into the socket
5. Install the new bulb and socket into the headlight opening and rotate the socket a quarter turn clockwise to secure it in the housing.
6. Slide the locking ring over the socket and onto the back of the housing.

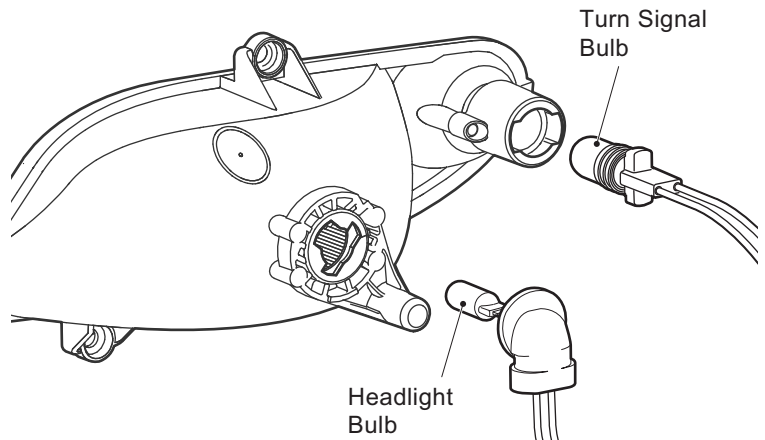

## Turn Signal (if equipped)

Make sure the vehicle key switch is in the OFF position and the key has been removed from the switch.

1. Rotate the bulb socket a quarter turn counter-clockwise to unlock it. Pull the socket and bulb out of the housing.
2. Remove the turn signal bulb from the housing socket and install a new bulb.
3. Align the turn signal housing with the opening in the back of the light assembly, turn the housing a quarter turn clockwise to secure it.

## MAINTENANCE

### Taillight

Make sure the vehicle key switch is in the OFF position and the key has been removed from the switch.

1. Remove two Phillips head screws that secure the lens to the taillight assembly.
2. Remove the light bulb.
3. Install the new light bulb.
4. Install the lens and secure the lens with two Phillips head screws.

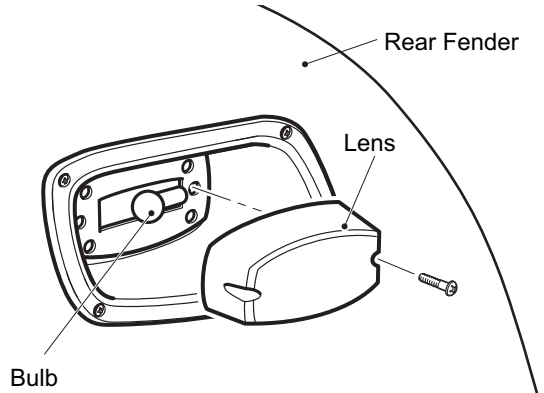

### FUSE REPLACEMENT

The fuse block is located on the fender liner on the driver side of the vehicle. To replace a fuse, raise the seat bottom and locate the blown fuse. Remove the old fuse and replace with a new fuse of the same type and size.

### SYSTEM TEST

At monthly intervals, test the controller by allowing the vehicle to roll down an incline with the accelerator pedal released. Braking force should be felt at approximately 2 mph (3 kph) indicating that the system is functioning. If vehicle speed continues to rise, apply the service brake and have vehicle inspected by a trained mechanic.

### REAR AXLE

The only maintenance necessary for the first five years is the inspection of the rear axle for lubricant leakage. Unless leakage is visible, the lubricant needs to be replaced after five years. Refer to the Repair Manual for the fluid replacement procedure.

Change the axle oil at the intervals indicated in the *SCHEDULED MAINTENANCE CHART* on page 20. The drain plug is located at the bottom of the rear axle housing.

### Checking Lubricant Level

Clean the area around the check/fill plug and remove plug. The correct lubricant level is just below the bottom of the threaded hole. If lubricant is low, add lubricant as required. Add lubricant slowly until lubricant starts to seep from the hole. Install the check/fill plug. In the event that the lubricant is to be replaced, the oil pan must be removed or the oil siphoned through the check/fill hole.

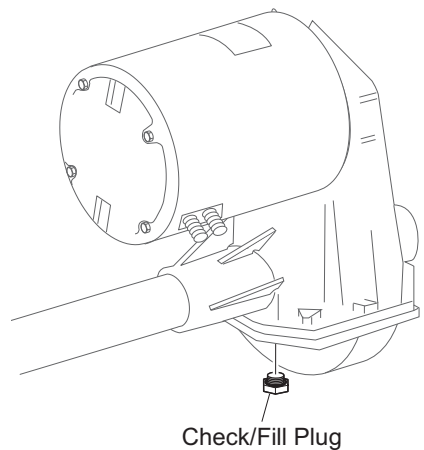
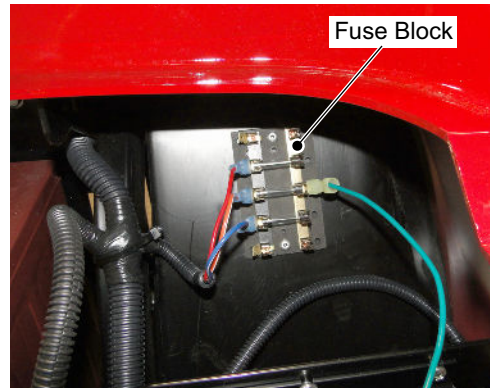

**LUBRICATION**

**NOTICE:** Do not use more than three (3) pumps of grease in any grease fitting at any one time. Excess grease may cause grease seals to fail or grease migration into areas that could damage components.

Putting more than three pumps of grease in a grease fitting could damage grease seals and cause premature bearing failure.

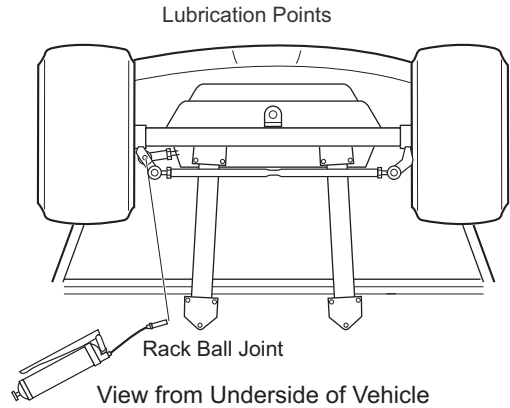

**BRAKES**



**WARNING** To reduce the possibility of severe injury or death, always evaluate pedal travel before operating a vehicle to verify some braking function is present.

All driving brake tests must be done in a safe location with regard for the safety of all personnel.

**NOTICE:** Over time, a subtle loss of performance may take place; therefore, it is important to establish the standard with a new vehicle.

The Periodic Brake Performance Test should be performed regularly as an evaluation of braking system performance. It is useful as a method of identifying subtle loss of performance over time.

**Periodic Brake Test**

The purpose of this test is to compare the braking performance of the vehicle to the braking performance of new or 'known to be good' vehicles or to an established acceptable stopping distance. Actual stopping distances will be influenced by weather conditions, terrain, road surface condition, actual vehicle weight (accessories installed) and vehicle speed. No specific braking distance can be reliably specified. The test is conducted by latching the park brake to eliminate different pedal pressures and to include the affects of linkage mis-adjustment.

Establish the acceptable stopping distance by testing a new or 'known to be good' vehicle and recording the stopping location or stopping distance. For fleet vehicles, several vehicles should be tested when new and the range of stopping locations or distances recorded.

Drive the vehicle at maximum speed on a flat, dry, clean, paved surface. Quickly press the brake pedal to latch the parking brake at the line or marker in the test area and remove foot from pedal. The vehicle should stop aggressively. The wheel brakes may or may not lock. Observe the vehicle stopping location or measure the vehicle stopping distance from the point at which the brakes were latched. The vehicle should stop within the 'normal' range of stopping distances. If the vehicle stops more than 4 ft. (1.2 m) beyond the acceptable stopping distance or pulls to one side, the vehicle has failed the test and should be tested again.

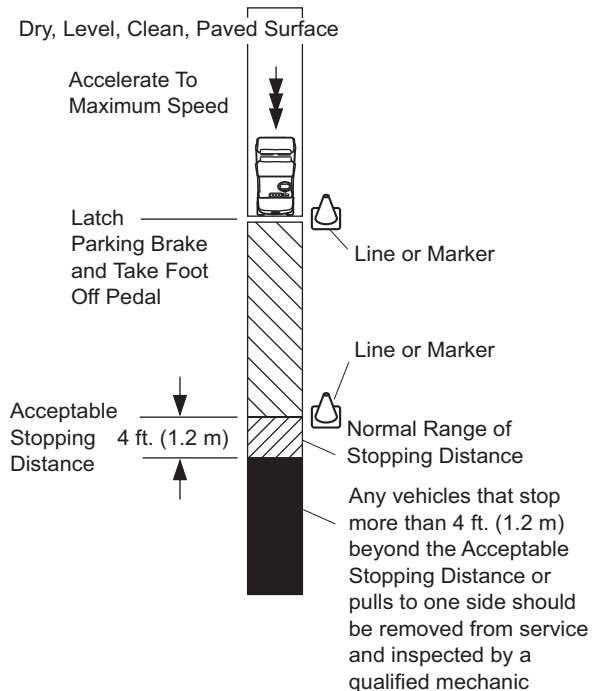

If the vehicle fails the second test, it should **immediately** be removed from service. The vehicle **must** be inspected by a qualified mechanic who should refer to the TROUBLESHOOTING section in the Repair Manual.

## MAINTENANCE

### LITHIUM-ION BATTERY PACK

Charge the battery pack using only the OEM approved Lithium-Ion battery charger.

#### WARNING

Improper handling of batteries and electrical components can result in serious injury or death.

Do not remove the battery pack cover. Do not attempt to remove batteries or battery cables. Do not use the battery pack without the control module installed. All battery and electrical service must be performed by an authorized service facility.

All tools used in or around the battery pack area should be insulated. Do not intentionally cause a short to the power terminal (P+, P-, B+, B-) with a metallic object.

Do not use the vehicle or charge the battery pack if the battery pack has become abnormally hot, is discolored, deformed, leaking or has an odd odor. If liquid from the battery pack leaks onto skin or clothes, wash well immediately with fresh, running water. If liquid gets into the eyes, do not rub the eyes. Wash the eyes with fresh, running water and seek medical assistance immediately.

Do not cut, tear or remove the seal tape. Do not disassemble or modify the design, including the electrical circuit, of the battery pack or control module.

To prevent the risk of battery explosion, keep all flammable materials, open flames or sparks away from the batteries. Do not leave the battery pack near a fire or heat source. Do not throw Lithium-Ion batteries into a fire. Do not apply heat to any part of the battery pack or battery management module with a soldering iron. Do not place the battery pack in a microwave oven, dryer or high-pressure container.

Make sure that the key switch is in the OFF position and the run/tow switch is in the RUN position before you start to work on the vehicle.

Do not attempt to operate the vehicle or charge the battery pack at temperatures above 140°F (60°C).

Do not immerse or throw the battery pack in water. Do not pressure wash the battery pack.

Do not puncture the battery pack or control module. Do not strike the battery pack with a hammer or heavy weight. Do not step or stand on the battery pack. Do not throw or drop the battery pack on hard surfaces.

If the battery pack terminals are contaminated or dirty, clean them with a dry cloth before using the battery pack.

Keep the battery pack and control module away from static electricity.

#### WARNING

Before recycling or shipping battery pack, make sure that the battery pack terminals are insulated.



Lithium-Ion batteries are recyclable:

- Return discarded batteries to distributor or manufacturer for recycling.
- Contact local or state environmental department for the disposal information.
- Refer to the Maintenance section for additional information.

### BATTERY CHARGING AND MAINTENANCE

#### WARNING

Do not attempt to start the vehicle or charge the battery pack if the vehicle has been stored at or below freezing temperatures.

**NOTICE:** Do not spray the battery module with water. Do not attempt to add water to the battery module.

Do not charge the batteries if the ambient temperature is below -4°F (-20°C) or above 113°F (45°C). Refer to Appendix A for battery charger operating instructions.

Before connecting the battery charger:

- Park the vehicle, turn the key switch to OFF and remove the key.
- Inspect the charging receptacle for dirt or debris. Clean if necessary.
- Inspect the charger cords for cracks or damage. Replace any damaged cords before use.

- Plug the charger into a receptacle on a dedicated circuit. Do not connect any other devices to the receptacle.
- Connect the charger to the vehicle.

## BATTERY CHARGING

The battery charger is designed to completely charge the battery set. If the batteries are severely deep cycled the charger will indicate a fault. The automatic charger determines the correct length of charge for the battery set and turns off when the batteries are charged. Always refer to the instructions supplied with the charger. See Appendix A for charger operating instructions.

### AC Voltage

The battery charger output is directly related to the input voltage. If the vehicle receives an incomplete charge in a normally adequate time period, low AC voltage can be the cause. Consult an electrician if necessary.

## BATTERY PROLONGED STORAGE

**Improper storage may damage, destroy or cause permanent loss of battery capacity. Do not exceed storage time or temperature limits. Batteries must be charged to the correct level before storage. Storing fully depleted batteries will make them permanently unusable.**

### Storage Preparation

The optimum storage temperature range is between 65°F and 82°F (18°C and 28°C)

- Charge the battery module based on climate during storage period.
  - In cold climates, fully charge the battery module. Make sure that the charging operation is complete and there are no faults displayed on the charger. The green light on the charger should be on indicating the charge cycle is complete.
  - In hot climates, store the vehicle with a 30% to 50% charge of battery pack capacity.
- Turn the key to the OFF position and remove it from the key switch.
- Check the run - tow switch under the seat, make sure it is set in the RUN position.
- Turn off all accessories.

The storage time for properly charged Lithium-Ion batteries supplied with this vehicle varies based on the ambient temperature.

Temperature	Length of Storage Time
-22°F to -4°F (-30°C to -20°C)	One month at 30%-50% battery charge, all accessories turned off.
-4°F to 113°F (-20°C to 45°C)	Six months at 100% battery charge, all accessories turned off.
113°F to 140°F (45°C to 60°C)	One month at 100% charge, all accessories turned off.

## BATTERY FAULT DIAGNOSIS

Refer to the charger instructions in Appendix A.

# **MAINTENANCE**

## **TRANSPORTING THE VEHICLE**

### **⚠ WARNING**

**Do not ride or allow other people on a vehicle being transported on a trailer or being towed with another vehicle.**

### **Towing the Vehicle**

### **⚠ WARNING**

**Do not try to tow the vehicle with ropes, chains or any device different from a tow bar approved by the manufacturer. Use an E-Z-GO golf car with an approved tow bar system to tow the vehicle.**

**Do not tow the vehicle on highways.**

**Do not tow the vehicle at speeds more than 12 mph (19 kph).**

**Do not tow more than three vehicles at one time.**

1. Connect the vehicle to the tow bar.
2. Place the direction selector in neutral (N).

### **Hauling the Vehicle**

### **⚠ WARNING**

**Loose cargo or vehicle components can fly off when the vehicle is being transported. Secure or remove all cargo. Inspect the vehicle for loose components prior to transport.**

**Do not allow any people on a vehicle being transported on a trailer.**

**Remove the windshield before you transport a vehicle on a trailer.**

**Maximum speed with canopy top installed is 50 mph (80 kph).**

- If the vehicle is being hauled on a trailer or truck at highway speeds, the canopy top must be removed.
  - If the vehicle is being hauled on a trailer or truck below highway speeds, check that canopy top hardware is tight and there are no cracks in the canopy top at the mounting points.
  - The rated capacity of the hauling trailer or truck must be more than the weight of the vehicle and load plus 1000 lbs. (454 kg). See GENERAL SPECIFICATIONS for the weight of the vehicle.
1. Drive the vehicle onto the trailer or truck.
  2. Set the park brake.
  3. Turn the key to the OFF position. To prevent loss of the key, remove it from the ignition switch.
  4. Make sure the seat(s) are secured.
  5. Secure the vehicle to the trailer or truck with tie downs, straps or ropes.

## ***VEHICLE SPECIFICATIONS***

# SPECIFICATIONS

## VEHICLE SPECIFICATIONS

Electric TXT ELiTE Freedom Personal Golf Car model year 2017

Item	Specification
Maximum Weight Capacity (includes weight of operator, passenger, cargo, accessories)	800 lb (363 kg)
Seating Capacity	2 person
Weight (No Batteries)	655 lb. (297 kg) without batteries
Curb Weight	755lb. (342 kg) four Lithium-Ion modules
Outside Clearance Circle	19 ft. (5.8 m)
Speed (Level Ground)	14.5-19.5 mph (23.3-31.4 kph)
Towing Capacity	3 ELiTE Golf Cars with Approved Permanent Tow Bar
Overall Length	93 in (236 cm)
Overall Width	47 in (119 cm)
Overall Height (no canopy)	47 in (119 cm)
Overall Height (with canopy)	68.5 in (174 cm)
Wheelbase	66.5 in (169 cm)
Track Width (front)	34.5 in (88 cm)
Track Width (rear)	38.5 in (98 cm)
Ground Clearance at Differential	4 in (10 cm)
Power Source	48 Volts DC
Motor Type	Shunt Wound
Battery Quantity and Type	Two, 48 Volt Li-Ion Modules (Standard Configuration)
Electrical System	48 Volt
Horsepower (kW)	3.1 hp (2.3 kW) Continuous
Key or Pedal Start	Pedal Start
Speed Controller	250 Amp Solid State Controller
Drive Train	Motor Shaft Direct Drive
Trans-axle	Differential with helical gears
Gear Selection	Body mounted Forward-Neutral-Reverse
Rear Axle Ratio	12.44:1
Steering	Self-compensating rack and pinion
Front Suspension	Leaf springs with hydraulic shock absorbers
Rear Suspension	Leaf springs with hydraulic shock absorbers
Service Brake	Rear wheel mechanical self-adjusting drum
Parking Brake	Self-compensating, single point engagement
Front Tires	18 x 8.50 - 8 (4 Ply Rated) Tires
Rear Tires	18 x 8.50 - 8 (4 Ply Rated) Tires
Frame	Welded steel. DuraShield™ powder coat
Body and Finish	Injection molded TPO
<b>CE Noise, Vibration and Harshness</b>	
Noise	Sound pressure; continued A-weighted equal to or less than 70 db (A)
Vibration, WBV	Highest value of weighted acceleration less than 2.5 m/s <sup>2</sup>
Vibration, HAV	Highest value of weighted acceleration less than 2.5 m/s <sup>2</sup>
	The uncertainty of measurement is 0.2 m/s <sup>2</sup>















# **APPENDIX A**

## **BATTERY CHARGER USER'S GUIDE**



## 1 kW Industrial Battery Charger

### QuiQ Charger - E-Z-GO Product Manual

This manual contains important safety and operating instructions for versions of the Delta-Q QuiQ (Model nos. 913-4830-E3/-E3B/-E5 /-E5B) installed on E-Z-GO brand vehicles. Please read this information before using your QuiQ Charger. For manufacturer contact information and technical support resources, please visit [delta-q.com/support](http://delta-q.com/support)



**SAVE THESE IMPORTANT SAFETY INSTRUCTIONS - This manual contains important safety and operating instructions – read before using charger.**

**INFORMATIONS IMPORTANTES DE SÉCURITÉ Ce manuel contient des instructions importantes concernant la sécurité et le fonctionnement.**



#### Warning

Charge only 48 Volt Lithium-Ion type batteries activated by Samsung SDI. Other types of batteries may burst causing personal injury and damage. Never charge a frozen battery. Study the battery manufacturer's specific precautions.



#### Attention

Recharger uniquement les batteries de type Lithium-Ion 48V activées par Samsung SDI. Autres types de batteries pourraient exploser causant des blessures corporelles et des dommages. Ne jamais charger une batterie gelée. Prendre connaissance des mesures de précaution spécifiées par le fabricant de la batterie.



#### Danger

Risk of electric shock. Connect charger power cord to an outlet that has been properly installed and grounded in accordance with all local codes and ordinances. A grounded outlet is required to reduce risk of electric shock – do not use ground adapters or modify plug. Do not touch uninsulated portions of output connector or uninsulated battery terminals. Disconnect the charger from either the AC supply or from the golf cart, before making or breaking the connections to the battery. Do not open or disassemble charger. Do not operate this charger if the AC supply cord is damaged or if the charger has received a sharp blow, been dropped, or is damaged in any way – refer all repair work to the manufacturer, or qualified personnel. This charger is not intended for use by persons (including children) with reduced physical, sensory or mental capabilities, or lack of experience and knowledge on electrical systems and battery charging, unless they have been given supervision or instruction concerning use of the charger by a person responsible for their safety. Children should be supervised to ensure that they do not play with the charger.



#### Danger

Risque de décharge électrique. Ne pas toucher les parties non isolées du connecteur de sortie ou les bornes non isolées de la batterie. Toujours connecter le chargeur à une prise de courant mise à la terre. Déconnectez la source AC avant de faire ou défaire les connexions à la batterie en chargement. Ne pas utiliser le chargeur si le cordon d'alimentation AC est endommagé ou si le chargeur est abîmé suite à une chute ou autre incident. Ne pas ouvrir ni désassembler le chargeur – référer toute réparation aux personnes qualifiées. Cet appareil n'est pas destiné à un usage par des personnes (dont les enfants) avec des facultés motrices, sensorielles ou mentales réduites, ou ayant une expérience et des connaissances insuffisantes, à moins qu'elles sont sous la supervision ou reçoivent les instructions sur l'utilisation de l'appareil d'un répondant garant de leur sécurité. Les enfants devraient être surveillés afin qu'il ne jouent en aucun temps avec l'appareil.

### Maintenance Instructions

1. Do not expose charger to high pressure water spray when cleaning vehicle.
2. The enclosure of the charger meets IP66, making it dust-tight and protected against powerful water jets. The AC connection is rated to IP20, which is not protected against water. Protect the AC connection if used in wet or dusty environments.
3. If the detachable input power supply cord set is damaged, replace with a cord that is appropriate for your region:
  - ✦ This charger is provided with a cord set for connection to outlets operating at nominal 120 Volts (or 240 Volts as appropriate). If the input plug does not fit the power outlet, contact Delta-Q Technologies for the proper cord set terminating in an attachment plug of the proper configuration for the power outlet.
  - ✦ North America: UL or CSA listed / approved detachable cord, 3 conductor, 16AWG minimum and rated SJT; terminated in a grounding type IEC 60320 C14 plug rated 250V, 13A minimum
  - ✦ For all other regions: Safety approved detachable cord, 3 conductor, 1.5mm<sup>2</sup> minimum, rated appropriately for industrial use. The cord set must be terminated on one end with a grounding type input connector appropriate for use in the country of destination and, on the other end, an output grounding type IEC 60320 C14 plug.

© 2016 Delta-Q Technologies Corp. All rights reserved.  
(PN: 710-0219 Rev 2 Date: 01/12/2017)



## Operating Instructions

**CAUTION:** Charger enclosure may be hot during charging. Use hand protection if handling the charger while charging.

- + Extension cords must be 3-wire cord no longer than 30m(100') at 10AWG or 7.5m(25') at 16AWG per UL guidelines.
- + Only connect **ONE** QuiQ charger to a single 15A circuit or the circuit may become overloaded.

**Ammeter**

Displays scale of output current

- + If only ammeter and AC Indicator LEDs are lit: Less than 80% state of charge
- + If flashing: Output has been reduced due to high internal charger temperature.

**Charger 10-LED Display**

**Charge Indicator (Orange Light)**

- + If solid: Greater than 80% state of charge
- + If off: Less than 80% state of charge or pre-charge

**Charge Completion Indicator (Green Light)**

- + If solid: Charging is complete

**AC Indicator (Orange Light)**

- + If solid: AC power is present.
- + If flashing: Low AC voltage. Check electrical source and cord length.

**Fault Indicator (Red Light)**

- + Charger error. Refer to troubleshooting information below.



### Receptacle Display

LED	Indication
Solid	Charge complete
Long flash	Greater than 80% state of charge
Short flash	Less than 80% state of charge
Off	See charger for indications.

## Troubleshooting Instructions

If a fault occurs, count the number of red flashes between pauses and refer to the table below.

Flashes	Cause	Solution
⏸️ 🔴 🔴 🔴 ⏸️	Charger unable to apply wake-up pulse	Refer cart to service department
⏸️ 🔴 🔴 🔴 🔴 ⏸️	Charge timeout	Possible BMS error - refer cart to service department
⏸️ 🔴 🔴 🔴 🔴 🔴 ⏸️	BMS fault	Refer cart to service department
⏸️ 🔴 🔴 🔴 🔴 🔴 🔴 🔴 ⏸️	Charger shutdown due to high internal temperature.	Ensure sufficient cooling airflow. Reset the charger by interrupting AC power for 15+ seconds.
⏸️ 🔴 🔴 🔴 🔴 🔴 🔴 🔴 🔴 ⏸️	Internal charger fault	Reset the charger by interrupting AC power for 15+ seconds. Return to service department if fault persists.

Note: This is a Class A product. In a domestic environment this product may cause radio interference, in which case the user may be required to take adequate measures.

**APPENDIX A**

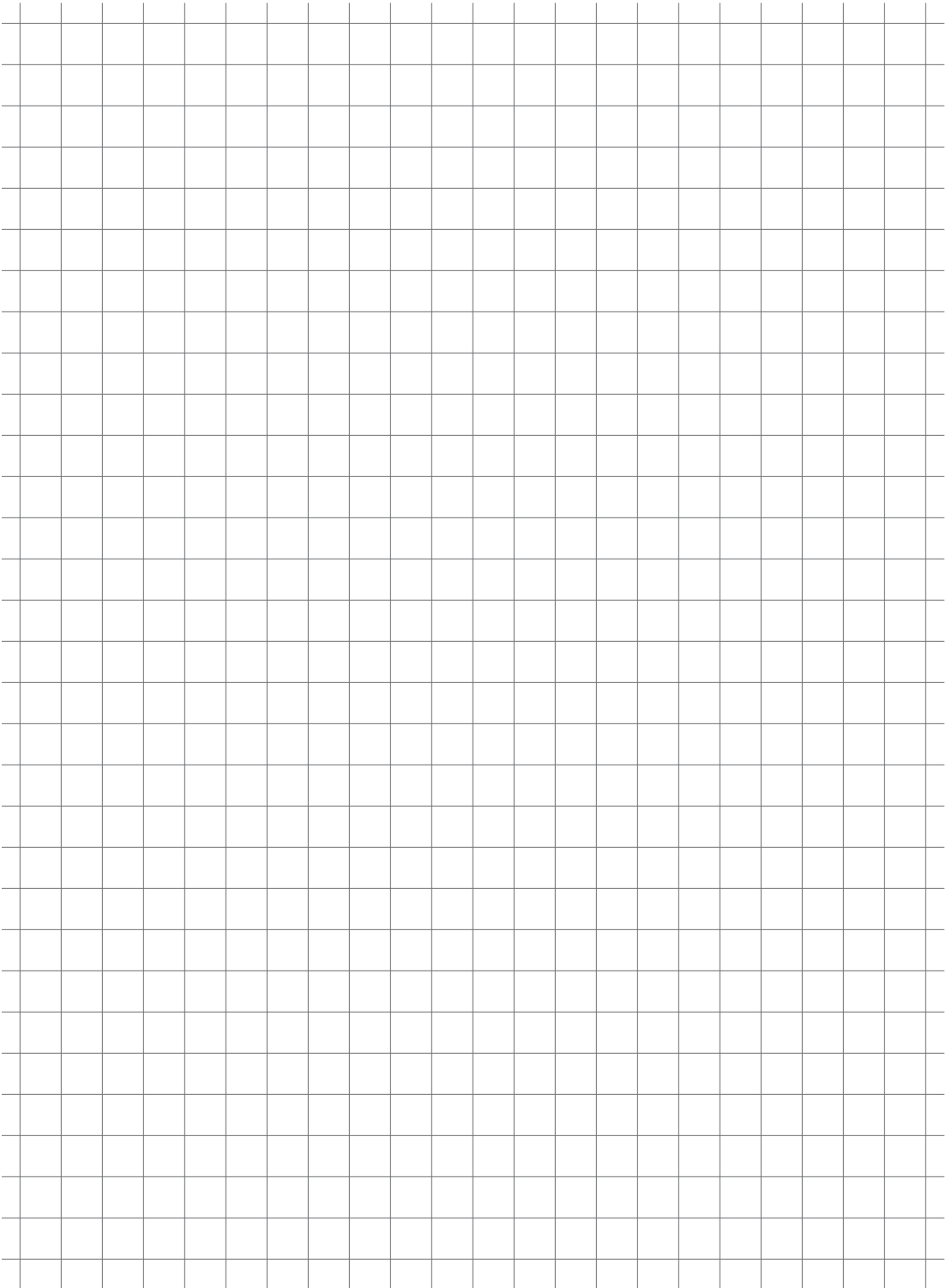

A large grid of empty cells for data entry, consisting of 20 columns and 25 rows.

# **APPENDIX B**

## **DECLARATION OF CONFORMITY**





**APPENDIX B**

A large grid of 20 columns and 30 rows, intended for data entry or calculations. The grid is composed of thin, light gray lines forming a uniform pattern of small squares.

Normal use, age and wear on vehicle components can affect the safe operation and reliability of the vehicle. The recommended inspection and maintenance procedures are crucial for safety, performance, reliability and maximum longevity of your vehicle.

A damaged vehicle, or a vehicle that is not functioning properly is dangerous and must not be operated until repairs are made.

**NOTICE: Read the following operational warnings before driving the vehicle:**

Before you leave the vehicle, turn the key to the OFF position and remove the key from the vehicle to prevent unauthorized use.

**WARNING**

**Drive the vehicle at appropriate speeds for the terrain and conditions. Be aware of environmental conditions that change the terrain and your ability to control the vehicle.**

**Do not drive on excessively steep hills. Evaluate the terrain before descending a hill. Drive slowly and deliberately. Use the brake to limit speed and maintain control. Sudden braking or turning can cause loss of vehicle control. Drive straight down the hill; do not drive across the hill.**

**Operate in approved areas.**

**Keep feet, legs, hands and arms inside vehicle at all times.**

**Avoid driving on terrain that is too rough for your vehicle's capabilities and your driving skills.**

**Before you drive in the reverse direction, make sure the area behind the vehicle is clear. Accelerate slowly and avoid making sharp turns.**

**Make sure the direction selector is in the correct position before you press the accelerator pedal.**

**Decrease speed before and during turns.**

**Bring the vehicle to a complete stop before you move the direction selector.**

**See GENERAL SPECIFICATIONS for the vehicle load and seat capacity.**

**NOTICE: Read the following maintenance information and warnings before servicing or repairing the vehicle:**

Follow the procedures and comply with the safety information in this manual while performing vehicle service or maintenance.

Use the tools shown in the tool list and wear the specified safety equipment when performing vehicle service or maintenance.

**WARNING**

**Remove all jewelry before you service the vehicle.**

**Do not allow loose clothing or hair to contact the moving parts.**

**Do not touch hot objects.**

**The drive wheels must be lifted and supported on jack stands before you perform any service to the powertrain while the motor is in operation.**



**When you service the vehicle, always wear eye protection. Be careful when working around batteries, using solvents or compressed air.**

**Use insulated wrenches to decrease the risk of a short-circuit if a wrench contacts the battery terminals. A short-circuit in a battery can cause an explosion.**

**To prevent the risk of battery explosion, keep all flammable materials, open flames or sparks away from the batteries.**

**Maintain constant awareness that some components are heavy, spring loaded, corrosive, explosive, can cause high amperage or get extremely hot. Battery acid and hydrogen gas can cause bodily injury. Keep your hands, face, feet and body away from any area that can expose them to injury if an unexpected situation occurs.**



A Textron Company

***Textron Specialized Vehicles, Inc.***

1451 Marvin Griffin Road  
Augusta, Georgia 30906 - 3852  
USA

**CONTACT INFORMATION**

**North America:**

**Technical Assistance & Warranty** Phone: 1-800-774-3946, FAX: 1-800-448-8124

**Service Parts** Phone: 1-888-GET-E-Z-GO (1-888-438-3946), FAX: 1-800-752-6175

**International:**

**Phone: 001-706-798-4311, FAX: 001-706-771-4609**

Parts Manuals and Repair Manuals are available from a local Distributor, an authorized Branch, Genuine E-Z-GO Parts & Accessories Department or at [www.shopezgo.com](http://www.shopezgo.com).